

TECHNICAL MANUAL  
 OPERATOR, UNIT, AND  
 DIRECT SUPPORT MAINTENANCE MANUAL  
 (INCLUDING REPAIR PARTS AND SPECIAL TOOLS LIST)

FOR  
 POWER DISTRIBUTION  
 PANEL, 100KW  
 MODEL PEU-155/E  
 P/N M29183/19  
 NSN 6110-01-248-6671

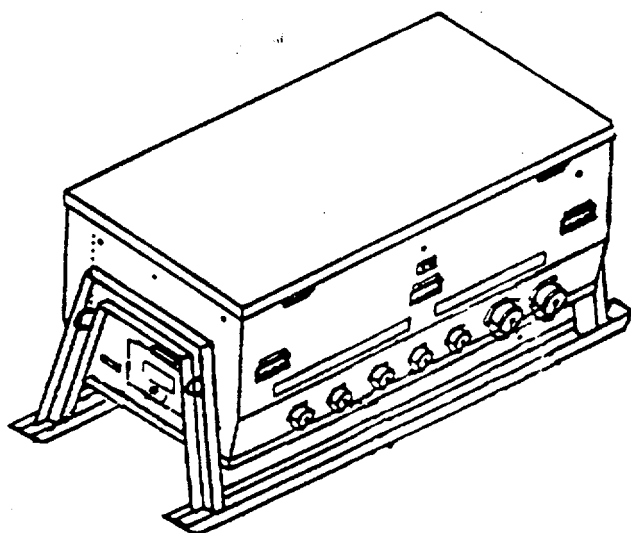

**INTRODUCTION** 1-1

**OPERATING INSTRUCTIONS** 2-1

**OPERATING MAINTENANCE INSTRUCTIONS** 3-1

**UNIT MAINTENANCE INSTRUCTIONS** 4-1

**DIRECT SUPPORT MAINTENANCE INSTRUCTIONS** 5-1

**REFERENCES** A-1

**MAINTENANCE ALLOCATION CHART** B-1

**COMPONENTS OF END ITEM AND BASIC ISSUE ITEMS LIST** C-1

**ADDITIONAL AUTHORIZATION** D-1

**EXPENDABLE AND DURABLE ITEMS LIST** E-1

**OPERATOR, UNIT, AND DIRECT SUPPORT MAINTENANCE REPAIR PARTS AND SPECIAL TOOL LIST** F-1

**ILLUSTRATED LIST OF MANUFACTURED ITEMS** G-1

**TORQUE LIMITS** H-1

DISTRIBUTION STATEMENT A: Approved for public release: distribution is unlimited.

**WARNINGS**

HIGH VOLTAGE  
is used in the operation of this equipment.

Never work on electrical equipment unless there is another person nearby who is familiar with the operation and hazards of the equipment and who is competent in administering first aid. When the technician is aided by operators, he must warn them about dangerous areas. The power supply to the equipment must be shut off before beginning work on the equipment. The power source must be grounded at all times when equipment is in use or being worked on. Be careful not to contact high voltage connections of 120/208 Vac when installing or operating this equipment. Death or serious injury may result.

**WARNINGS**

High Voltage is present in this system. The power distribution panel supports equipment using 120/208 Vac. Do not rely on the color of the wire insulation for phase color-coding. The insulation on wires inside the cable jacket may vary, depending on supplier. Wires will be marked with colored tape to designate the phases. Perform a continuity test to verify correct phase designation in accordance with the colored tape. Death or serious injury may result.

**WARNINGS**

HEAVY COMPONENTS

Components of this system are heavy and may be awkward to handle. Use correct lifting procedures and/or assistance from other personnel to avoid personal injury.

**WARNINGS**

FIRST AID

For artificial respiration, refer to FM 21 -1 1.

a/(b blank)

TECHNICAL MANUAL

NO. 9-6150-228-13&P

HEADQUARTERS  
DEPARTMENT OF THE ARMY  
WASHINGTON, D.C, 28 FEBRUARY 1996

**OPERATOR, UNIT, AND  
DIRECT SUPPORT,  
MAINTENANCE MANUAL  
(INCLUDING REPAIR PARTS  
AND SPECIAL TOOLS LIST)  
FOR**

**POWER DISTRIBUTION  
PANEL, 100 KW**

**MODEL PEU-155/E  
P/N M29183/19  
NSN 6110-01-2486671**

**REPORTING ERRORS AND RECOMMENDING IMPROVEMENTS**

You can help improve this manual. If you find any mistakes, or if you know of a way to improve these procedures, please let us know. Mail your letter or DA Form 2028 (Recommended Changes to Publications and Blank Forms), or DA Form 2028-2 located in the back of this manual directly to: Commander, US Army Aviation and Troop Command, ATTN: AMSAT-I-MP, 4300 Goodfellow Blvd., St. Louis, MO 63120-1798. You may also submit your recommended changes by E-mail directly to <mpmt/oavma28@st-louis-emh7.army.mil>. A reply will be furnished directly to you. Instructions for sending an electronic 2028 may be found at the back of this manual immediately preceding the hard copy 2028.

**DISTRIBUTION STATEMENT A.** Approved for public release; distribution is unlimited.

**TABLE OF CONTENTS**

		<b>Page</b>
	HOW TO USE THIS MANUAL.....	vi
CHAPTER 1	<b>INTRODUCTION</b>	
Section I	General Information .....	1-1
Section II	Equipment Description .....	1-3
Section III	Technical Principles of Operation.....	1-6
CHAPTER 2	<b>OPERATING INSTRUCTIONS</b>	
Section I	Description and Use of Operator's Controls and Indicators .....	2-1
Section II	Operator Preventive Maintenance Checks and Services (PMCS).....	2-4
Section III	Operation Under Usual Conditions .....	2-7
Section IV	Operation Under Unusual Conditions .....	2-17

**TABLE OF CONTENTS (Continued)**

	Page
CHAPTER 3	<b>OPERATOR MAINTENANCE INSTRUCTIONS</b>
Section I	Lubrication Instructions. .... 3-1
Section II	Troubleshooting Procedures..... 3-1
Section III	Maintenance Procedures..... 3-3
CHAPTER 4	<b>UNIT MAINTENANCE INSTRUCTIONS</b>
Section I	Repair Parts; Special Tools; Test, Measurement, and Diagnostic Equipment (TMDE); and Support Equipment ..... 4-1
Section II	Service Upon Receipt ..... 4-1
Section III	Unit Preventive Maintenance Checks and Services (PMCS) ..... 4-2
Section IV	Unit Troubleshooting ..... 4-4
Section V	Maintenance Procedures..... 4-17
Section VI	Preparation for Storage or Shipment ..... 4-42
CHAPTER 5	<b>DIRECT SUPPORT MAINTENANCE INSTRUCTIONS</b>
Section I	Repair Parts; Special Tools; Test, Measurement, and Diagnostic Equipment (TMDE); and Support Equipment . 5-1
Section II	Direct Support Troubleshooting ..... 5-1
Section III	Maintenance Procedures..... 5-2
APPENDIX A	<b>REFERENCES</b> ..... A-1
APPENDIX B	<b>MAINTENANCE ALLOCATION CHART</b> ..... B-1
APPENDIX C	<b>COMPONENTS OF END ITEM (COEI) AND BASIC ISSUE ITEMS (BII) LISTS</b> ..... C-1
APPENDIX D	<b>ADDITIONAL AUTHORIZATION LIST (AAL)</b> ..... D-1
APPENDIX E	<b>EXPENDABLE AND DURABLE ITEMS LIST</b> ..... E-1

**TABLE OF CONTENTS (Continued)**

	<b>Page</b>	<b>Figure</b>
APPENDIX F	OPERATOR, UNIT, AND DIRECT SUPPORT MAINTENANCE REPAIR PARTS AND SPECIAL TOOLS LIST (RPSTL)	
Section I	F-1	
Section II	F-8	
Group 00	Power Distribution Panel 00 KW	
	F-9	F-1
Group 01	Top Cover Assembly	
	F-11	F-2
Group 02	Panel Assembly, Deadfront	
	F-13	F-3
Group 03	Subpanel, Indicator Light Assembly, Indicator Bulb	
Group 04	Circuit Breakers	
	F-17	F-4
	Subpanel, Indicator Light Assembly, Indicator Bulb and Circuit Breakers	
Group 05	F-21	F-5
Group 06	F-25	F-6
Group 07	Fuse Holder	
	F-25	F-6
Group 08	Solenoid, Interlock	
	F-27	F-7
Group 09	Leads, Electrical	
	F-29	F-8
Group 10	Connectors, MS	
	F-31	F-9
Group 11	Cabinet Assembly	
	F-34	F-10
Group 12	Cable Assemblies	
	F-37	F-11
	F-39	F-12
Group 13	Bulk	
Section III	Special Tools List (Not Applicable)	
Section IV	Cross-Reference Indexes	
	F-42	
	F-44	
	F-50	
APPENDIX G	ILLUSTRATED LIST OF MANUFACTURED ITEMS	
	G-1	
APPENDIX H	TORQUE LIMITS	
	H-1	
	Glossary-1	
	Index-1	

## LIST OF ILLUSTRATIONS

Figure	Title	Page
1-1	Power Distribution Panel .....	1-1
1-2	Power Distribution Panel Component Location .....	1-4
1-3	Power Distribution Panel Block Diagram .....	1-6
2-1	Power Distribution Panel Controls, Indicators, and Connectors .....	2-2
2-2	1 00-Amp/60-Armp Connectors.....	2-2
2-3	Terminal <b>B</b> locks .....	2-3
2-4	Power Connection Terminal .....	2-10
2-5	Decal and Instruction Plates Location .....	2-13
2-6	Power Distribution Panel Decal and Information Plates.....	2-14
4-1	Power Cable Wiring Diagrams .....	4-16
4-2	Top Cover Assembly .....	4-18
4-3	Top Cover Assembly. ....	4-20
4-4	Sub Panel .....	4-22
4-5	Indicator Light Assembly .....	4-24
4-6	Indicator Light Assembly .....	4-25
4-7	Circuit Breaker Test.....	4-26
4-8	Circuit Breaker Removal .....	4-28
4-9	Terminal Block Removal .....	4-31
4-10	Fuse/Fuse Holder Removal .....	4-33
4-11	Interlock Solenoid .....	4-35
4-13	MS Connectors.....	4-38
4-14	Internal Cable Assembly .....	4-40
4-15	External Cable Assembly .....	4-41
5-1	Top Cover Assembly .....	5-2
5-2	Deadfront Panel Assembly .....	5-5
5-3	400 Amp Circuit Breaker Assembly.....	5-9
5-5	Interior Panel Board Assembly.....	5-10
5-6	Sub Chassis Bus Bar .....	5-12
5-7	Sub Chassis Bus Bar .....	5-13
5-8	Sub Chassis Bus Bar .....	5-16
5-9	Electrical Leads .....	5-19
5-10	MS Connector.....	5-21
5-11	Cabinet Assembly.....	5-23
F-1	Power Distribution Panel.....	F-8
F-2	Top Cover and Restraining Cable.....	F-10
F-3	Deadfront Panel Assembly .....	F-12
F-4	Subpanel, Indicator Light Assy, Indicator Bulb, and Circuit Breakers.....	F-14
F-5	Internal Panel Board Assembly.....	F-18
F-6	Terminal Blocks, Fuse Holder, and Fuse .....	F-24
F-7	Solenoid Interlock .....	F-26
F-8	Electrical Leads .....	F-28
F-9	Connectors .....	F-30

**LIST OF ILLUSTRATIONS (CONTINUED)**

<b>Figure</b>	<b>Title</b>	<b>Page</b>
F-10	Cabinet Assembly .....	F-32
F-11	60-Amp Power Cable Assembly .....	F-36
F-12	1 00-Amp Power Cable Assembly .....	F-38
G-1	60-Amp, 1 00-Ft. (30.5m) Power Cable .....	G-4
G-2	1 00-Amp, 50-Ft. (1 5.2m) Power Cable .....	G-7
G-3	Power Input Cable Assembly .....	G-10
FO-1	Power Distribution Panel Schematic Diagram .....	FP-1

**LIST OF TABLES**

<b>Table</b>	<b>Title</b>	<b>Page</b>
1-1	Power Distribution Panel Data .....	1-5
2-1	Operator Preventive Maintenance Checks and Services for Model PEU-1 55/E ..	2-1
2-2	Typical User Requirements.....	2-8
3-1	Operator Troubleshooting.....	3-2
4-1	Service Upon Receipt Checklist.....	4-1
4-2	Unit Preventive Maintenance Checks and Service.....	4-3
4-3	Unit Troubleshooting.....	4-6
4-4	Power Distribution Panel Continuity Checks.....	4-9
4-5	Power Cable Continuity Checks.....	4-12
4-6	Power Distribution Panel Wire List.....	4-13
G-1	Crimp Tool Selection Chart.....	G-1
G-2	Crimp Tools.....	G-2
H-1	Self-Locking Nut Breakaway Torque Values .....	H-2

## HOW TO USE THIS MANUAL

This manual is designed to help install, operate, and maintain the power distribution panel. Listed below are some of the special features of this manual which will help to locate and use the information needed.

A front cover index gives a quick reference to chapters and sections that will be used often.

The appendixes are located at the end of the manual. They contain a reference guide to other manuals, a maintenance allocation chart, a list of components of end items and basic issue items, a list of additional authorized items, a list of expendable supplies and materials, a repair parts and special tools list, a manufactured items list, and torque values.

Each new maintenance task begins on a new page. Often a complete task is described on only two pages.

The maintenance tasks tell what has to be done to the system before a task is started, and what must be done to return the system to operating condition after the task is finished.

The manual is divided into chapters containing operator, unit, and direct support maintenance procedures. These procedures tell a number of things such as:

What is needed to do the job.

If any assistance is needed.

Safety precautions.

In addition to the text, there are illustrations to aid in connecting, operating, and maintaining the power distribution panel. The illustrations are keyed to the text and show how to remove the part, repair the part, and install the part. Cleaning and inspection procedures are also included when required.

Become familiar with the entire maintenance procedure before beginning a maintenance task.

Read warnings and cautions before performing any procedures.



CHAPTER 1

INTRODUCTION

SECTION I. GENERAL INFORMATION

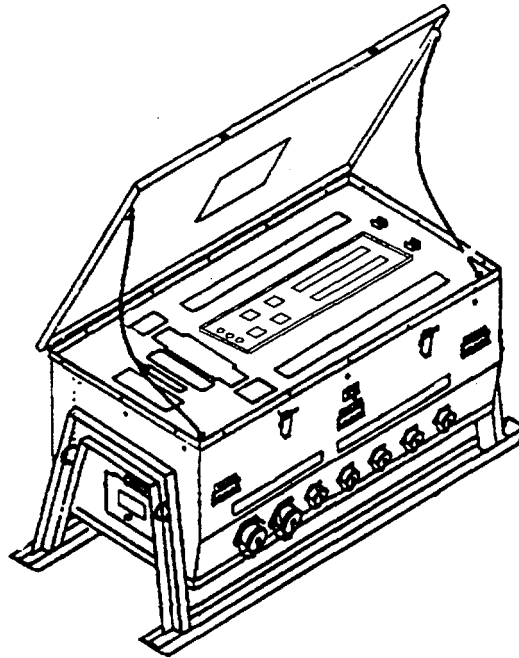

FRONT VIEW

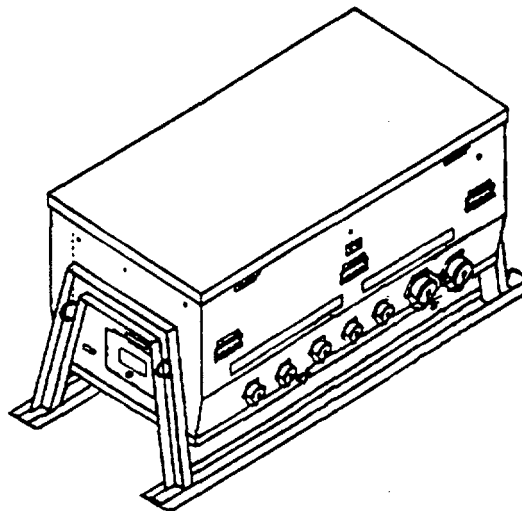

REAR VIEW

Figure 1-1. Power Distribution Panel.

**1.1 SCOPE.**

1.1.1 Type of Manual. Operator, Unit, and Direct Support Maintenance Manual (including Repair Parts and Special Tools List).

**1.1.2. Model Number and Equipment Name.**

1.1.2.1 Model number for this end item is PEU-155/E.

1.1.2.2 Part number for this end item is M29183/19.

1.1.2.3 Complete nomenclature for this end item is Power Distribution Panel.

1.1.3 Purpose of Equipment. The purpose of this equipment is to provide the user a means of supplying power to several points, using a single power supply or two power supplies when continuous operation is required.

**1.2 MAINTENANCE FORMS AND PROCEDURES.** Department of the Army forms and procedures used for equipment maintenance will be those prescribed by DA PAM 738-750, The Army Maintenance Management System(TAMMS).

**1.3 CORROSION PREVENTION AND CONTROL (CPC).**

1.3.1 Corrosion Prevention and Control (CPC)\_of Army materiel is a continuing concern. It is important that any corrosion problems with this item be reported so that the problem can be corrected and improvements can be made to prevent the problem in future items.

1.3.2 While corrosion is typically associated with rusting of metals, it can also include deterioration of other materials, such as rubber and plastic. Unusual cracking, softening, swelling, or breaking of these materials may be a corrosion problem.

1.3.3 If a corrosion problem is identified, it can be reported using Standard Form 368 (Product Quality Deficiency Report). Use of keywords such as corrosion, rust, deterioration, or cracking will ensure that the information is identified as a CPC problem. The form should, be submitted to the address specified in DA PAM 738-750.

**1.4 DESTRUCTION OF ARMY MATERIEL TO PREVENT ENEMY USE.** For general destruction procedures for this equipment refer to TM 750-244-2 and -3, Procedures for Destruction of Equipment to Prevent Enemy Use (US Army Mobility Equipment Command).

**1.5 REPORTING EQUIPMENT IMPROVEMENT RECOMMENDATIONS (EIR).** If your power distribution panel needs improvement, let us know. Send us an EIR. You, the user, are the only one who can tell us what you don't like about your equipment. Let us know why you don't like the design. Put it on an SF 368 (Product Quality Deficiency Report). Mail it to us at: Commander, US Army Aviation and Troop Command, 4300 Goodfellow Blvd., St Louis, MO 63120-1798, ATTN: AMSAT-I-MDO. We will send you a reply.

**1.6 QUALITY ASSURANCE/QUALITY CONTROL (QA/QC).** Quality Assurance/Quality Control Procedures used will be those enforced by the local Commanding Officer.

**1.7 LIST OF ABBREVIATIONS.** Abbreviation used in this manual are listed in the glossary at the end of this manual. Explanation of terms used in this manual are included in the glossary.

## SECTION II. EQUIPMENT CHARACTERISTICS, CAPABILITIES, AND FEATURES

### 1.8 EQUIPMENT CHARACTERISTICS, CAPABILITIES, AND FEATURES.

- 1.8.1 Self-contained.
- 1.8.2 Skid-mounted.
- 1.8.3 Highly portable.
- 1.8.4 All weather operational.
- 1.8.5 The power distribution panel interconnects electrical power between power generation equipment and power using equipment.
- 1.8.6 The power distribution panel consists of a single enclosure and a complement of electrical cables.
- 1.8.7 The power distribution panel provides convenience and flexibility by consolidating power sources.
- 1.8.8 The power distribution panel is designed for use in a battlefield environment and can be disassembled and reassembled quickly for rapid relocation.
- 1.8.9 The user's electrical equipment is protected by the circuit breakers in the power distribution panel.
- 1.8.10 The power distribution panel uses military standard class-L connectors.

### 1.9 LOCATION AND DESCRIPTION OF MAJOR COMPONENTS.

- 1.9.1 Typical System Placement. The placement of the power distribution panel (Figure 1 -1) in the field is dependent upon field conditions, tactical considerations, and unit needs.
- 1.9.2 Equipment Components (Figure 1-2).
  - 1.9.2.1 Interlock (400-amp circuit breaker) - Prevents both main circuit breakers from being dosed at the same time.
  - 1.9.2.2 Circuit breaker (400-amp) (2 ea) - Provides interconnect to the main bus bar.
  - 1.9.2.3 Phase indicator light (3 ea) - Indicates which load phase is being used.
  - 1.9.2.4 Circuit breaker (100-amp) (4 ea) - Provides power to 100-amp connectors.
  - 1.9.2.5 Circuit breaker (60-amp) (10 ea) - Provides power to 60-amp connectors.
  - 1.9.2.6 Terminal Board (2 ea) - TB1 and TB2, input power connection.
  - 1.9.2.7 Connector 60-amp (10 ea) - Provides hook-up for 60 amp power cables.
  - 1.9.2.8 Connector 100-amp (4 ea) - Provides hook-up for 100 amp power cables.
  - 1.9.2.9 Top cover - Provides access to circuit breakers and indicator lights.
  - 1.9.2.10 Access door (2 ea) - Provides access to terminal block assembly and fuse.

1.9.2.11 Ground lug - Frame ground.

1.9.2.12 Solenoid interlock (2 ea) - Locks access door when power is applied to the power distribution panel.

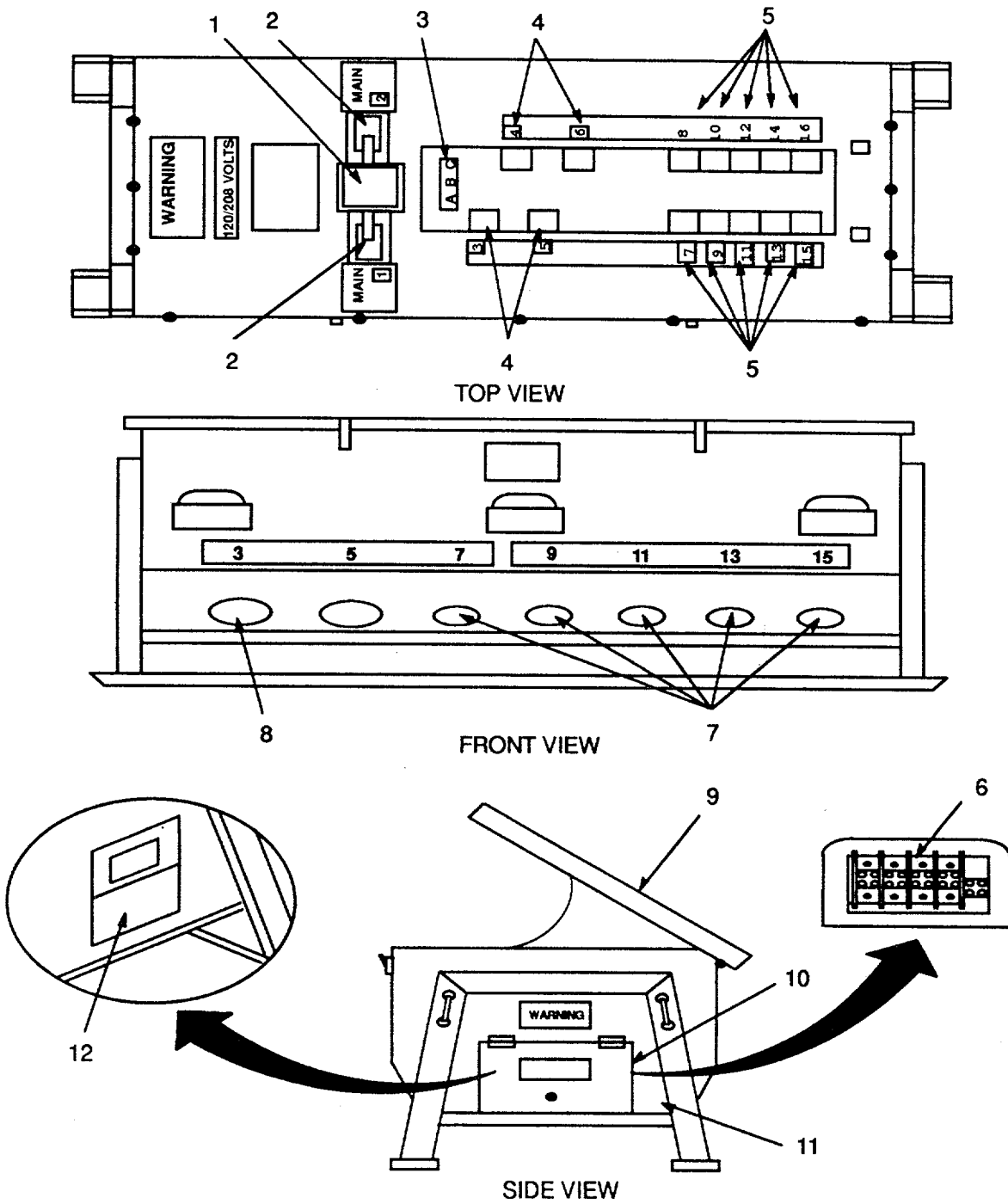

Figure 1-2. Power Distribution Panel Component Location.

**1.10 EQUIPMENT DATA.** Table 1 -1 lists equipment data for the power distribution panel.

*Table 1-1. Power Distribution Panel Data*

---

<b>WEIGHTS AND DIMENSIONS</b>	
Weight	450 lb (204.3 kg)
Length	75 in. (190.5 cm)
Width	33 in. (83.8 cm)
Height	32 in. (81.3 cm)
<b>PERFORMANCE</b>	
Frequency rating	60 Hz
Voltage rating	120/208 V
Number of phases	3
Maximum amperage/phase	400-amp
Maximum output load	144 kW
Input load terminals (per input TB)	2
Output connectors (quantity)	
100-amp/8-pinJ3-phase	4
60-amp/5-pin/3-phase	10
Circuit breakers (quantity)	
400-arnp/3-phase	2
100-amp/3-phase	4
60-amp/3-phase	10
Indicator lights (quantity)	3

---

SECTION III. TECHNICAL PRINCIPLES OF OPERATION

1.11 PRINCIPLES OF OPERATION (FIGURE 1-3).

1.11.1 Power is supplied to the power distribution panel by a pair of generators. Each generator is connected to the power distribution panel through a dedicated terminal bar.

1.11.2 The two terminal bars are each connected to the power distribution panel power buses through a 400-amp per phase circuit breaker. The purpose of having two generators, two sets of input terminals, and two main circuit breakers is to minimize power interruption to user's equipment. When both generators are running, the operator can switch the load from the one power unit to the other using the main circuit breakers. The slide bar assembly prevents both inputs from being connected to the bus bars at the same time. The slide bar also prevents the operator from inadvertently back powering an unused input.

1.11.3 The power from the power distribution panel is supplied to the branch circuits which feed the user's equipment. Ten 60-amp and four 100-amp power cables can be connected to the power distribution panel simultaneously. The maximum load at any one time, however, cannot exceed the 400-amp per phase capacity of the main circuit breaker. A dedicated circuit breaker protects each output connector repeated and its associated power cable from overloads.

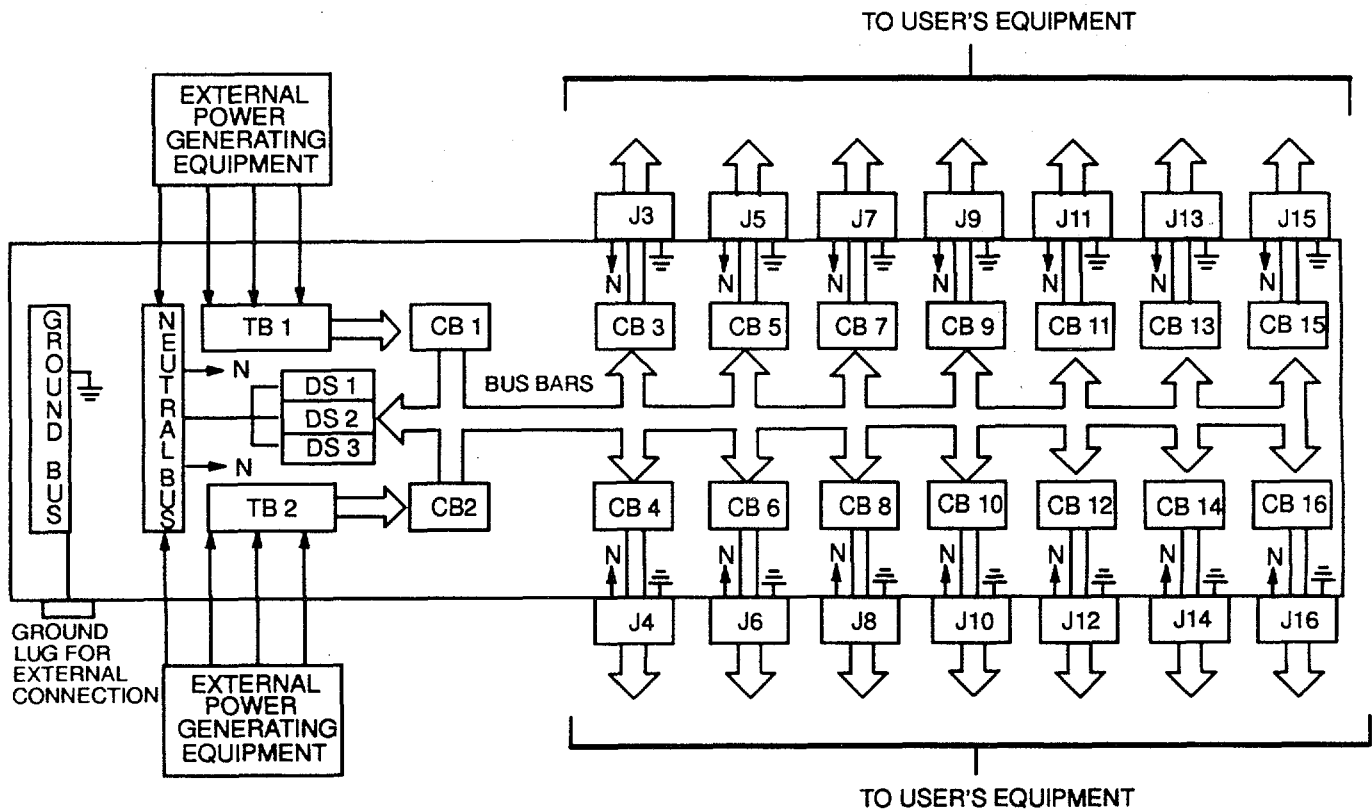

Figure 1-3. Power Distribution Panel Block Diagram.

## CHAPTER 2

## OPERATING INSTRUCTIONS

SECTION I. DESCRIPTION AND USE OF OPERATOR'S CONTROLS AND  
INDICATORS**2.1 POWER DISTRIBUTION PANEL CONTROLS, INDICATORS, AND CONNECTORS.**

2.1.1 Interlock. 400-Amp Circuit Breakers. The sliding bar assembly (1, Figure 2-1) is mounted to the top panel over the main circuit breakers CB1 and CB2. These two 3-phase circuit breakers are wired in series between the input load terminals on TB1 and TB2 and the power distribution panel bus bars. Either circuit breaker will prevent input to the power distribution panel from exceeding a total current of 400 amps per phase (144 KVA maximum load). The main circuit breakers enable the operator to select from two possible sources of input power when TB1 and TB2 are connected to separate generators. These circuit breakers also allow the operator to turn off power to all output circuit breakers. This bar functions as a manual safety interlock by physically preventing both main circuit breakers from being dosed simultaneously. When two sources of input are connected, there is no chance of power from both being applied to the bus bars at the same time. In addition, this interlock prevents input power from one set of load terminals from being applied to the remaining set of input terminals.

2.1.2 Phase Indicator lights (DS1, DS2, and DS3). These three indicators (2) are located on the top panel below CB1 and CB2 respectively. Indicator DS1 is wired between neutral and phase A bus bar. Indicator DS2 is wired between neutral and phase B bus bar. Indicator DS3 is wired between neutral and phase C bus bar. In this way, when power is available at the output side of either main circuit breakers, the associated indicator light(s) will glow green.

2.1.3 Circuit Breaker. 100-Amp. 3-Phase (CB3 through CB6). Each 3-phase circuit breaker (3) is in series between the bus bars and a 100-amp output connector. These circuit breakers prevent output power to the associated connector from exceeding a current of 100 amps per phase (36 kW maximum load). These circuit breakers also enable the operator to turn power to individual 100-amp load circuits off and on as required.

2.1.4 Circuit Breaker. 60-Amp. 3-Phase (CB7 through CB16). Each 3-phase circuit breaker (4) is in series between the bus bars and 60-amp output connector. These circuit breakers prevent output power to the associated connector from exceeding a current of 60 amps per phase (21.6 kW maximum load). These circuit breakers also enable the operator to turn power to individual 60-amp load circuits off and on as required.

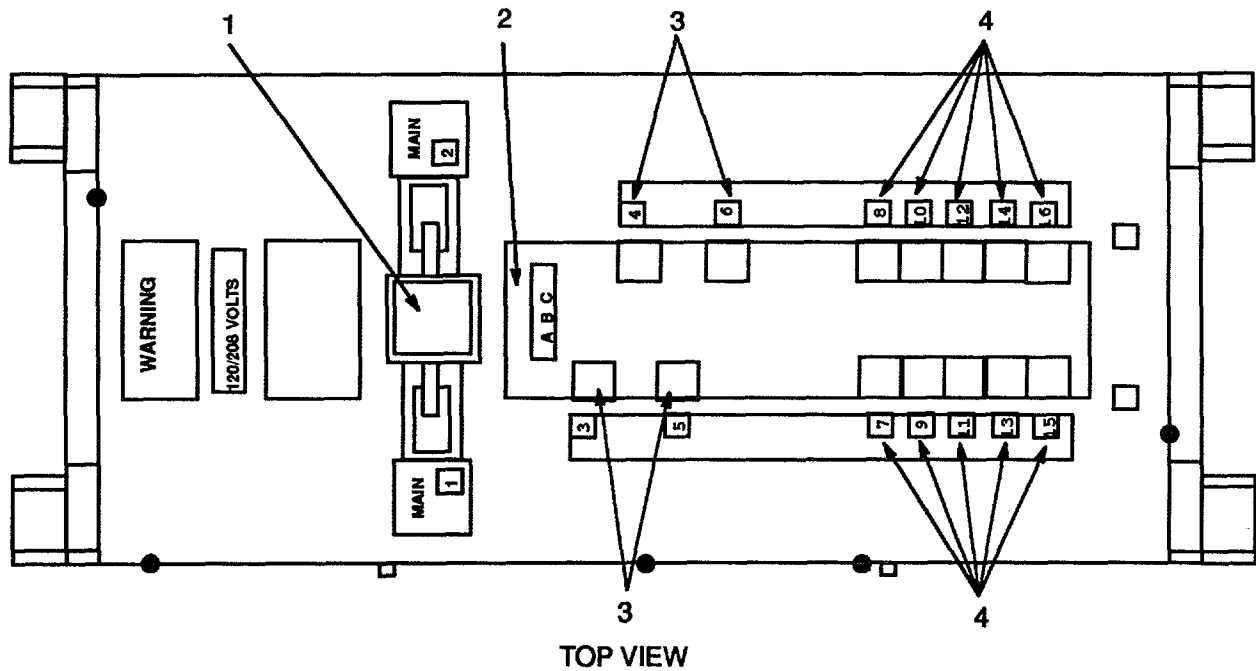

Figure 2-1. Power Distribution Panel Controls, Indicators, and Connectors.

2.1.5 Connectors. 100-Amp (J3 through J6). Each 8-pin connector (1, Figure 2-2) is connected to, and controlled by, a dedicated 100-amp circuit breaker. Together, they provide connection points for four 100-amp cables.

2.1.6 Connectors. 60-Amp (J7 through J16). Each 5-pin connector (2) is connected to, and controlled by a dedicated 60-amp circuit breaker. Together, they provide connection points for ten 60-amp cables.

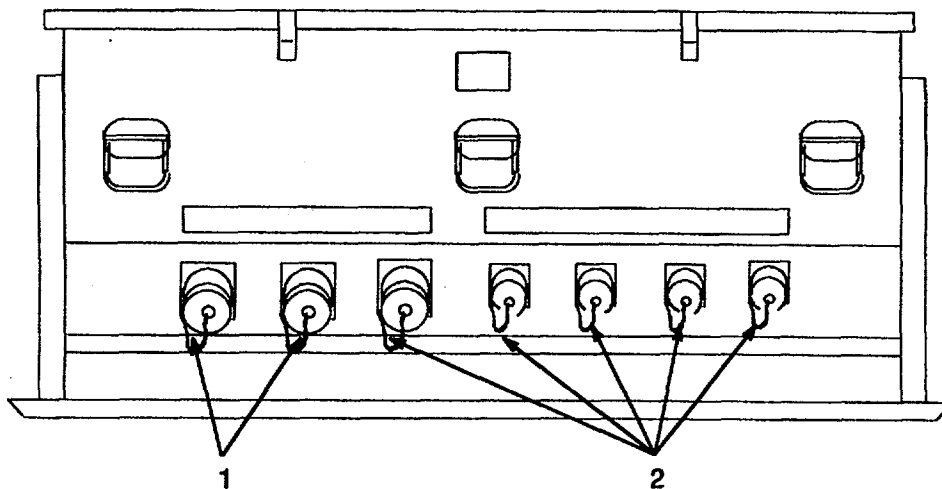
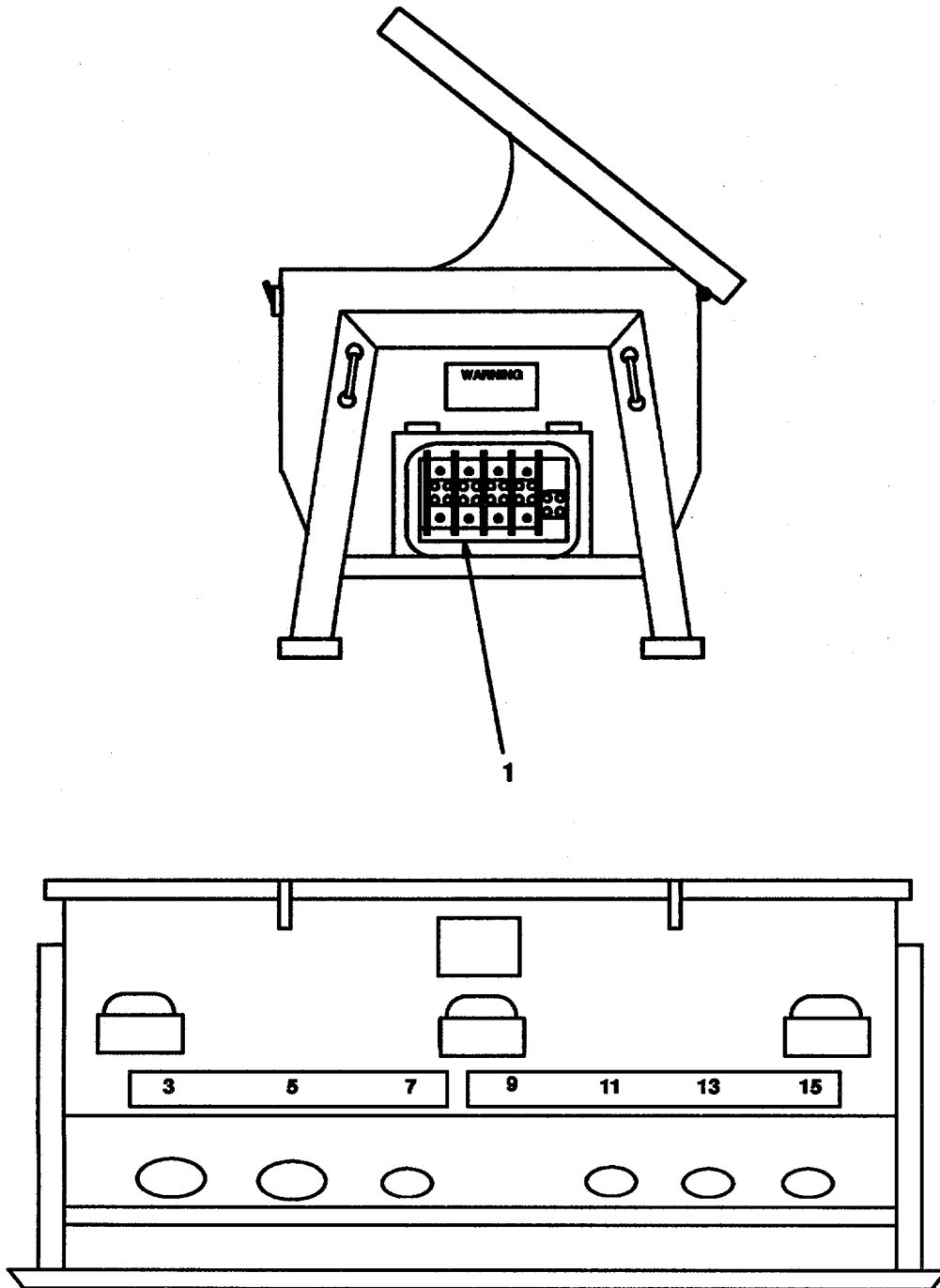

Figure 2-2. 100-Amp/60 Amp Connectors.



2.1.7 Terminal Blocks TB1 sand TB2). Each terminal block (1, Figure 2-3) provides a connection point from one input power source.



FRONT VIEW

Figure 2-3. Terminal Blocks.

## SECTION II. OPERATOR PREVENTIVE MAINTENANCE CHECKS AND SERVICES (PMCS)

### 2.2 INTRODUCTION.

2.2.1 To ensure that the power distribution panel is ready for operation at all times, it must be inspected systematically so defects may be discovered and corrected before they result in serious damage or failure. The necessary preventive maintenance checks and services (PMCS) that are to be performed by operator personnel are listed and described in Table 2-1.

2.2.2 Always observe the WARNINGS and CAUTIONS appearing in your PMCS table. WARNINGS and CAUTIONS appear before applicable procedures. You must observe these WARNINGS and CAUTIONS to prevent serious injury to yourself and others or prevent your equipment from being damaged.

2.2.3 When a check and service procedure is required for both weekly and before intervals, it is not necessary to do the procedure twice if the equipment is operated during the weekly period.

### 2.3 OPERATOR PMCS PROCEDURES.

2.3.1 General. To extend the service life and obtain maximum performance of the power distribution panel, the operator must adhere to the schedule and instructions in Table 2-1.

#### 2.3.2 Explanation of Table Columns.

2.3.2.1 Item Number Column. Numbers in this column are for reference. When completing DA Form 2404 (Equipment inspection and Maintenance Work Sheet), include the item number for the check service indicating a fault. Item numbers also appear in the order that you must do decks and services for the intervals listed.

2.3.2.2 Interval Column. This column tells you when you must do the procedure in the procedure column. BEFORE procedures must be done before you operator use the equipment for its intended mission. DURING procedures must be done during the time you are operating or using the equipment for its intended mission. AFTER procedures must be done immediately after you have operated or used the equipment.

2.3.2.3 Location, Item to Check/Service Column. This column provides the location and the item to be checked or serviced. The item location is underlined.

2.3.2.4 Procedure Column. This column gives the procedure you must do to check or service the item listed in the Check/Service column to know if the equipment is ready available for its intended mission or for operation. You must do the procedure at the time stated in the interval column.

2.3.2.5 Not Mission Capable If: Column. Information in this column tells you what faults will keep your equipment from being capable of performing its primary mission. If you make check and service procedures that show faults listed in this column, do not operate the equipment. Follow standard operating procedures for maintaining the equipment or reporting equipment failure.

#### NOTE

If the equipment must be kept in continuous operation, do only the procedures that can be done without disturbing operation. Make complete checks and services when the equipment is shut down.

Table 2-1. Operator Preventive maintenance Checks and Services for Model PEU-155/E

Item No.	Interval	Location	Procedure	Not fully Mission Capable If:
		Item to Check/Service		
1	Before	Enclosure	Inspect for obvious damage to enclosure or door assemblies	Internal wiring is exposed Cover will not close properly.
2	Before	Endosure	Inspect cover assembly including hinge and gasket.	
3	Before	Endosure	Check drainage openings in endosure lower comers and dean if necessary.	
4	Before	Top Panel	Check for damaged circuit breakers	Circuit breakers are damaged so as to affect function or safety.
5	Before	Top Panel	Check operation of sliding bar assembly	Sliding bar is damaged so that it will not function properly.
6	Before	Top Panel	Check that indicator lights are present and unbroken.	Connectors are damaged Covers or gaskets are missing or unserviceable. Cable connectors are damaged Bare wires are exposed. Ground wires are frayed or missing
7	Before	Connectors	Inspect connectors for damage	
8	Before	Connectors	Inspect connector covers	
9	Before	Cable assemblies	Check for damaged cable connectors	
10	Before	Cable assemblies	Check for split, cut, and damaged insulation.	
11	Before	Ground wires	Check that ground wires are securely attached to ground terminal(s).	
12	Before	Connectors	Check that unused connectors are capped.	
			<div style="border: 1px solid black; padding: 5px; display: inline-block;"><b>CAUTION</b></div>	
			<p>When input power is energized, all 3-phase indicator lights should illuminate. If all three lights are not illuminated, immediately turn off the input power and notify the next higher level of maintenance. Damage to the equipment being energized may occur if the problem is not corrected. Maintenance personnel should consult the troubleshooting chart, Table 3-1, to determine the problem.</p>	

**Table 2-1. Operator Preventive Maintenance checks maintenance checks and Services for Model PEU-155/E-  
Continued**

Item No.	Interval	Location Item to Check/Service	Procedure	Not fully Mission Capable If:
13	During	Top Panel	<p>Check that indicator lights glow when power is applied to associated load terminals</p> <div data-bbox="771 441 1023 535" style="border: 2px solid black; padding: 5px; text-align: center; margin: 10px 0;"> <p><b>WARNING</b></p> </div> <p>High voltage is present in this equipment during operation. Do not attempt making any repairs without first shutting down all input power from the power distribution panel. Failure to observe this warning could result in serious injury or death.</p>	Indicator light not glowing
14	After	Top panel	<p>Clean face of circuit breakers with a dry rag (item 5, Appendix E). Wipe internal and external surface with a damp, dean rag.</p>	
15	After	Connectors	<p>Check that unused connectors are capped</p> <div data-bbox="763 966 1015 1060" style="border: 2px solid black; padding: 5px; text-align: center; margin: 10px 0;"> <p><b>WARNING</b></p> </div> <p>High voltage is present in this equipment during operation. Do not attempt making any repairs without first shutting down all input power from the power distribution panel. Failure to observe this warning could result in serious injury or death.</p>	
16	After	Cable assemblies	<p>Clean with a rag (item 5, Appendix E) soaked assemblies in mild detergent solution (item 2, Appendix E). Dry surface with a damp, dean rag (item 5, Appendix E).</p>	

### SECTION III. OPERATION UNDER USUAL CONDITIONS

#### NOTE

In addition to this section, manuals FM 20-31, Electrical Power Generation in the Field, and TM 9-6150-226-13, will provide useful and detailed information relating to electrical generators and DISE/PDISE equipment used with the power distribution panel.

#### 2.4 ASSEMBLY AND PRFPARATION FOR USE.

<b>WARNING</b>
----------------

The power distribution panel and associated cables are heavy and may be awkward to handle. Use correct lifting procedures and/or assistance from personnel to avoid injury.

#### NOTE

Considerations and calculations for field load equipment may be complicated. The commander should appoint a qualified soldier to plan the power network. The soldier shall consult and plan the power network with personnel familiar with electrical power distribution principles and calculations when available to the unit.

##### 2.4.1 Field Considerations.

2.4.1.1 When installing the power distribution panel at a field work site, one must first determine the physical location and electrical requirements of the equipment to be powered. Analyze each International Standardization Organization (ISO) container, Tent Extendable Modular Personnel (REMPER) tent, and van for its amperage needs to plan necessary cable runs. If data on quality of amperes needed by consuming is unavailable, one will have to estimate possible needs. Refer to FM 20-31 as a guide when making these estimates.

2.4.1.2 After you have determined quality of cables and location of user's equipment, study the terrain to determine the best way to route the cables to the Distribution Illumination Systems Electrical (DISE) equipment serving the ISO containers and TEMPER tents. Be familiar with tactical considerations or other factors that may restrict location of power sources relative to power consuming equipment.

2.4.1.3 Before actually installing the power distribution panel, one should develop a power distribution plan. This plan must take all factors mentioned into consideration. A good plan must allow for terrain and tactical constraints while providing adequate distributed power.

2.4.2 Load Considerations. Ensure that the total amperage of the load does not exceed the rated capacity of the power distribution panel or its individual branch circuits.

2.4.3 Generator Considerations. Choose the proper power source(s) to supply the power necessary to support the total load amperage.

2.4.4 Equipment Selection. The electrical values in Table 2-2 are an example based on a supposed situation; however, the procedures for this example are a method for you to correctly select the equipment needed for your particular field situation.

Table 2-2. Typical User Requirements

Item	Receptacle		Total kilowatts	Total amps	
	120V/1ph plug	208V/3-ph class L		1-ph	3-ph
<b>Tent No. 1</b>					
1. Electric drill 120 V/1800 W	1		0.800	6.6	6.6
2. Electric grinder 120 V/900 W	1		0.900	7.5	
3. Sander 120 V/450 W	1		0.450	3.75	
4. Radio Set 120 V/180 W	1		0.180	1.5	
5. Lights 120 V/60 W (6 ea)	6		0.360	3.0	
6. Welder 208 V/3-ph/600 W		1	1.600		4.5
<b>Total for Tent No. 1</b>	10	1	4.290	22.35	4.5
<b>Tent No. 2</b>					
1. Electric heater 120 V/1300 W	1		1.300	10.8	
2. Radio transceiver 120 V/1000 W	1		1.000	8.3	
3. Light set 120 V/60 W (6 ea)	1		0.360	3.0	
<b>Total for Tent No. 2</b>	3		2.660	22.1	
<b>Tent No. 3</b>					
1. X-ray unit 120 V/600 W	1		0.600	5.0	
2. Film processor 120 V/20 W	1		0.120	1.0	
3. Suction unit 120 V/140 W	1		0.140	1.2	
4. Prophylaxis unit 120 V/150 W	1		0.150	1.3	
5. Surgery lamp 120 V/1200 W	1		1.200	10.0	
6. Light Set 120 V/60 W (8 ea)	1		0.480	4.0	
<b>Total for Tent No. 3</b>	6		2.690	22.5	
<b>Total Requirements</b>	19	1	9.640	67.0	4.5

2.4.4.1 Determine the user's needs. Consult with each user and make a careful record of the electrical requirements of his electrical equipment (120/208 Vac, 50/60 Hz only) as follows:

**NOTE**

Voltage (E), amperage (I), and wattage (P) are mathematically calculated as follows:

**(1 -phase)**

$$P = E \times I$$

$$E = \frac{P}{I}$$

$$I = \frac{P}{E}$$

$$I = \frac{P}{E}$$

$$I = \frac{P}{E}$$

**(3-phase)**

$$P = 1.73 \times E \times I$$

$$E = \frac{P}{1.73 \times I}$$

$$I = \frac{P}{1.73 \times E}$$

$$I = \frac{P}{1.73 \times E}$$

2.4.4.1.1 Record the voltage rating (120 V/1-ph or 208 V/3-ph).

2.4.4.1.2 Record the amperage rating.

2.4.4.1.3 Record the wattage rating.

2.4.4.1.4 Record the number of receptacles (outlets) required.

2.4.4.1.5 Draw up a table of these values as illustrated in Table 2-2.

2.4.4.1.6 Add up the total! watt load (9640 watts for the example). Change this value to kilowatts (divide by 1000) (9.6 kW for the example).

2.4.4.1.7 Select power generation equipment with enough capacity to support this load.

2.4.4.1.8 Cable Selection Choice of power output cables should be based on amperage requirements and distances between locations selected for the generator set(s), the power distribution panel, DISE equipment, and the shelters, vans, and tents. Remember, the longer the cable the greater the voltage loss at the user's end. Keep total! cable lengths between generator set and user equipment under 250 feet (76.20 m). If the user equipment is sensitive to voltage loss, shorter cables may have to be used.



High voltage is present in this equipment during operation. Do not submerge cable connectors in water. Failure to observe this warning could result in serious injury or death.



Bury cables which cross roadways. Power cables can be damaged by tactical vehicles.

2.4.5 Cable Routing. Route the system cables to avoid vehicle roadways and troop walkways. If a cable must cross a roadway, bury the cable to protect it from damage, refer to FM 20-31. Do not lay cable connectors in depressions where water can collect.

**WARNING**

High voltage is present in this equipment during operation. Turn off power generator equipment and set all circuit breakers to OFF before connecting cables.

2.4.6 Connection of Cables. Connect 60 and 100-amp power cables to power distribution panel connectors or to each other as dictated by the power distribution plan. Use lubricant (item 3, Appendix E) to aid in mating power cable connectors.

2.4.7 Connection to Generator Set.

**WARNING**

- High voltage is present in this equipment during operation. Do not connect cables to the generator set with the power on. Death or severe injury may result.
- Ground the generator set. Death or severe injury may result if the generator set is not properly grounded.

2.4.7.1 Physically check that generator set is properly grounded. Refer to applicable technical manual for grounding.

**CAUTION**

Individual input power cables are banded at both ends to identify phasing, neutral, and ground. Make certain when connecting to generator that you are connecting the correct cable between corresponding lead terminals.

2.4.7.2 Connect one end of power distribution panel input power cables to generator set load terminals. Observe cable markings and connect PHASE A to L1, PHASE B to L2, PHASE C to L3, NEUTRAL to LO, and GROUND to ground.

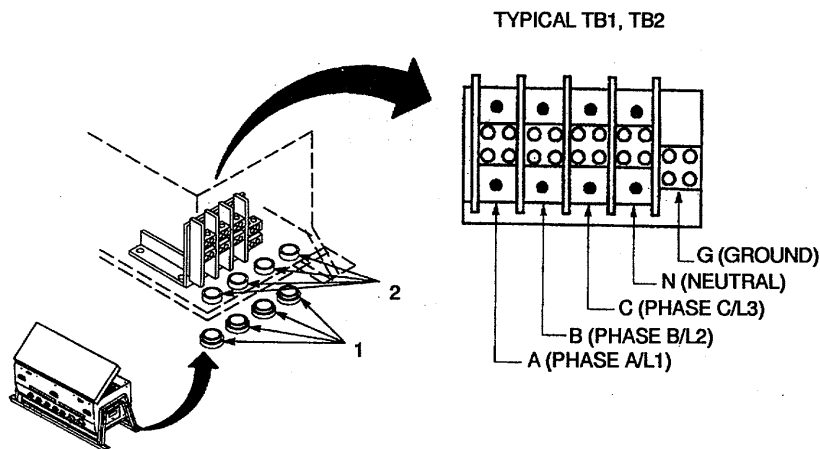

Figure 2-4. Power Connection Terminal.



2.4.7.3 Open access panel and remove by sliding off of hinges. Remove dust covers (1, Figure 2-4) and stow inside access cover.

2.4.7.4 Observe cable marking and route through entry bushing (2) to TB1 or TB2, as required. Observe cable markings and connect PHASE A (L1) to TB1 -A, PHASE B (L2) to TB1 -B, PHASE C (L3) to TB1 -C, NEUTRAL (LO) to TB1 -N and GROUND to TB1 -G. Torque set screws in accordance with Appendix H.

2.4.7.5 Install access door by sliding onto hinges, then close door.

2.4.8 Grounding the Power Distribution Panel. Grounding of the power distribution panel is through the generator set ground rod and ground cable.

## 2.5 OPERATING PROCEDURES.

### **WARNING**

High voltage is present in this equipment during operation. Make certain all unused connectors are covered to prevent electrical shock. Death serious injury may result.

### **CAUTION**

- Never block circuit breaker switches in the ON position. Excessive current will damage equipment.
- Make certain upper door assemblies are closed and secured to prevent rain water from entering power distribution panel.

### **NOTE**

Refer to applicable technical manuals and FM 2031 for operating procedures for the power generation equipment in use.

## 2.5.1 Starting Procedures.

### **WARNING**

High Voltage is present in this equipment during operation. Before turning on electrical power, alert all users. Failure to observe this warning could result in serious injury or death.

- 2.5.1.1 Set both main circuit breakers to the OFF position.
- 2.5.1.2 Set All branch circuit breakers to the OFF position.
- 2.5.1.3 Refer to applicable TM for operating procedures and start the generator set.
- 2.5.1.4 Set main circuit breaker to ON position.
- 2.5.1.5 Observe DS1, DS2, and DS3, for indication of power at power distribution panel.
- 2.5.1.6 One by one, set circuit breakers for branch circuits being used to ON position.

- 2.5.2. Operation. Advise users that power distribution panel is operational.
- 2.5.3. Resetting the Circuit Breakers.
  - 2.5.3.1 A circuit breaker in the tripped position (midway between ON and OFF positions) indicates the circuit breaker has been subjected to an overload condition. Wait 2 minutes before resetting the circuit breaker. To reset the circuit breaker, move the switch to the OFF position and then to the ON position.
  - 2.5.3.2 If the circuit breaker trips again after resetting, the overload or fault must be cleared before safe operation can be resumed. If no fault or overload condition is detected, troubleshoot the electrical circuit (Table 3-1).
  - 2.5.3.3 A circuit breaker in the OFF position indicates the circuit breaker has not been operated.
- 2.5.4. Shutdown Procedures.
  - 2.5.4.1 Shut down user's equipment.
  - 2.5.4.2 Set individual branch circuit breakers to OFF position.
  - 2.5.4.3 Set both MAIN 1 and MAIN 2 circuit breakers to OFF position.
  - 2.5.4.4 Refer to applicable technical manuals and shut down the generator set.

**2.6 DECALS AND INSTRUCTION PLATES (FIGURE 2-6).** The decals and instruction plates are affixed to the power distribution panel at various locations. These plates and decals provide information, instructions, identification, and connections for operating and maintaining the power distribution panel. These decals and plates are shown individually following the locator views.

LEGEND

1. Information Plate, WIRING DIAGRAM 100 KW POWER DISTRIBUTION PANEL.
2. Decal Strip, Circuit Breakers 3, 5, 7, 9, 11, 13 and 15.
3. Decal Strip, Circuit Breakers 4, 6, 8, 10, 12, 14 and 16.
4. Decal Strip, connectors, nine 60 Amps, eleven 60 Amps, thirteen 60 Amps, fifteen 60 Amps.
5. Information Plate, Manufacturer's Nameplate.
6. Decal Strip, connectors three 1 00 Amps, five 1 00 Amps, seven 60 Amps.
7. Information Decal, Circuit Breaker MAIN one 400 AMPS 30.
8. Information Decal, INPUT LINE 1 TERMINAL BLOCKS INSIDE.
9. Information Decal, WARNING LETHAL VOLTAGES PRESENT.
10. Information Decal, 120/208 VOLTS.
11. Information Decal, INTERLOCK OPERATION.
12. Information Decal, Circuit Breaker MAIN two 400 AMPS 30.
13. Decal Strip, A B C.
14. Decal Strip, connectors eight 60 Amps, six 1 00 Amps, four 1 00 Amps.
15. Decal Strip, connectors sixteen 60 Amps, fourteen 60 Amps, twelve 60 Amps, ten 60 Amps.
16. Information Decal, Fork Lift.
17. Information Decal, TERMINAL BLOCK LAYOUT (Inside Access Door).
18. Information Decal, INPUT LINE 2 TERMINAL BLOCKS INSIDE.
19. Information Decal, GROUND.

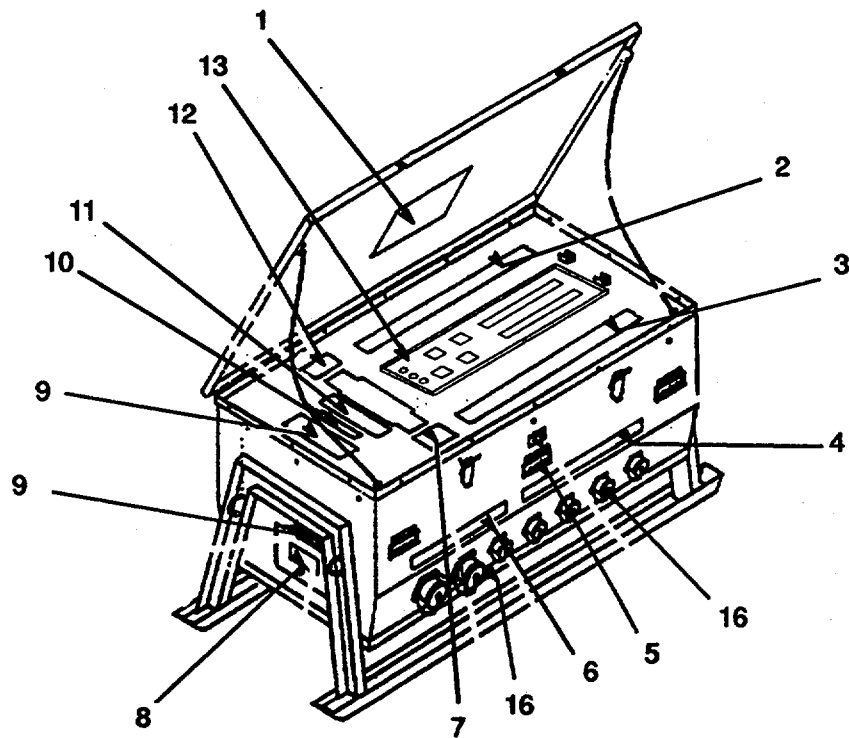

FRONT VIEW

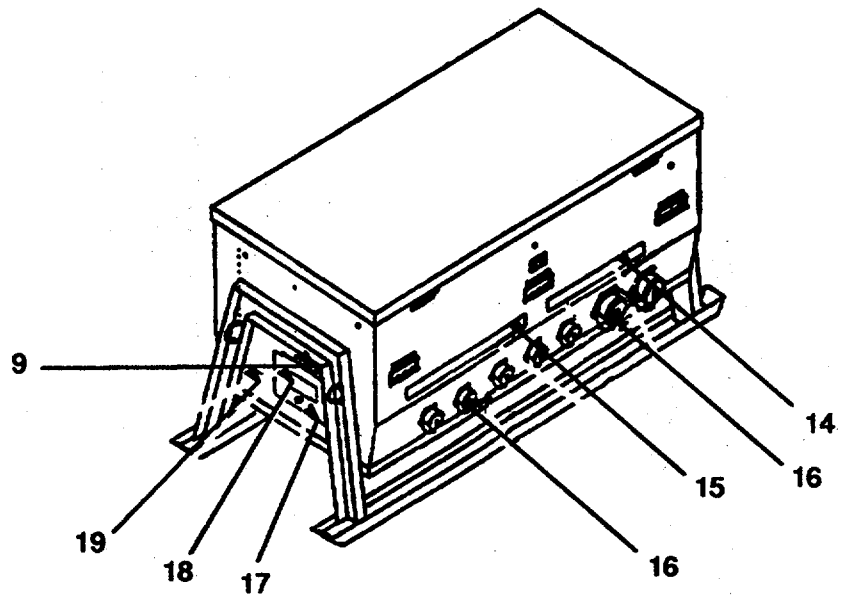

REAR VIEW

Figure 2-5. Decal and Instruction Plato Location.

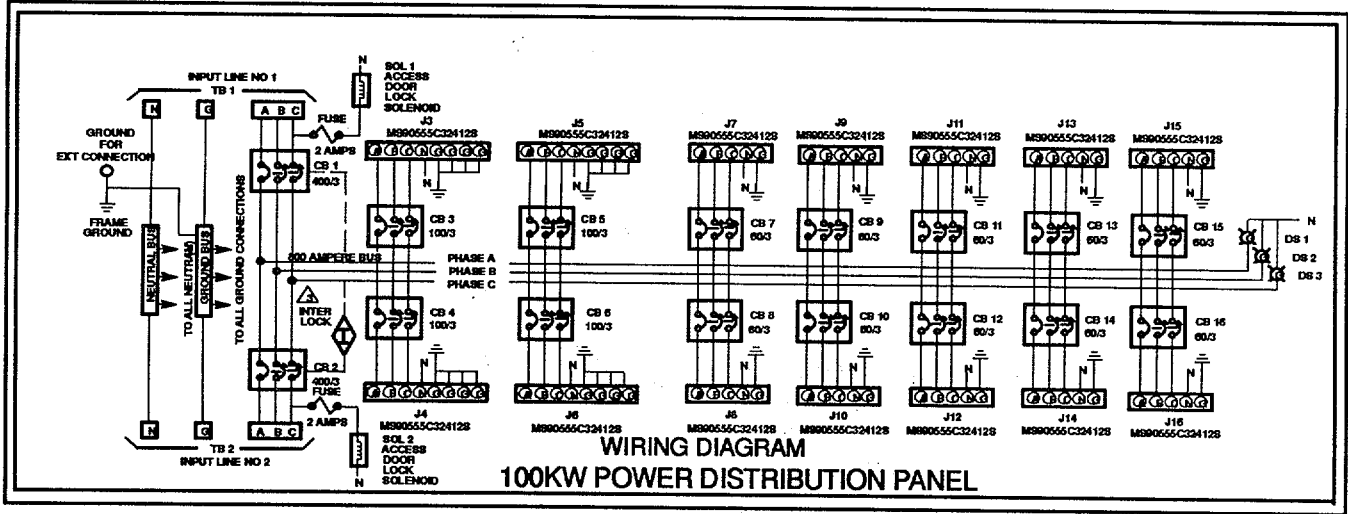

1. WIRING DIAGRAM INFORMATION PLATE



3. CIRCUIT BREAKERS DECAL STRIP

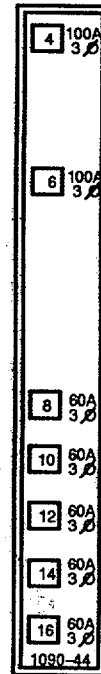

2. CIRCUIT BREAKERS DECAL STRIP

Figure 2-6. Power Districution Panel Decal and Information Plates (Sheet 1 of 3).



4. CONNECTORS DECAL STRIP

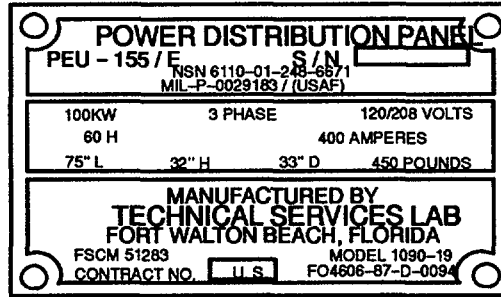

5. MANUFACTURER'S NAMEPLATE INFORMATION PLATE



6. CONNECTORS DECAL STRIP

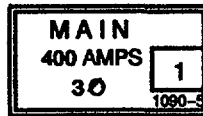

7. CIRCUIT BREAKER INFORMATION DECAL

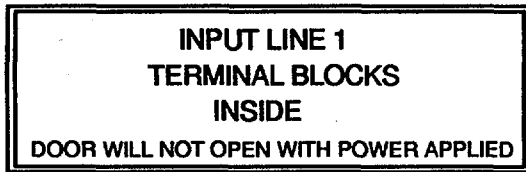

8. TERMINAL BLOCKS INFORMATION DECAL

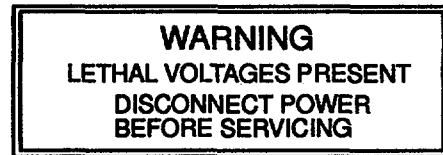

9. WARNING LETHAL VOLTAGES PRESENT INFORMATION DECAL

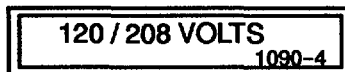

10. 120 / 208 VOLTS INFORMATION DECAL

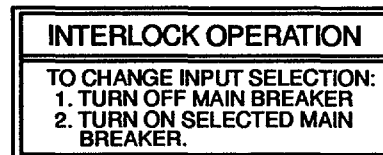

11. INTERLOCK OPERATION INFORMATION DECAL

Figure 2-6. Power Distribution Panel Decal and Information Plates (Sheet 2 of 3).

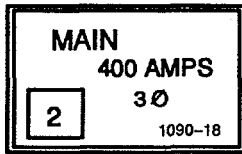

12. CIRCUIT BREAKER INFORMATION DECAL



13. PHASE INDICATOR DECAL STRIP



14. CONNECTORS DECAL STRIP



15. CONNECTORS DECAL STRIP



16. FORK LIFT INFORMATION DECAL

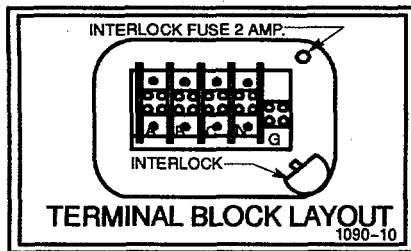

17. TERMINAL BLOCK LAYOUT INFORMATION DECAL

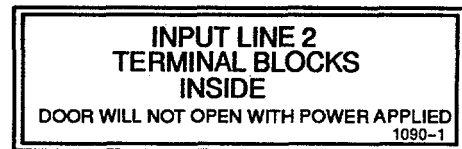

18. TERMINAL BLOCKS INFORMATION DECAL



19. INFORMATION DECAL - GROUND

Figure 2-6. Power Distribution Panel Decal and Information Plates (Sheet 3 of 3).

## **2.7 OPERATION OF AUXILIARY EQUIPMENT**

2.7.1 Power Generation Equipment. Refer to the Modified Table of Organization and Equipment (MTOE) for a listing of generator sets used to supply power to the power distribution panel. Refer to the applicable TM and to FM 20-31 for operating instructions.

2.7.2 DISE Equipment. Refer to TM 946150-226-13 for operating instructions for the various components of DISE equipment used with the power distribution panel.

## **2.8 PREPARATION FOR MOVEMENT.**

### **WARNING**

High voltage is present in this equipment during operation. Do not attempt to disconnect the equipment with electrical power on. Failure to observe this warning could result in serious injury or death.

### **CAUTION**

Dirt and contamination may plug connector sockets. Secure cap on connectors when disassembling the equipment

- 2.8.1 Shut down the power distribution panel. Refer to paragraph 2.5.4.
- 2.8.2 Starting at the user's end, disconnect power cables and cover cable connectors.
- 2.8.3 At the power distribution panel, disconnect power cables, cover cable connectors, and coil cables.
- 2.8.4 Disconnect input power cables from power distribution panel and generator(s) and coil cables and install all electrical connector covers.
- 2.8.5 Perform the after preventive maintenance checks and services in Table 2-1.
- 2.8.6 Install caps on output connectors, dose iower doors and top cover, and secure al latches.

## **SECTION IV. OPERATION UNDER UNUSUAL CONDITIONS**

### **2.9 OPERATION IN EXTREME COLD**

### **WARNING**

Do not touch cold metal parts with bare hands. Frostbite can cause permanent injury.

- 2.9.1 This equipment is designed for operation at temperatures as low as -25°F (-320C).
- 2.9.2 Cap unused connectors to protect against moisture.

- 2.9.3 Close and latch the top cover to protect against moisture.
- 2.9.4 When coiling power cables, form large loops. Power cables are difficult to coil in sub-zero weather.

**2.10 OPERATION IN EXTREME HEAT.**

- 2.10.1 Provide a shelter for the power distribution panel to protect against sun. If sheltered area is not available, make a shade from the sun with canvas, tarp, or camouflage netting.
- 2.10.2 Close and latch the power distribution panel top cover to protect against sun.
- 2.10.3 The power distribution panel must be well ventilated.

**2.11 OPERATION IN DUSTY OR SANDY AREAS.**

- 2.11.1 Shield the power distribution panel from blowing dust and sand. Take advantage of natural barriers which offers protection from sand and dust.
- 2.11.2 Cap unused connectors to protect against sand and dirt.
- 2.11.3 Close and latch the power distribution panel top cover to protect against sand and dirt.

**2.12 OPERATION IN RAINY OR HUMID CONDITIONS.**



High voltage is present in this system. Do not allow power distribution panel or cable connectors to be submerged in water. Death or severe injury may result.

- 2.12.1 Take special precautions to keep power distribution panel dry. If possible, provide a shelter for the equipment. If sheltered area is not available, cover the power distribution panel with canvas/strap.
- 2.12.2 Do not allow power distribution panel or cable connectors to be submerged in water.
- 2.12.3 Cap unused connectors to protect against moisture.
- 2.12.4 Close and latch the power distribution panel top cover to protect against moisture.
- 2.1 2.5 Check that the generator set is properly grounded.

**2.13 OPERATION IN SALTWATER AREAS.**



High voltage is present in this system. Do not allow power distribution panel or cable connectors to be submerged in water. Death or severe injury may result.

- 2.13.1 Take special precautions to keep power distribution panel dry. If possible, provide a shelter for the equipment. If a sheltered area is not available, cover the power distribution panel with canvas/tarp.
- 2.13.2 Do not allow distribution panel or cable connectors to be submerged in water.



2.13.3 Cap unused connectors to protect against moisture.

2.13.4 Close and latch the power distribution panel top cover to protect against moisture.

2.13.5 If this equipment is operated in a saltwater area for an extended period of time, perform the following at weekly intervals.

2.13.5.1 Shut down the generator sets.

2.13.5.2 Disconnect the power distribution panel from the cables.

2.13.5.3 Clean the face of the circuit breakers with a dry rag (item 5, Appendix E).

2.13.5.4 Wipe exposed surfaces of the power distribution panel with a damp, dean rag (Item 5, Appendix E).

2.13.5.5 Allow panel to dry thoroughly.

2.13.5.6 Reconnect the power distribution panel to the cables.

2.13.5.7 Refer to paragraph 2.5 and restart the system.

**2.14 EMERGENCY PROCEDURE.**

**CAUTION**

Life support systems and other essential services must not be interrupted. When a circuit overload is the problem, shutting down nonessential service loads may alleviate the overload temporarily until the problem is resolved.

2.14.1 In the event of partial equipment failure, it may be possible to maintain a limited electrical power network In this situation, contact unit maintenance for assistance in developing an alternate plan for power distribution.

2.14.2 In case of complete failure of the power distribution panel, shut down generator(s) and reconnect the generator sets directly to the various DISE/PDISE feeder boxes according to tactical priority of the associated user's equipment.

CHAPTER 3

OPERATOR MAINTENANCE INSTRUCTIONS

SECTION I. LUBRICATION INSTRUCTIONS

**3.1 LUBRICATION.** Lubricate access door and top cover hinges and six handles every six months with an all purpose lubricating oil.

SECTION II. TROUBLESHOOTING PROCEDURES

**3.2 INTRODUCTION.**

3.2.1 Table 3-lists the common malfunctions which one may find during the operation or maintenance of the power distribution panel. One should perform the tests/inspections and corrective actions in the order listed.

3.2.2 Before troubleshooting the power distribution panel, make certain the malfunction in the system is not originating at either the user's equipment or the associated DISE/PDISE feeder center. Refer to TM 9-6150-226-13 for troubleshooting procedures applicable to DISE/PDISE equipment.

3.2.3 This manual cannot list all malfunctions that may occur, nor all tests or inspections and corrective actions. If a malfunction is not listed or is not corrected by listed corrective actions, notify your supervisor.

**3.3 SYMPTOM INDEX.**

Symbol	Troubleshooting Procedure (Para)
Circuit breaker supporting user's load repeatedly trips.....	3.4.2
User's equipment operates erratically or too slowly .....	3.4.3
User's equipment will not operate.....	3.4.1

3.4 OPERATOR TROUBLESHOOTING.

Table 31. Operator Troubleshooting

1. USER'S EQUIPMENT WILL NOT OPERATE.

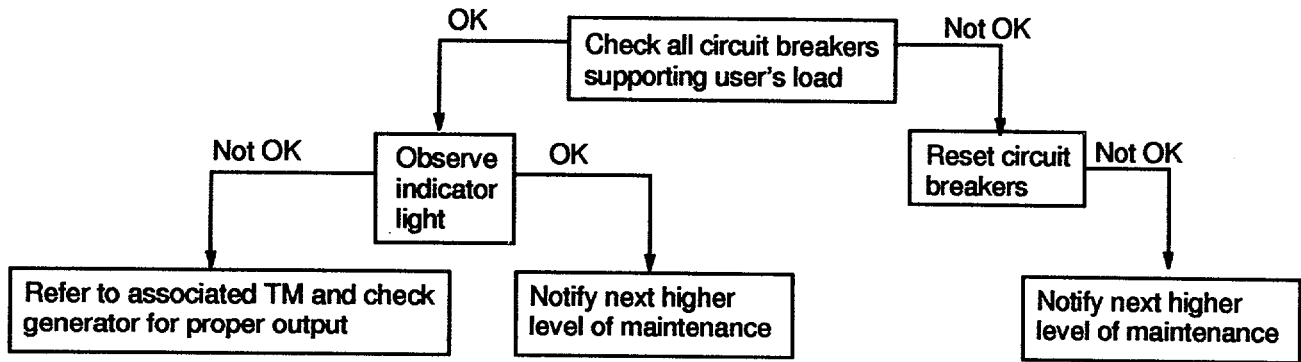

2. CIRCUIT BREAKER SUPPORTING USER'S LOAD REPEATEDLY TRIPS.

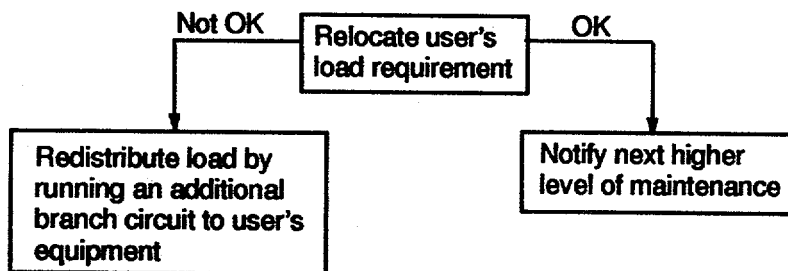
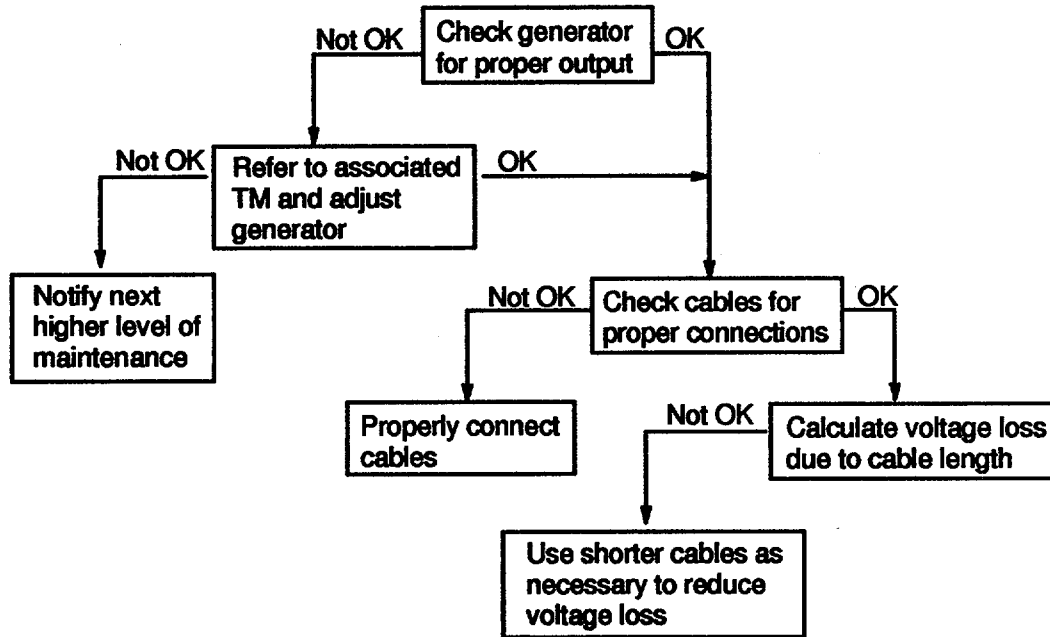

Table 3-1. Operator Troubleshooting - CONT

3. USER'S EQUIPMENT OPERATES ERRATICALLY OR TOO SLOWLY



SECTION III. MAINTENANCE PROCEDURES

3.5 GENERAL



High voltage is present in this system. Do not dean components with the power on. Death or serious injury may result

Operator maintenance of the power distribution panel is limited to inspection and cleaning. Refer to operator PMCS (Table 2-1) for the necessary procedures.

3.6 INSPECTION.

Inspect power distribution panel in accordance with Table 2-1.

3.7 REPAIR.

There are no repair procedures for the power distribution panel authorized at the operator level.

CHAPTER 4

UNIT MAINTENANCE INSTRUCTIONS

SECTION I. REPAIR PARTS; TOOLS; SPECIAL TOOLS; TEST, MEASUREMENT, AND DIAGNOSTIC EQUIPMENT(TMDE); AND SUPPORT EQUIPMENT

4.1 **INTRODUCTION.** Power generator equipment repairer, is authorized to perform all unit maintenance on the power distribution panel.

4.2 **COMMON TOOLS AND EQUIPMENT.** For authorized common tools and equipment, refer to the Modified Table of Organization and Equipment (MTOE) applicable to your unit.

4.3 **SPECIAL TOOLS, TMDE, AND SUPPORT EQUIPMENT.** Refer to Appendix B, Maintenance Allocation Chart, and Appendix F, Repair Parts and Special Tools List for a list of special tools, TMDE, and support equipment.

4.4 **REPAIR PARTS.** Repair parts are listed and illustrated in Appendix F.

SECTION II. SERVICE UPON RECEIPT

4.5 **SERVICE UPON RECEIPT OF MATERIAL.**

4.5.1 Refer to Table 4-1 and perform the actions listed.

4.5.2 Refer to Tables 4-4 and 4-5 and perform continuity checks.

*Table 4-1. Service Upon Receipt Checklist.*

Item	Location	Action	Remarks
1	Power distribution panel	a. Inspect circuit breaker switches for cracks and freedom of movement b. Inspect connectors for missing covers. c. Inspect connector receptacles for distorted or damaged sockets. d. Inspect indicator lights for cracked lens, damaged or missing bulbs. e. Inspect for missing or damaged latches. f. Inspect connectors for proper key alignment.	
2	Cables	a. Inspect for missing connector covers. b. Inspect for missing, bent, or loose connector pins. c. Inspect for distorted or damaged connector sockets. d. Inspect for split, cut, or damaged insulation.	
3	Input power cables	Inspect for spilt, cut, or damaged insulation.	

**4.6 CHECK UNPACKED EQUIPMENT.**

4.6.1 Inspect the equipment for damage incurred during shipment. If the equipment has been damaged, report the damage on SF 364, Report of Discrepancy.

4.6.2 Check the equipment against the packing list to see if the shipment is complete. Report all discrepancies in accordance with the instructions of DA PAM 738-750.

4.6.3 Check to see whether the equipment has been modified.

**SECTION III. UNIT PREVENTIVE MAINTENANCE CHECKS AND SERVICES  
(PMCS)**

**4.7 INTRODUCTION.**

4.7.1 PMCS Requirements. This section contains unit PMCS requirements for the power distribution panel. Table 4-2 contains checks and services necessary to ensure that the equipment is ready for operation. Use the PMCS table and perform maintenance at the specified intervals.

4.7.2 Item Numbers. Item numbers are assigned in chronological ascending sequence regardless of interval designation. These numbers are used for your "TM number" column on DA Form 2404, Equipment Inspection and Maintenance Work Sheet, in recording the results of PMCS.

4.7.3 Interval Column. This column determines the time period designated to perform PMCS.

4.7.4 Item To Be Inspected Column. The columns list functional group assemblies and subassemblies as shown on the maintenance allocation chart. The appropriate check or service procedure follows the specific item to be inspected.

4.7.5 Procedure Column. This column gives the procedure you must do to check or service the item listed in the Check/Service column to know if the equipment is ready or available for its intended mission or for operation. You must do the procedure at the time stated in the interval column.

**4.8 PMCS INSTRUCTIONS.**

4.8.1 Always perform your PREVENTIVE MAINTENANCE tasks in the listed order.

4.8.2 If you discover a maintenance problem while performing PMCS, troubleshoot it with the instructions in Section IV. Report defective components to higher level of maintenance.

4.8.3 When performing PMCS, take along the tools and supplies needed to make all checks.

4.8.4 Remove the deadfront panel assembly (para 4.13) and open all lower door assemblies to enable a complete inspection.

**NOTE**

If the power distribution panel must be kept in continuous operation, check and service only those items that can be checked and serviced without disturbing operation. Make the complete checks and services when the equipment can be shut down.

**Table 4-2. Unit Preventive Maintenance Checks and Services.**

Item No.	S-Semi-annually		Item to be Inspected	A-Annually
	Interval			Procedure
	S	A		
				<b>WARNING</b>
1	•		Power distribution panel interval wiring	High voltage is present in this equipment. Do not perform PMCS with the power on. Death or serious injury may result. Check internal wiring for secure connections.
2	•		Circuit breakers	Check for burnt insulation and signs of overheating. Check for secure mounting to circuit breaker support assembly.
3		•	Bus bars	Check for secure mounting and signs of damage.
4		•	Indicator lights	Check for secure mounting and missing or broken bulbs.
5	•		Internal surfaces	Check for corrosion and mildew.
6	•		Connectors	Check for missing gaskets or hardware and secure mounting in distribution panel.
7	•		Circuit breaker wire terminals	Check torque in accordance with Table H-1.
8	•		Bus bars	Check terminations of cables from circuit breakers and connectors.

**SECTION IV. UNIT TROUBLESHOOTING**

**4.9 INTRODUCTION.**

4.9.1 This section contains troubleshooting information and tests for isolating faults which may develop in the power distribution panel. When the cause of a problem has been identified using test procedures authorized at the unit level, it is reported to the next higher level of maintenance. Most components of the power distribution panel are authorized for repair at the direct support level of maintenance. See Maintenance Allocation Chart (MAC) in Appendix B.

4.9.2 Keep in mind that this manual addresses only the power distribution panel. Refer to appropriate technical manuals to identify problems caused by the power generation equipment. Refer to TM 9-61 50-226-13 for troubleshooting procedures applicable to DISE/PDISE equipment.

**4.10 SYMPTOM INDEX.**

Symptom	Troubleshooting Procedure (Para)
Circuit breaker supporting user's load repeatedly trips.....	4.11.3
Equipment powered through the power distribution panel will not operate (output from power generation equipment has been verified at source).....	4.11.2
User's equipment powered by one or all output connectors does not operate.....	4.11.1

**4.11 UNIT TROUBLESHOOTING.**

4.11.1 General.

4.11.1.1 The common malfunctions which one may encounter during operation or maintenance of the power distribution panel are listed in Table 4-3. Perform the tests, inspections, and corrective actions in the order listed.

4.11.1.2 This manual cannot list all the malfunctions that may occur, nor all tests or inspections and corrective actions possible. If a malfunction is not listed, or is not corrected by listed corrective actions in this manual, then notify supervisor.

4.11.2 Troubleshooting Instructions. Unit troubleshooting lists the common malfunctions which can occur during the operation of the power distribution panel. Each malfunction for an individual component or system is followed by a list of tests or inspections and corrective actions to take.



High voltage is present in this system. Do not make continuity checks with the power on. Death or serious injury may result.



4.11.3 Phase Designation. Electrical phases are designated with one of two designations as follows:

4.11.3.1 Phase A or L1.

4.11.3.2 Phase B or L2.

4.11.3.3 Phase C or L3.

4.11.3.4 Neutral (N) or LO.

4.11.4 Wiring Designation. Internal wiring in the power distribution panel is marked with wire numbers to identify connection points of the individual wires. Refer to Table 4-6 for wire markings.

4.11 .5 Internal wiring insulation is color coded to identify phasing. Insulation colors are as follows:

BLACK - phase A or L1  
RED - phase B or L2  
BLUE - phase C or L3  
WHITE - Neutral or LO  
GREEN - ground (GND)

4.11.6 Electrical Fault Isolation. To isolate a short or open drcuit, use a multimeter (Item 1, Appendix B). Refer to the troubleshooting guide (Table 4-3) and the appropriate continuity checklist (Tables 4-4 and 4-5), and the wire run list (Table 4-6). A measurement of continuity between two points listed in the tables as having no continuity indicates a short drcuit. A measurement of no continuity between two points listed in the tables as having continuity indicates an open drcuit. Refer to FO-1 for a schematic diagram of the power distribution panel.

Table 4-3. Unit Troubleshooting.

1. USER'S EQUIPMENT POWERED BY ONE OR ALL OUTPUT CONNECTORS DOES NOT OPERATE (OUTPUT FROM POWER GENERATOR HAS BEEN VERIFIED AT SOURCE).

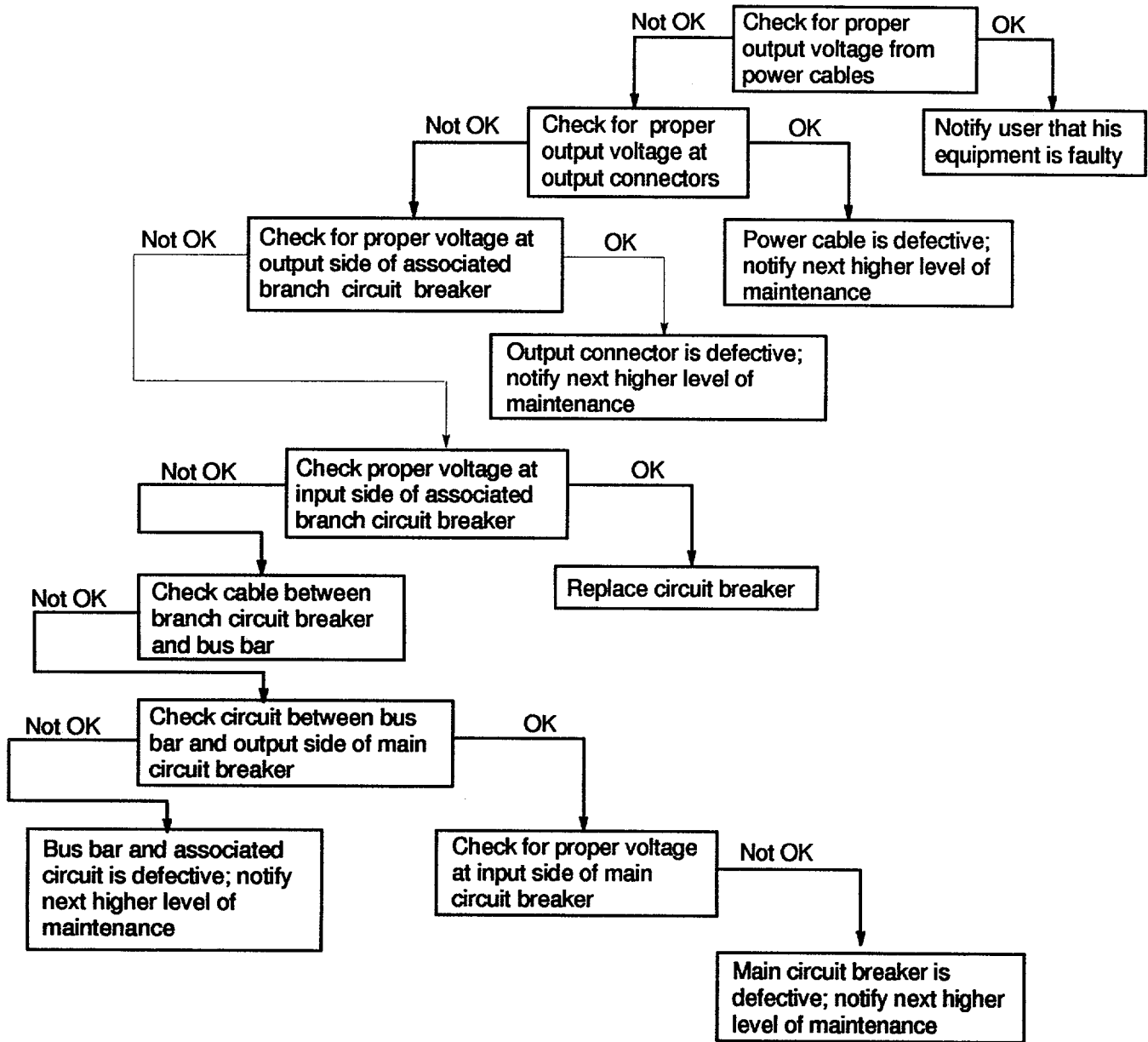

Table 4-3. Unit Troubleshooting - continued.

2. EQUIPMENT POWERED THROUGH THE POWER DISTRIBUTION PANEL WILL NOT OPERATE (OUTPUT FROM POWER GENERATION EQUIPMENT HAS BEEN VERIFIED AT SOURCE).

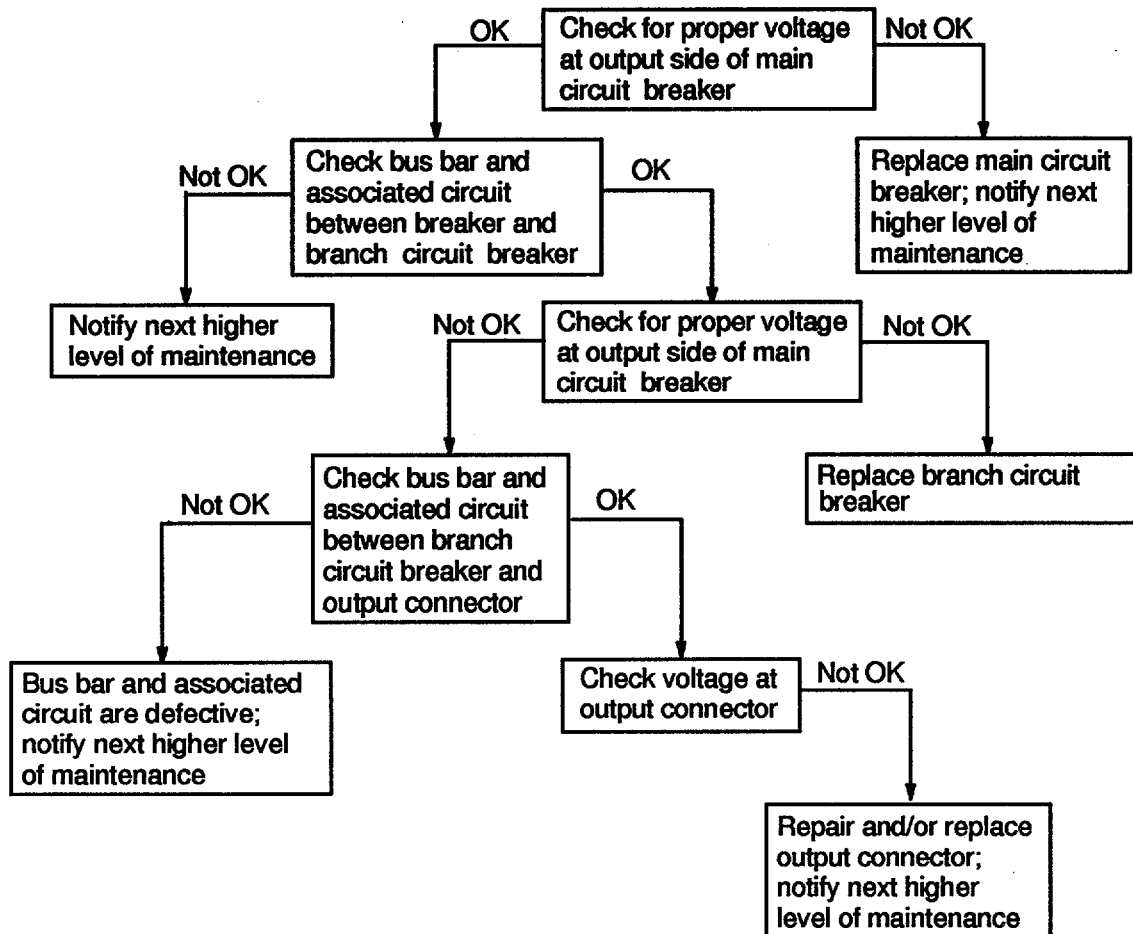
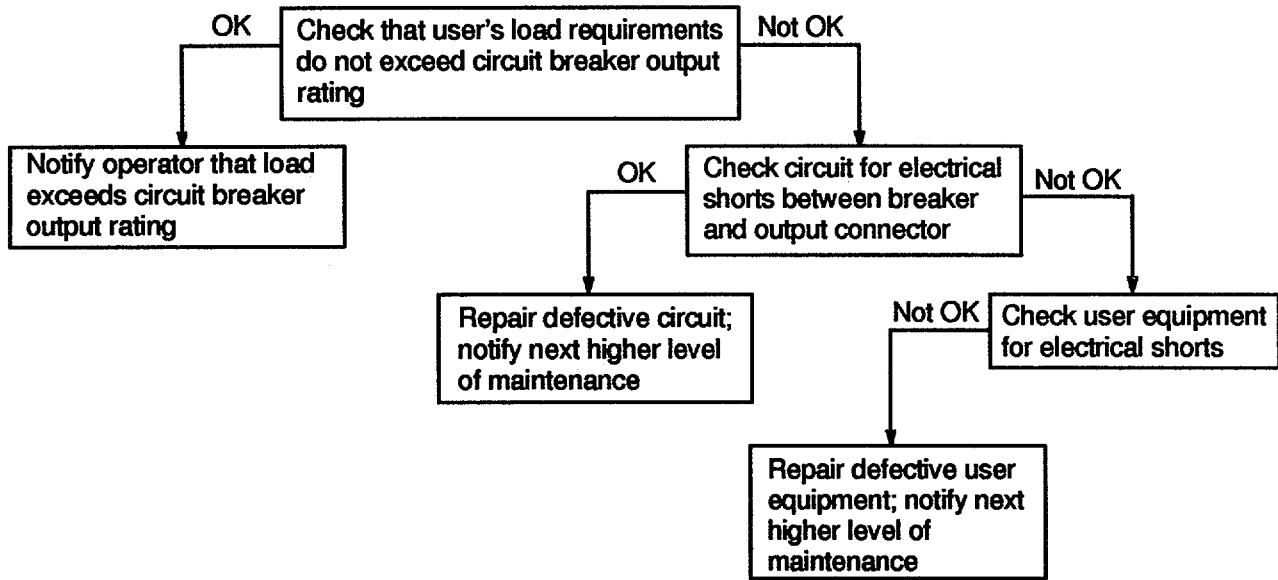

Table 4-3. Unit Troubleshooting - continued.

3. CIRCUIT BREAKER SUPPORTING USER'S LOAD REPEATEDLY TRIPS.



**Table 4-4. Power Distribution Panel Continuity Checks**

**NOTE**

1. Gain access to terminal blocks TB1 and TB2, refer to para 4.17.
2. Remove Phase A, B and C light bulbs DS1-DS-3, refer to para 4.15.
3. Place MAIN 1, MAIN 2, all 60 and 100 amp drcuit breakers CB1 -CB1 6 to dosed (ON) position.
4. Perform continuity checks from TB1, then, TB2, Refer to back of access panel for terminal blocks TB1 and TB2 layout.
5. Upon completion, install phase A, B, and C light bulbs (para 4.15). Install and dose access panel (para4.17). Place all circuit breakers to open (OFF) position.

X Indicates continuity.  
 O Indicates no continuity.

<b>TB1 and TB2</b>	<b>A (Phase B)</b>	<b>B (Phase B)</b>	<b>C (Phase C)</b>	<b>N (Neutral)</b>	<b>G (Ground)</b>
J3-A	X	O	O	O	O
J3-B	O	X	O	O	O
J3-C	O	O	X	O	O
J3-N	O	O	O	X	O
J3-G1	O	O	O	O	X
J3-G2	O	O	O	O	X
J3-G3	O	O	O	O	X
J3-G4	O	O	O	O	X
J4-A	X	O	O	O	O
J4-B	O	X	O	O	O
J4-C	O	O	X	O	O
J4-N	O	O	O	X	O
J4-G1	O	O	O	O	X
J4-G2	O	O	O	O	X
J4-G3	O	O	O	O	X
J4-G4	O	O	O	O	X
J5-A	X	O	O	O	O
J5-B	O	X	O	O	O
J5-C	O	O	X	O	O
J5-N	O	O	O	X	O
J5-G	O	O	O	O	X
J5-G2	O	O	O	O	X
J5-G3	O	O	O	O	X
J5-G4	O	O	O	O	X

**Table 4-4. Power Distribution Panel Continuity Checks - continued**

<b>TB1 and TB2</b>	<b>A (Phase B)</b>	<b>B (Phase B)</b>	<b>C (Phase C)</b>	<b>N (Neutral)</b>	<b>G (Ground)</b>
J6-A	X	O	O	O	O
J6-B	O	X	O	O	O
J6-C	O	O	X	O	O
J6-N	O	O	O	X	O
J6-G1	O	O	O	O	X
J6-G2	O	O	O	O	X
J6-G3	O	O	O	O	X
J6-G4	O	O	O	O	X
J7-A	X	O	O	O	O
J7-B	O	X	O	O	O
J7-C	O	O	X	O	O
J7-N	O	O	O	X	O
J7-G	O	O	O	O	X
J8-A	X	O	O	O	O
J8-B	O	X	O	O	O
J8-C	O	O	X	O	O
J8-N	O	O	O	X	O
J8-G	O	O	O	O	X
J9-A	X	O	O	O	O
J9-B	O	X	O	O	O
J9-C	O	O	X	O	O
J9-N	O	O	O	X	O
J9-G	O	O	O	O	X
J10-A	X	O	O	O	O
J10-B	O	X	O	O	O
J10-C	O	O	X	O	O
J10-N	O	O	O	X	O
J10-G	O	O	O	O	X
J11-A	X	O	O	O	O
J11-B	O	X	O	O	O
J11-C	O	O	X	O	O
J11-N	O	O	O	X	O
J11G	O	O	O	O	X

**Table 4-4. Power Distribution Panel Continuity Checks continued**

<b>TB1 and TB2</b>	<b>A (Phase B)</b>	<b>B (Phase B)</b>	<b>C (Phase C)</b>	<b>N (Neutral)</b>	<b>G (Ground)</b>
J12-A	X	O	O	O	O
J12-B	O	X	O	O	O
J12-C	O	O	X	O	O
J12-N	O	O	O	X	O
J12-G	O	O	O	O	X
J13-A	X	O	O	O	O
J13-B	O	X	O	O	O
J13-C	O	O	X	O	O
J13-N	O	O	O	X	O
J13-G	O	O	O	O	X
J14-A	X	O	O	O	O
J14-B	O	X	O	O	O
J14-C	O	O	X	O	O
J14-N	O	O	O	X	O
J14-G	O	O	O	O	X
J15-A	X	O	O	O	O
J15-B	O	X	O	O	O
J15-C	O	O	X	O	O
J15-N	O	O	O	X	O
J15-G	O	O	O	O	X
J16-A	X	O	O	O	O
J16-B	O	X	O	O	O
J16-C	O	O	X	O	O
J16-N	O	O	O	X	O
J16-G	O	O	O	O	X

**Table 4-5. Power Distribution Panel Continuity Checks**

X Indicates continuity.  
 O Indicates no continuity.

a. 100-amp, 8 wire Power Cables.

	<b>P1-A</b>	<b>P1-B</b>	<b>P1-C</b>	<b>P1-N</b>	<b>P1-G1</b>	<b>P1-G2</b>	<b>P1-G3</b>	<b>P1-G4</b>
P2-A	X	O	O	O	O	O	O	O
P2-B	O	X	O	O	O	O	O	O
P2-C	O	O	X	O	O	O	O	O
P2-N	O	O	O	X	O	O	O	O
P2-G1	O	O	O	O	X	X	X	X
P2-G2	O	O	O	O	X	X	X	X
P2-G3	O	O	O	O	X	X	X	X
P2-G4	O	O	O	O	X	X	X	X

b. 60-amp, 5-wire Power Cables.

	<b>P1-A</b>	<b>P1-B</b>	<b>P1-C</b>	<b>P1-N</b>	<b>P1-G</b>			
P2-A	X	O	O	O	O			
P2-B	O	X	O	O	O			
P2-C	O	O	X	O	O			
P2-N	O	O	O	X	O			
P2-G	O	O	O	O	X			



Table 4-6. Power Distribution Panel Wire List

FROM	STRIP LENGTH (IN.)		WIRE LENGTH (IN)	WIRE SIZE (AWG)	WIRE COLOR	WIRE MARKING	TO	STRIP LENGTH (IN.)
TB1A	1	8642559-1	37	250MCM	BLACK	1A	CB1A	0.75
TB1 B	1	8642559-1	37	250MCM	BLACK	1B	CB1B	0.75
TB1C	1	8642559-1	37	250MCM	BLACK	1C	CB1C	0.75
TB1N	1	8642559-1	19	250MCM	BLACK	1N	NEUT	0.75
TB1G	1	8642402-1	14	2 AWG	GREEN	1G	GRND	0.75
TB2A	1	8642559-1	75	250MCM	BLACK	2A	CB2A	0.75
TB2B	1	8642559-1	75	250MCM	BLACK	2B	CB2B	0.75
TB2C	1	8642559-1	75	250MCM	BLACK	2C	CB2C	0.75
TB2N	1	8642559-1	75	250MCM	BLACK	2N	NEUT	0.75
TB2G	1	8642402-1	75	2 AWG	GREEN	2G	GRND	0.75
J3A	0.5	8642402-1	34	2	BLACK	3A	CB3A	0.75
J3B	0.5	8642402-1	34	2	RED	3B	CB3B	0.75
J3C	0.5	8642402-1	34	2	BLUE	3C	CB3C	0.75
J3N	0.5	8642402-1	52	2	WHITE	3N	NEUT	0.75
J3G1	0.5	8642402-8	29	8	GREEN	3G	GRND	0.75
J3G2	0.5	8642402-8	29	8	GREEN	3G	GRND	0.75
J3G3	0.5	8642402-8	29	8	GREEN	3G	GRND	0.75
J3G4	0.5	8642402-8	29	8	GREEN	3G	GRND	0.75
J4A	0.5	8642402-1	34	2	BLACK	4A	CB4A	0.75
J4B	0.5	8642402-1	34	2	RED	4B	CB4B	0.75
J4C	0.5	8642402-1	34	2	BLUE	4C	CB4C	0.75
J4N	0.5	8642402-1	28	2	WHITE	4N	NEUT	0.75
J4G1	0.5	8642402-8	46	8	GREEN	4G	GRND	0.75
J4G2	0.5	8642402-8	46	8	GREEN	4G	GRND	0.75
J4G3	0.5	8642402-8	46	8	GREEN	4G	GRND	0.75
J4G4	0.5	8642402-8	46	8	GREEN	4G	GRND	0.75
J5A	0.5	8642402-1	34	2	BLACK	5A	CB5A	0.75
J5B	0.5	8642402-1	34	2	RED	5B	CBSB	0.75
J5C	0.5	8642402-1	34	2	BLUE	5C	CB5C	0.75
J5N	0.5	8642402-1	54	2	WHITE	5N	NEUT	0.75
J5G1	0.5	8642402-8	32	8	GREEN	5G	GRND	0.75
J5G2	0.5	8642402-8	32	8	GREEN	5G	GRND	0.75
J5G3	0.5	8642402-8	32	8	GREEN	SG	GRND	0.75
J5G4	0.5	8642402-8	32	8	GREEN	SG	GRND	0.75

Table 4-6. Power Distribution Panel Wire List

FROM	STRIP LENGTH (IN.)		WIRE LENGTH (IN)	WIRE SIZE (AWG)	WIRE COLOR	WIRE MARKING	TO	STRIP LENGTH (IN.)
J6A	0.5	8642402-1	34	2	BLACK	6A	CB6A	0.75
J6B	0.5	8642402-1	34	2	RED	6B	CB6B	0.75
J6C	0.5	8642402-1	34	2	BLUE	6C	CB6C	0.75
J6N	0.5	8642402-1	31	2	WHITE	6N	NEUT	0.75
J6G1	0.5	8642402-8	50	8	GREEN	6G	GRND	0.75
J6G2	0.5	8642402-8	50	8	GREEN	6G	GRND	0.75
J6G3	0.5	8642402-8	50	8	GREEN	6G	GRND	0.75
J6G4	0.5	8642402-8	50	8	GREEN	6G	GRND	0.75
J7A	0.5	8642402-3	38	6	BLACK	7A	CB7A	0.75
J7B	0.5	8642402-4	38	6	RED	7B	CB7B	0.75
J7C	0.5	8642402-5	38	6	BLUE	7C	CB7C	0.75
J7N	0.5	8642402-6	50	6	WHITE	7N	NEUT	0.75
J7G	0.5	8642402-7	40	6	GREEN	7G	GRND	0.75
J8A	0.5	8642402-3	38	6	BLACK	8A	CB8A	0.75
J8B	0.5	8642402-4	38	6	RED	8B	CB8B	0.75
J8C	0.5	8642402-5	38	6	BLUE	8C	CB8C	0.75
J8N	0.5	8642402-6	40	6	WHITE	8N	NEUT	0.75
J8G	0.5	8642402-7	52	6	GREEN	8G	GRND	0.75
J9A	0.5	8642402-3	33	6	BLACK	9A	CB9A	0.75
J9B	0.5	8642402-4	33	6	RED	9B	CB9B	0.75
J9C	0.5	8642402-5	33	6	BLUE	9C	CB9C	0.75
J9N	0.5	8642402-6	54	6	WHITE	9N	NEUT	0.75
J9G	0.5	8642402-7	44	6	GREEN	9G	GRND	0.75
J10A	0.5	8642402-3	34	6	BLACK	10A	CB10A	0.75
J10B	0.5	8642402-4	34	6	RED	10B	CB10B	0.75
J10C	0.5	8642402-5	34	6	BLUE	10C	CB10C	0.75
J10N	0.5	8642402-6	44	6	WHITE	10N	NEUT	0.75
J10G	0.5	8642402-7	52	6	GREEN	10G	GRND	0.75
J11A	0.5	8642402-3	33	6	BLACK	11A	CB11A	0.75
J11B	0.5	8642402-4	33	6	RED	11B	CB11B	0.75
J11C	0.5	8642402-5	33	6	BLUE	11C	CB11C	0.75
J11N	0.5	8642402-6	58	6	WHITE	11N	NEUT	0.75
J11G	0.5	8642402-7	48	6	GREEN	11G	GRND	0.75

Table 4-6. Power Distribution Panel Wire List

FROM	STRIP LENGTH (IN.)		WIRE LENGTH (IN)	WIRE SIZE (AWG)	WIRE COLOR	WIRE MARKING	TO	STRIP LENGTH (IN.)
J12A	0.5	8642402-3	33	6	BLACK	12A	CB12A	0.75
J12B	0.5	8642402-4	33	6	RED	12B	CB12B	0.75
J12C	0.5	8642402-5	33	6	BLUE	12C	CB12C	0.75
J12N	0.5	8642402-6	48	6	WHITE	12N	NEUT	0.75
J12G	0.5	8642402-7	56	6	GREEN	12G	GRND	0.75
J13A	0.5	8642402-3	33	6	BLACK	13A	CB13A	0.75
J13B	0.5	8642402-4	33	6	RED	13B	CB13B	0.75
J13C	0.5	8642402-5	33	6	BLUE	13C	CB13C	0.75
J13N	0.5	8642402-6	66	6	WHITE	13N	NEUT	0.75
J13G	0.5	8642402-7	54	6	GREEN	13G	GRND	0.75
J14A	0.5	8642402-3	33	6	BLACK	14A	CB14A	0.75
J14B	0.5	8642402-4	33	6	RED	14B	CB14B	0.75
J14C	0.5	8642402-5	33	6	BLUE	14C	CB14C	0.75
J14N	0.5	8642402-6	54	6	WHITE	14N	NEUT	0.75
J14G	0.5	8642402-7	62	6	GREEN	14G	GRND	0.75
J15A	0.5	8642402-3	33	6	BLACK	15A	CB15A	0.75
J15B	0.5	8642402-4	33	6	RED	15B	CB15B	0.75
J15C	0.5	8642402-5	33	6	BLUE	15C	CB15C	0.75
J15N	0.5	8642402-6	66	6	WHITE	15N	NEUT	0.75
J15G	0.5	8642402-7	60	6	GREEN	15G	GRND	0.75
J16A	0.5	8642402-3	33	6	BLACK	16A	CB16A	0.75
J16B	0.5	8642402-4	33	6	RED	16B	CB16B	0.75
J16C	0.5	8642402-5	33	6	BLUE	16C	CB16C	0.75
J16N	0.5	8642402-6	58	6	WHITE	16N	NEUT	0.75
J16G	0.5	8642402-7	70	6	GREEN	16G	GRND	0.75
BUS A	0.5	8642402-14	36	18	BLACK	AIDS1 -1	DS1 -1	0.5
BUS B	0.5	8642402-15	36	18	RED	B/DS2-1	DS2-1	0.5
BUS C	0.5	8642402-16	36	18	BLUE	C/DS3-1	DS3-1	0.5
DS1-2	0.5	8642402-17	3	18	WHITE	NONE	DS2-2	0.5
DS2-2	0.5	8642402-17	3	18	WHITE	NONE	DS3-2	0.5
NEUT	0.5	8642402-17	48	18	WHITE	N/DS3-2	DS3-2	0.5
GRND (BUS)	0.5	8642402-11	20	2	GREEN	NONE	GRND	0.5 (LUG)

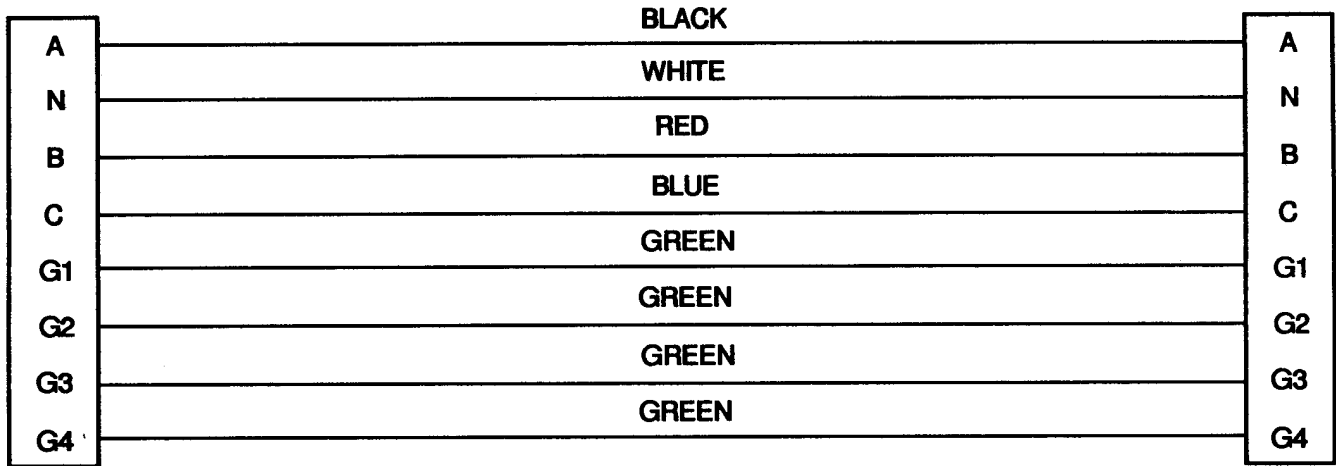

100-AMP, 8-WIRE POWER CABLE

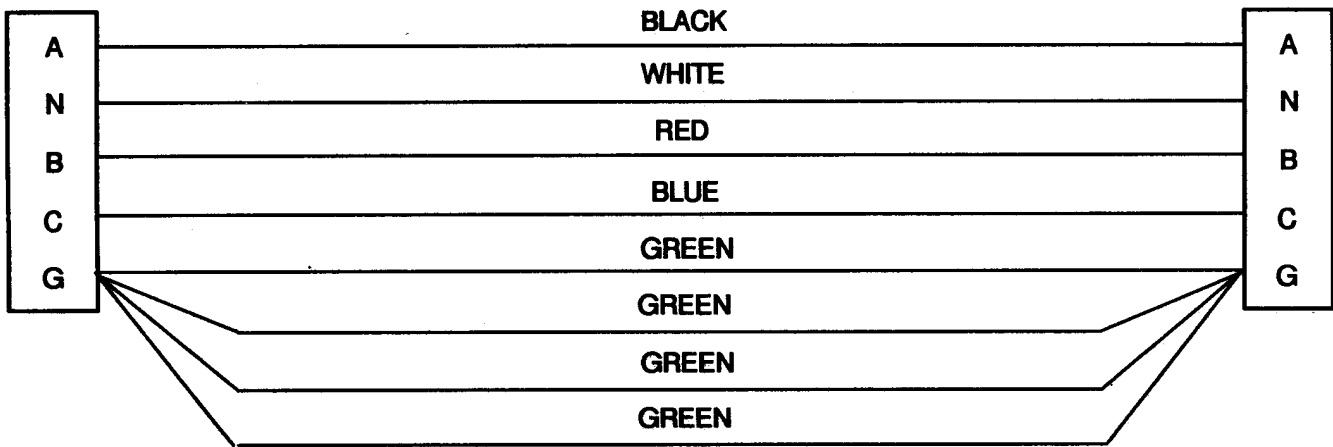

60-AMP, 5-WIRE POWER CABLE

Figure 4-1. Power Cable Wiring Diagrams.

## SECTION V. UNIT MAINTENANCE PROCEDURES

---

**4.12 TOP COVER ASSEMBLY.**

---

This task covers: a. Removal                      b. Installation

---

**INITIAL SETUP****Tools**

General Mechanics Automotive Tool Kit  
(Item 2, Appendix B).

**Materials/Parts**

Lock Nut (2)

**Personnel Required**

Two.

**Equipment Conditions**

Reference  
Para. 2-5 Equipment shut down.

**General Safety Instructions****WARNING**

High voltage is present in this equipment during operation. Do not attempt making any repairs without first shutting down all input power from the power distribution panel. Failure to observe this warning could result in serious injury or death.

**WARNING**

Top cover must be supported when opened to avoid serious injury to personnel.

---

**REMOVAL**

**CAUTION**

Failure to support the top cover when opened completely could result is damage to the hinges.

- a. Remove two lock nuts (1, Figure 42), screws (2), and restraining cable (3) from top cover assembly (4). Discard lock nuts.
- b. Remove top cover assembly (4) from power distribution panel by sliding off hinge.

---

**4.12 TOP COVER ASSEMBLY.**

---

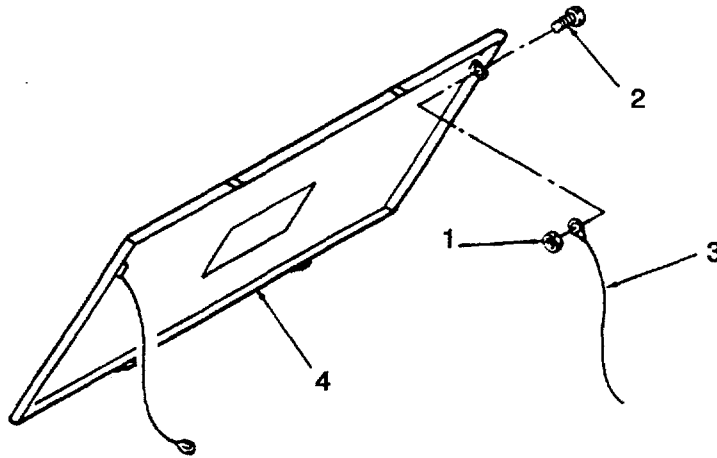

Figure 4-2. Top Cover Assembly.

---

**INSTALLATION**

- a. Install top cover assembly (4) on hinge on power distribution panel.
- b. Install two restraining cables (3) on top cover assembly and secure with two screws (4) and new lock nuts (1).

---

**4.13 DEADFRONT PANEL ASSEMBLY AND TOP COVER RESTRAINING CABLES.**

---

This task covers: a. Removal                      b. Installation

---

**INITIAL SETUP****Tools**

General Mechanics Automotive Tool Kit  
(Item 2, Appendix B).

**Equipment Conditions**

Reference  
Para. 2-5 Equipment shut down.  
Para 4.12 Top cover assembly removed.

**Materials/Parts**

Tags (Item 14, Appendix E).

**General Safety Instructions****WARNING**

High voltage is present in this equipment during operation. Do not attempt making any repairs without first shutting down all input power from the power distribution panel. Failure to observe this warning could result in serious injury or death.

---

**Personnel Required**

Two.

---

**REMOVAL**

- a. Remove sixteen nuts (1, Figure 43) and screws (10) and remove deadfront panel assembly (6).
- b. Remove two lock nuts (7), screws (4) and restraining cables (5).
- c. Remove two nuts (9), star washers (8), screw (3) and fuse clips (2).

---

**INSTALLATION**

- a. Install two fuse clips (2), screws (3), star washer (8) and nut (9).
- b. Torque screws (3) per Appendix H.
- c. Install two restraining cables (5) and secure with two screws (4) and nuts (7). Tighten nuts.
- d. Install deadfront panel assembly (6), sixteen screws (10), and nuts (1). Tighten nuts.

4.13 DEADFRONT PANEL ASSEMBLY AND TOP COVER RESTRAINING CABLES - CONTINUED..

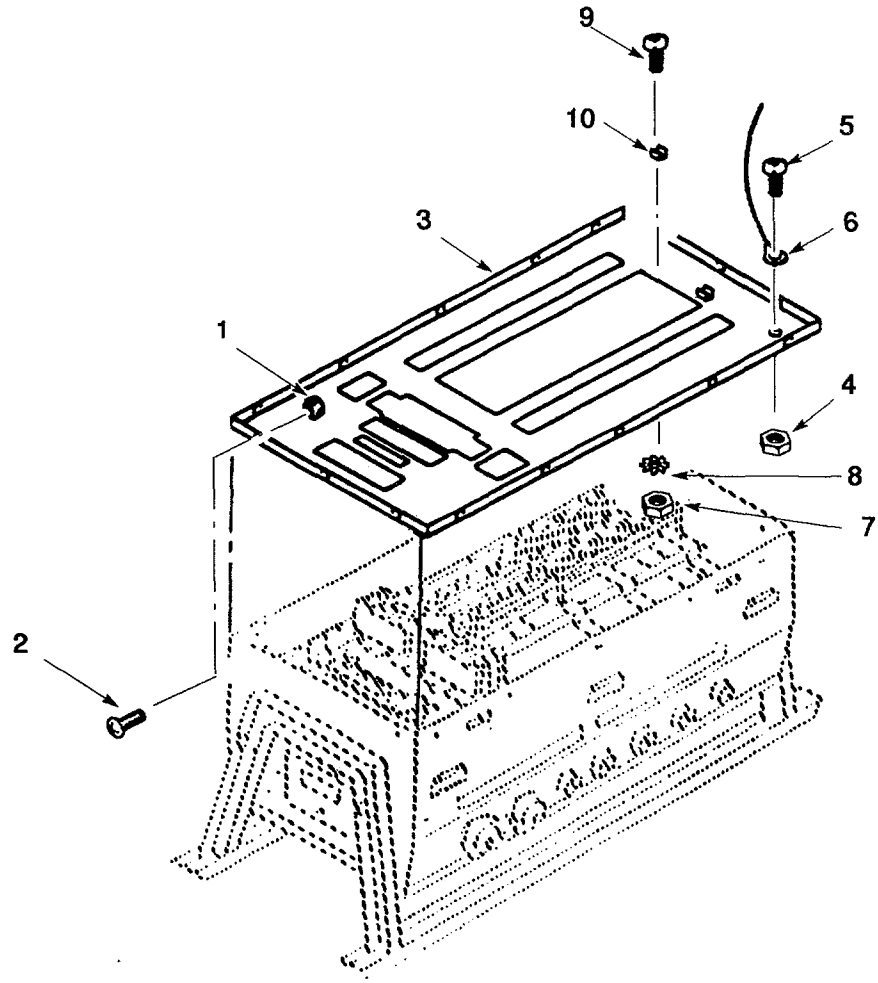

Figure 4-3. Top Cover Assembly.



**SECTION V. UNIT MAINTENANCE PROCEDURES**

---

**4.14 SUB PANEL.**

---

This task covers: a. Removal                      b. Installation

---

**INITIAL SETUP****Tools**

General Mechanics Automotive Tool Kit  
(Item 2, Appendix B).

**Materials/Parts**

Tags (Item 14, Appendix E).

**Personnel Required**

One.

**Equipment Conditions**

Reference  
Para 2.5 Equipment shut down.  
Para 4.13 Deadfront panel assembly removed.

---

**REMOVAL**

- a. Remove six screws (1, Figure 4-4) and remove panel (2).
- b. Tag and disconnect electrical leads.
- c. Remove edge trim (3) if damaged.

**INSTALLATION**

- a. Install edge trim (3) if removed.
- b. Connect electrical leads and remove tags.
- c. Install panel (2) and secure with six screws (1). Tighten screws.

**General Safety Instructions****WARNING**

High voltage is present in this equipment during operation. Do not attempt making any repairs without first shutting down all input power from the power distribution panel. Failure to observe this warning could result in serious injury or death.

4.14 SUB PANEL - CONTINUED.

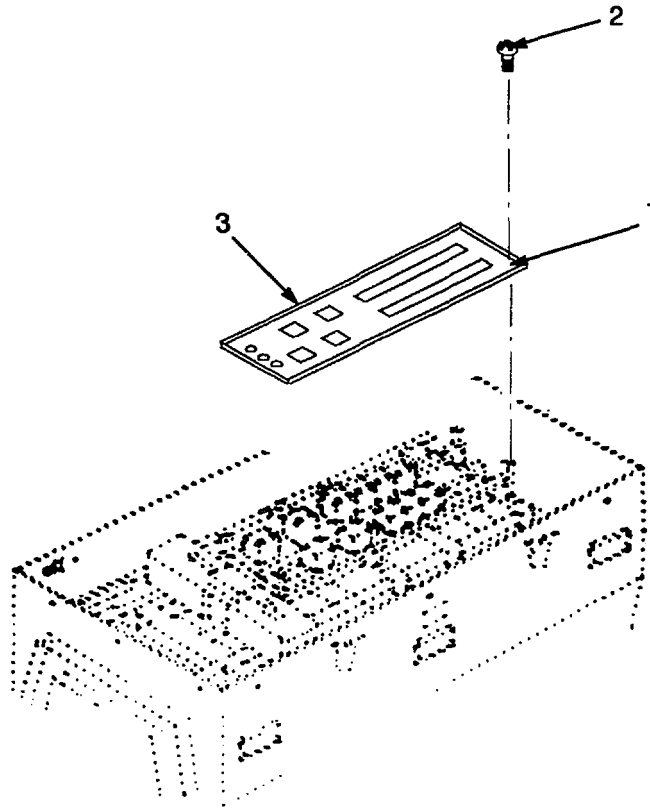

Figure 4-4. Sub Panel.

---

**4.15 INDICATOR LIGHT ASSEMBLY AND INDICATOR LIGHT BULB..**

---

This task covers: a. Removal                      b. Installation

---

**INITIAL SETUP**

**Tools**

General Mechanics Automotive Tool Kit  
 (Item 2, Appendix B).  
 Soldering Iron (Item 7, Appendix B).  
 Heat Gun (Item 8, Appendix B).

**Equipment Conditions**

Reference  
 Para. 2-5 Equipment shut down.  
 Para 4.14 Top cover assembly removed.

**Materials/Parts**

Tags (Item 14, Appendix E).  
 Sleeving (Item 6, Appendix E).  
 Solder (Item 7, Appendix E).  
 Lamp (Item 7, Appendix F, Figure 4).

**WARNING**

High voltage is present in this equipment during operation. Do not attempt making any repairs without first shutting down all input power from the power distribution panel. Failure to observe this warning could result in serious injury or death.

**Personnel Required**

One.

---

**REMOVAL**

a. Indicator light Assembly.

- (1) Cut and remove sleeving (1, Figure 45).
- (2) Tag and identify electrical leads (2).
- (3) Unsolder and remove electrical leads (2) from light assembly.
- (4) Remove lens assembly (3) and lamp (4) from lamp holder (7).
- (5) Remove nut (5), lock washer (6) and lamp holder (7).

---

**4.15 INDICATOR LIGHT ASSEMBLY AND INDICATOR LIGHT BULB-CONTINUED.**

---

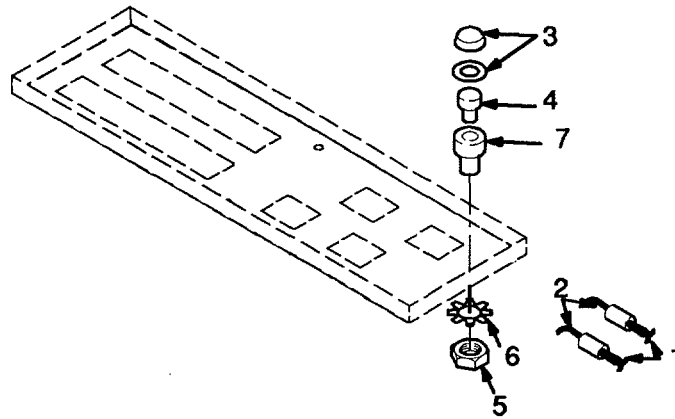

Figure 4-5. Indicator Light Assembly.

---

**INSTALLATION**

- a. Install lamp holder (7) and secure with star washer (6) and nut (5).
- b. Tighten nut.
- c. Install new sleeving (1) on electrical leads (2).
- d. Solder electrical leads (2) to lamp holder (7).
- e. Slide sleeving (1) over solder connections and heat shrink.
- f. Remove tags.
- g. Install lamp (4). and lens assembly (3) into lamp holder (7).

---

**REMOVAL**a. Indicator Light Bulb.

- (1) Open lens assembly (1, Figure 4-6).
- (2) Remove lamp (2) from lamp holder (3).

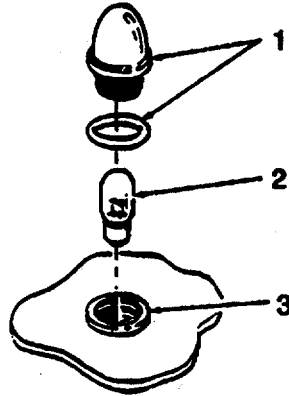

Figure 4-6. Indicator Light Assembly.

---

**INSTALLATION**

- a. Install lamp (2) in lamp holder (3)
- b. Install lens assembly (1) into lamp holder (3).

---

**4.16 60 AND 100 AMP CIRCUIT BREAKERS.**

---

This task covers:      a. Test                      b. Removal                      c. Installation

---

**INITIAL SETUP**
**Tools**

Multimeter Digital (Item 1, Appendix B).  
 General Mechanic's Automotive Tool Kit  
 (Item 2, Appendix B).  
 Torque Wrench, (Item 6, Appendix B).

**Equipment Conditions**

Reference  
 Para. 2-5 Equipment shut down.  
 Para 4.14 Sub panel removed.

**Materials/Parts**

Tags (Item 14, Appendix E).

**WARNING**

High voltage is present in this equipment during operation. Do not attempt making any repairs without first shutting down all input power from the power distribution panel. Failure to observe this warning could result in serious injury or death.

**Personnel Required**

One.

---

**TESTING**

- a. Place circuit breaker to dosed (ON) position.
- b. Preset multimeter (1, Figure 4-7) for continuity testing and touch one probe (2) to input terminal (3) of circuit breaker and touch remaining probe (5) to associated output terminal (4). Continuity must be present.
- c. Repeat step b on the two remaining pairs of input/output terminals.

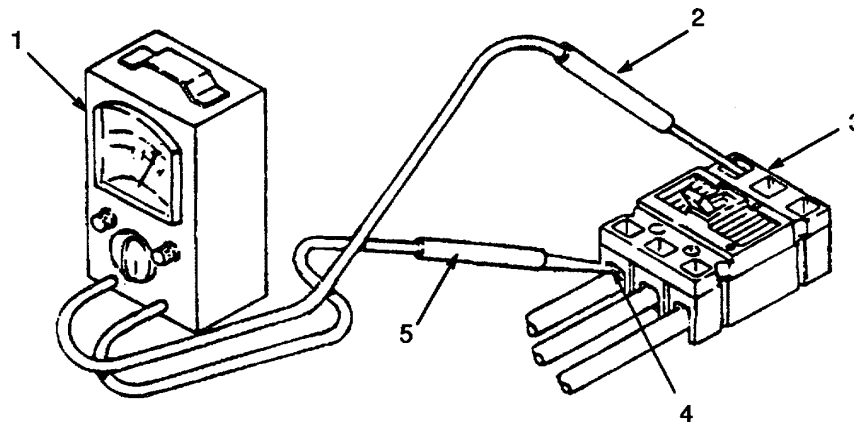

Figure 4-7. Circuit Breaker Test.

REMOVAL

- a. 100 Amp Circuit Breaker.
  - (1) Tag and identify leads.
  - (2) Loosen three screws (1, Figure 4-8) and remove leads.
  - (3) Remove three screws (2).
  - (4) Raise circuit breaker (3) approximately 35 degree angle and remove from under breaker mounting rail (7).
  - (5) Remove three remaining circuit breakers, repeat steps a (1) through (4) above.

INSTALLATION

- a. Hold circuit breaker (3) at approximately 35 degrees angle and install to under breaker mounting rail (7).
- b. Install three screws (2). Tighten screws.
- c. Install three leads and tighten screws. Remove tags.
- d. Install three remaining circuit breakers, repeat steps a through c, above.

4.16 60 AND 100 AMP CIRCUIT BREAKERS - CONTINUED.

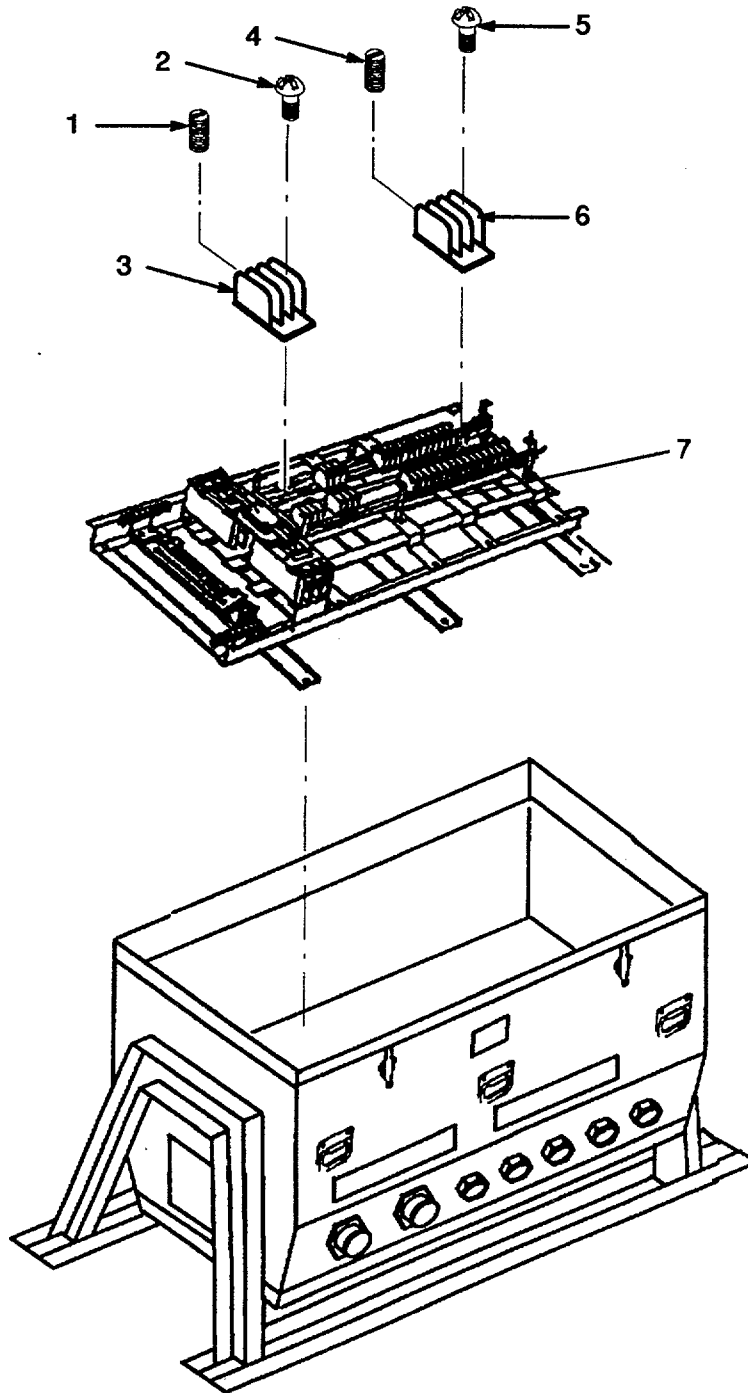

Figure 4-8. Circuit Breaker Removal.



REMOVAL

a. 60 Amp Circuit Breaker.

- (1) Tag and identify leads.
- (2) Loosen three screws (4, Figure 4-8) and remove leads.
- (3) Remove three screws (4).
- (4) Raise circuit breaker (6) approximately 35 degree angle and remove from under breaker mounting rail (7).
- (5) Remove nine remaining circuit breakers, repeat steps (1) through (4), above.

INSTALLATION

- a. Hold circuit breaker (6) at 35 approximately degree angle and install to under breaker mounting rail (7).
- b. Install three screws (4). Tighten screws.
- c. Install three leads and tighten screws (4). Remove tags.
- d. Install three remaining circuit breakers, repeat steps a through c above.

---

**4.17 TERMINAL BLOCKS.**

---

This task covers:      a. Test      b. Removal

---

**INITIAL SETUP****Tools**

General Mechanic's Automotive Tool Kit  
(Item 2, Appendix B).

**Equipment Conditions**

Reference  
Para. 2-5 Equipment shut down.

**Materials/Parts**

Tags (Item 14, Appendix E).  
Lock Washers (Items 4, 7, and 10, Appendix F,  
Figure 6).

**WARNING**

High voltage is present in this equipment during operation. Do not attempt making any repairs without first shutting down all input power from the power distribution panel. Failure to observe this warning could result in serious injury or death.

**Personnel Required**

Two

---

**REMOVAL**

- a. Unlock latch (1, Figure 49) and remove access door (2) by sliding off hinge.
- b. Tag and identify, five electrical leads (3).
- c. Loosen five set screws (5) and disconnect electrical leads (3).
- d. Remove six screws (7), lock washers (6), and terminal block (4). Discard lock washers.
- e. Remove two screws (10), lock washers (9), and terminal block (8). Discard lock washers.

**NOTE**

Terminal blocks at each end are removed the same way.

- f. Remove screw (11) and lock washer (12), and ground terminal block (13). Discard lock washer.

**INSTALLATION**

- a. Install ground terminal block (13), new lock washer (12), and screw (11). Tighten screw.
- b. Install terminal block (8), two new lock washers (9), and screws (10). Tighten screws.
- c. Install terminal block (4), six new lock washers (6), and screws (7). Tighten screws.

- d. Install five electrical leads (3) and torque set screws (5) in accordance with Appendix H.
- e. Remove tags.
- f. Install access door (2) by sliding onto hinge. Lock latch (1).

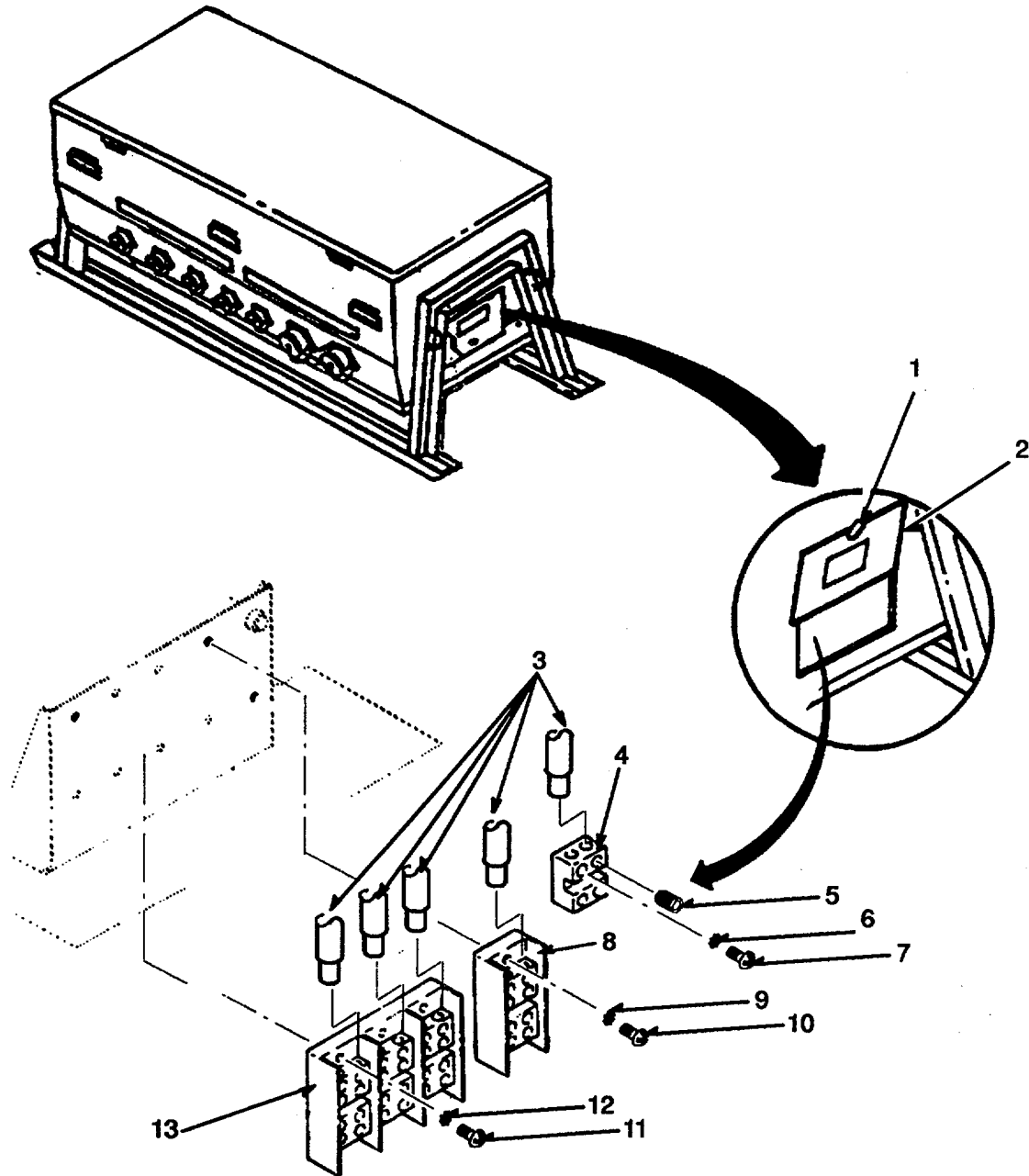

Figure 4-9. Terminal Block Removal.

---

#### 4.18 FUSE HODER AND FUSE.

---

This task covers:      a. Test      b. Removal

---

#### INITIAL SETUP

##### Tools

General Mechanic's Automotive Tool Kit  
(Item 2, Appendix B).

##### Equipment Conditions

Para 2.5 Equipment shut down.  
Para. 4.13 Deadfront panel assembly removed.

##### Materials/Parts

Tags (Item 14, Appendix E).  
Sleeving (Item 6, Appendix E)  
Solder (Item 7, Appendix E).  
Fuse (Item 8, Appendix F, Figure 6).

##### **WARNING**

High voltage is present in this equipment during operation. Do not attempt making any repairs without first shutting down all input power from the power distribution panel. Failure to observe this warning could result in serious injury or death.

##### Personnel Required

One.

---

#### REMOVAL

- a. Unlock latch (1, Figure 4-10) and remove access door (2) by sliding off hinge.
- b. Tag and identify electrical leads.
- c. Cut sleeving and unsolder electrical leads.
- d. Remove fuse cap (3) and fuse (4).
- e. Remove nut (5) from body of fuse holder (6).
- f. Remove fuse holder (6) and gasket (7) from bracket (8)

#### INSTALLATION

- a. Install gasket (7) and fuse holder (6) in bracket (8).
- b. Install nut (5) on fuse holder (6). Tighten nut.
- c. Install sleeving on electrical leads.
- d. Solder leads on fuse holder (6).
- e. Slide sleeving over solder connections and heat shrink. Remove tags.

- f. Install fuse (4) and fuse cap (3).
- g. Install access door (2) and lock latch (1).

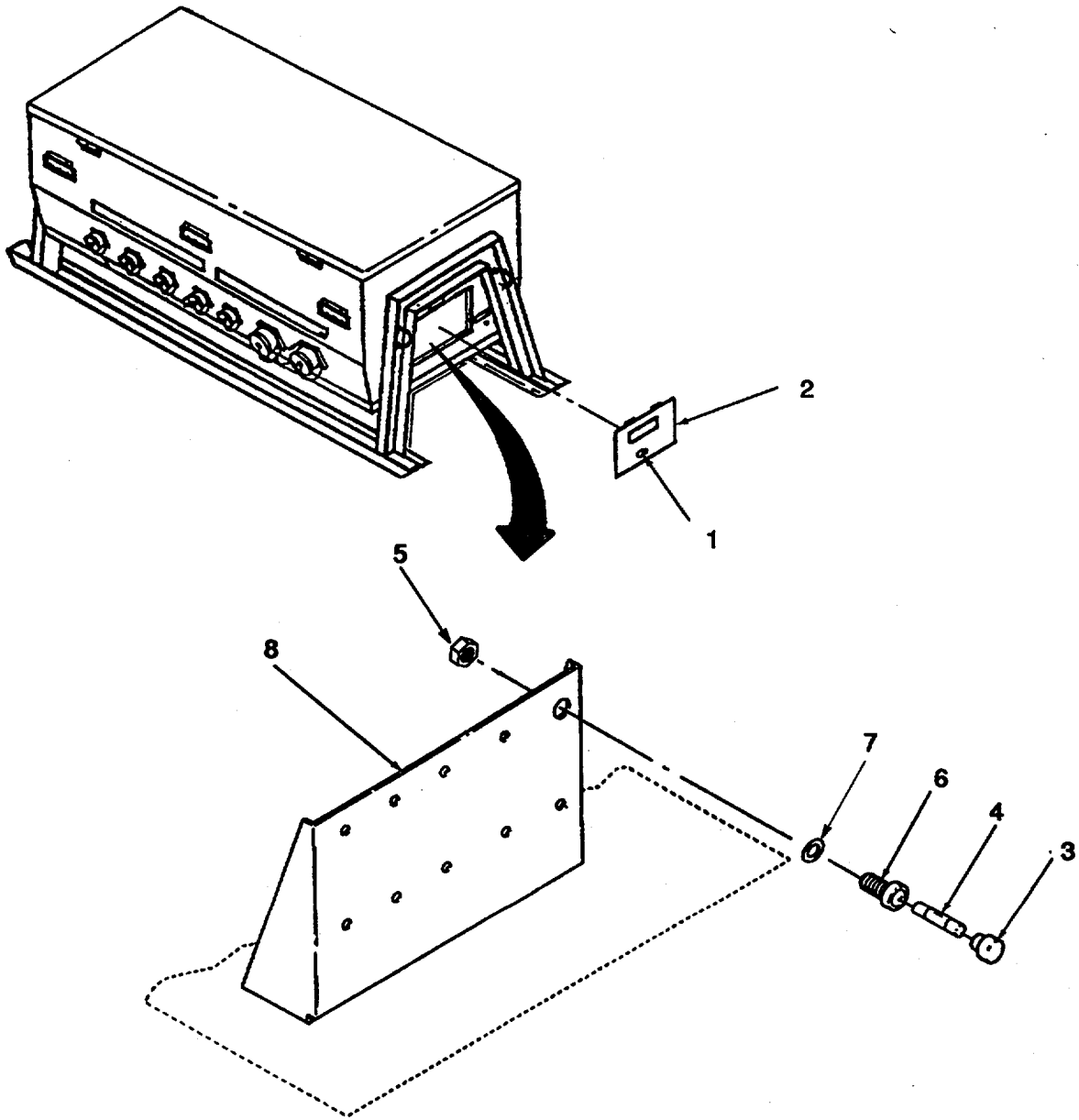

Figure 4-10. Fuse/Fuse Holder Removal.

---

**4.19 INTERLOCK SOLENOID.**

---

This task covers:      a. Test      b. Removal

---

**INITIAL SETUP****Tools**

General Mechanic's Automotive Tool Kit  
(Item 2, Appendix B).  
Soldering Iron (Item 7, Appendix B).  
Heat Gun (Item 8, Appendix B).

**Materials/Parts**

Tags (Item 14, Appendix E).  
Sleeving (Item 6, Appendix E)  
Solder (Item 7, Appendix E).  
Tiedown strap (Item 4, Appendix F, Figure 7).

**Personnel Required**

One.

---

**REMOVAL**

- a. Unlock latch (1, Figure 4-11) and remove access door (2) by sliding off of hinge.
- b. Tag and identify electrical leads of solenoid interlock
- c. Disconnect leads from terminal block
- d. Cut sleeving and unsolder leads from fuse holder.
- e. Cut and remove tie down strap.
- f. Remove two screws (3) and solenoid (4).

**INSTALLATION**

- a. Install solenoid (4) and secure with two screws (3). Tighten screws.
- b. Tag and identify electrical leads.
- c. Solder lead to fuse holder.
- d. Slide sleeving over solder and heat shrink

**Equipment Conditions**

Reference  
Para. 2.5 Equipment shut down.

**WARNING**

High voltage is present in this equipment during operation. Do not attempt making any repairs without first shutting down all input power from the power distribution panel. Failure to observe this warning could result in serious injury or death.

- e. Feed tiedown strap through cable tie holder (5) and secure solenoid leads.

**NOTE**

Ensure all leads are securely fastened.

- f. Connect lead to terminal block Remove tags.
- g. Install access cover (2) by sliding onto hinge and lock latch (1).

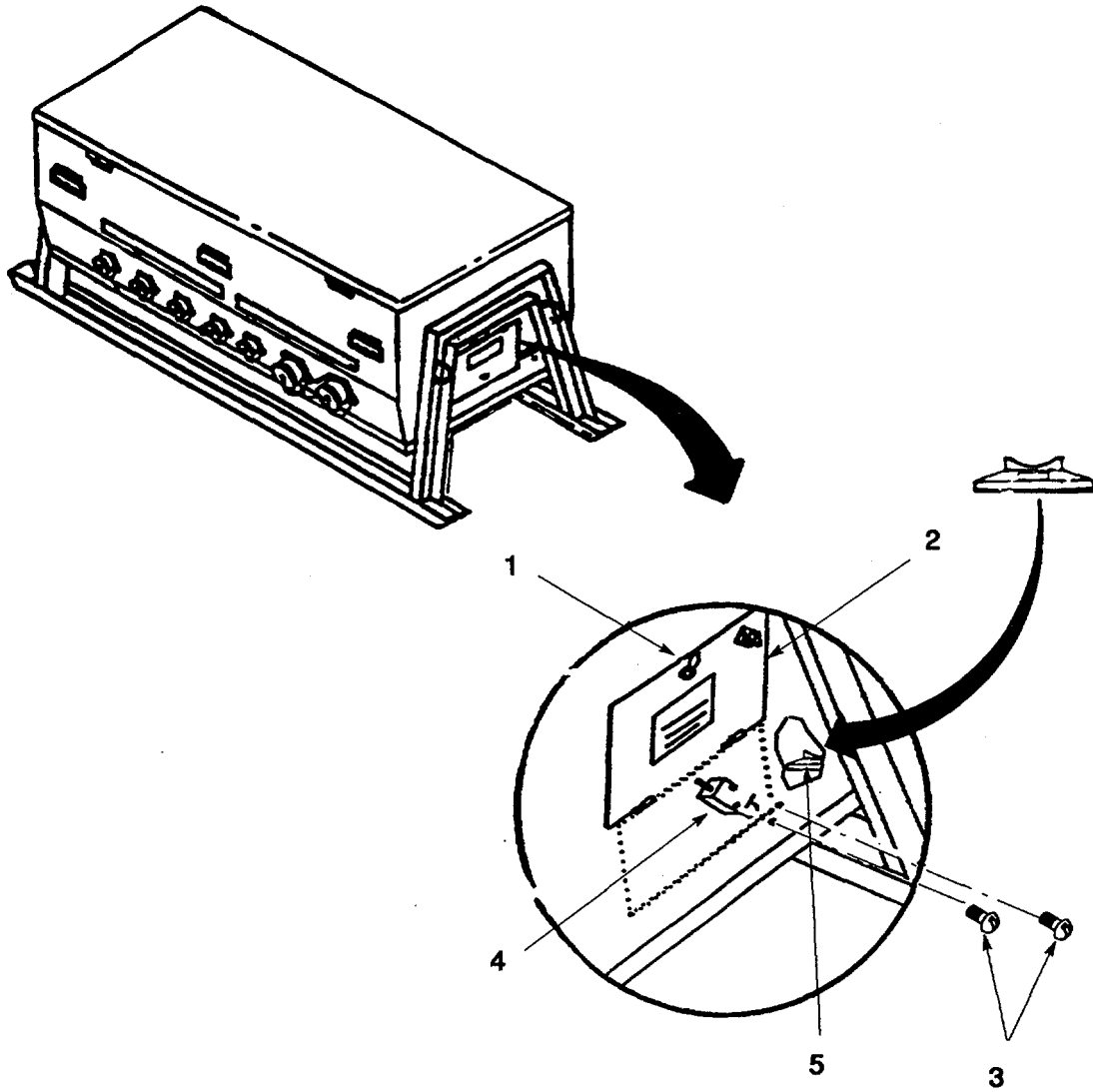

Figure 4-11. Interlock Solenoid.

---

**4.20 MS CONNECTORS.**

---

This task covers:      a. Test                      b. Removal                      c. Installation

---

**INITIAL SETUP**

**Tools**

Multimeter Digital (Item 1, Appendix B).  
 General Mechanic's Automotive Tool Kit  
 (Item 2, Appendix B).  
 Torque Wrench, (Item 6, Appendix B).

**Equipment Conditions**

Reference  
 Para. 2-5 Equipment shut down.  
 Para 4.14 Sub panel removed.

**Materials/Parts**

Tags (Item 14, Appendix E).  
 Gasket (Item 9, Appendix F, Figure B).

**WARNING**

High voltage is present in this equipment during operation. Do not attempt making any repairs without first shutting down all input power from the power distribution panel. Failure to observe this warning could result in serious injury or death.

**Personnel Required**

One.

---

**TEST**

- a. Remove cover (1, Figure 4-12) from connector (2).
- b. Preset multimeter (3) to perform continuity testing.
- c. Touch one probe (4) of multimeter to bus bar (5) designated NEUTRAL.

**NOTE**

To determine paths of continuity, refer to Table 4-4.

- d. Touch remaining probe (6) to all contacts in connector (2).
- e. Repeat steps c and d for bus bar designated GRD.
- f. Touch probe (4) to phase A output terminal (7) on associated circuit breaker (8).
- g. Touch probe (6) to all contacts in connector (2). Continuity should be as specified in Table 44.
- h. Repeat steps f and g for phase B and phase C circuit breaker output terminals.

**NOTE**

If any deficiencies are discovered or isolated during continuity test, replace connector (2).

- i. Screw cover (1) onto connector (2).



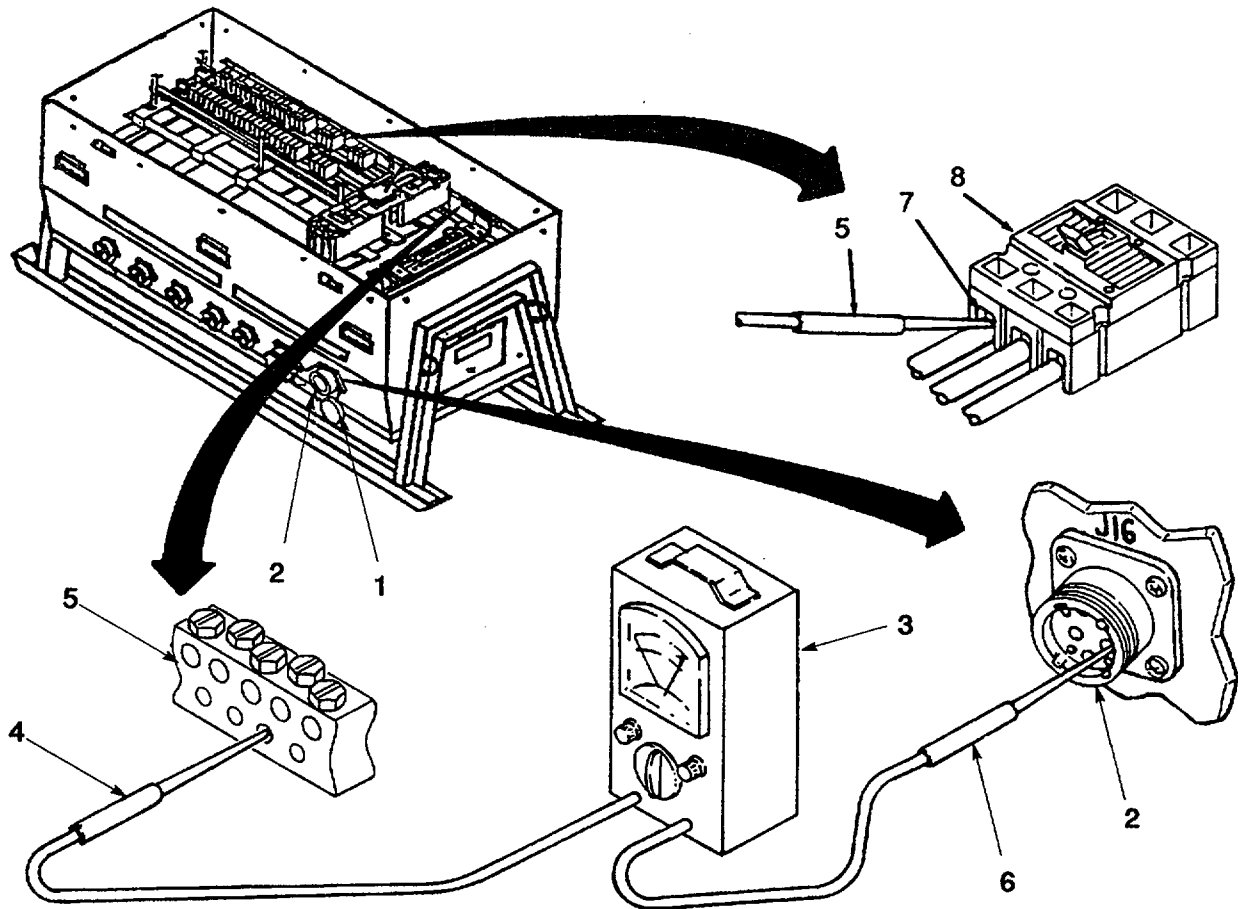

Figure 4-12. MS Connectors.

## REMOVAL

### NOTE

The 60-amp and 100- amp connectors differ only in number of wires and relative sizes. There are fourteen connectors on the power distribution panel and this procedure is typical for all.

- a. Loosen socket-head screw on each output terminal (1, Figure 413) of corresponding circuit breaker (2).
- b. Tag and remove three connection wires (3).
- c. Remove screws (4) securing neutral and ground wires from connector to associated bus bars (5) and remove wires (6).

4.20 MS CONNECTORS - CONTINUED.

- d. Remove cover (7) from connector.
- e. Remove four screws (8), lock washers (9) and cover (7) with chain.
- f. Remove connector (10) and discard gasket (11) from power distribution panel enclosure (12).

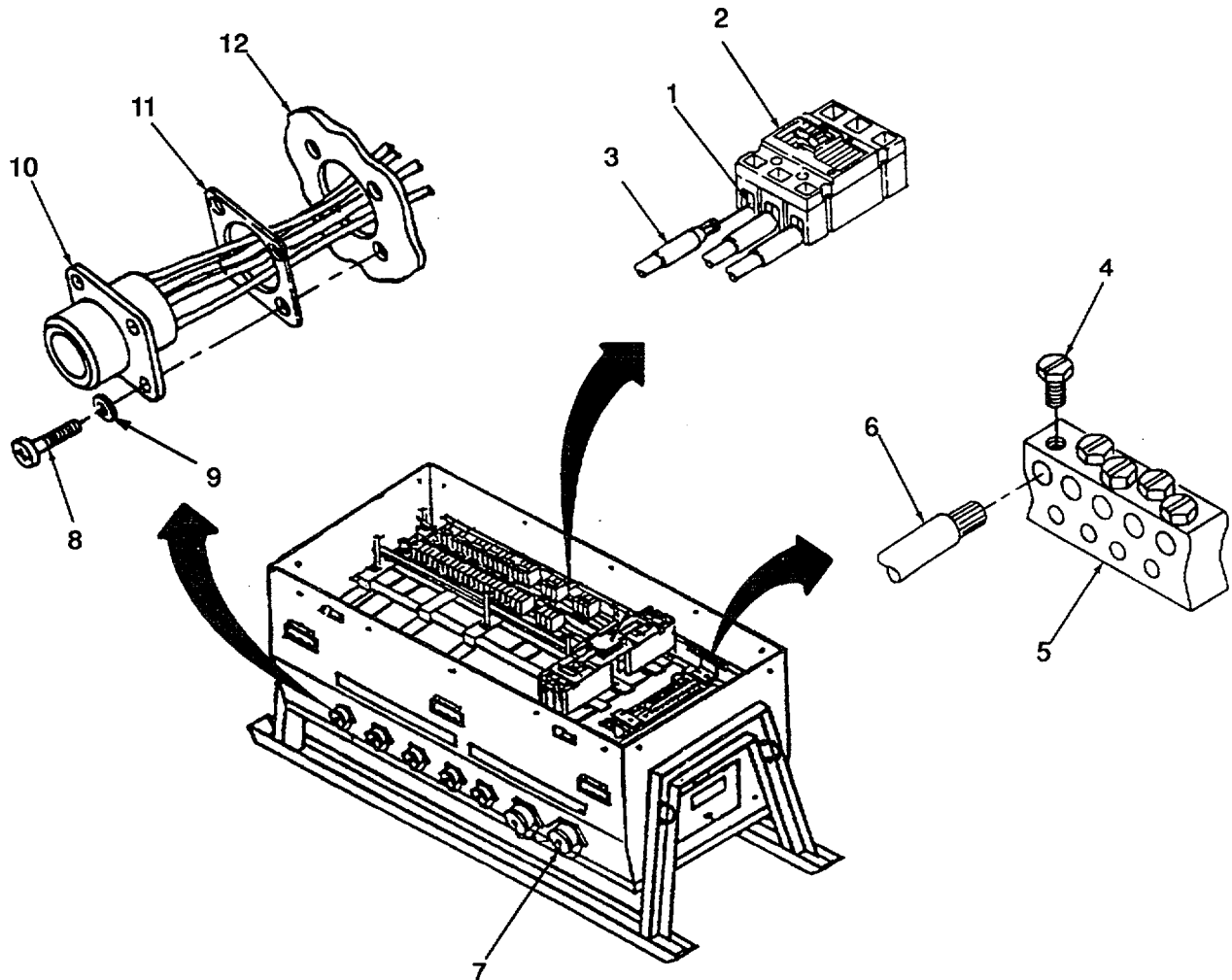

Figure 4-13. MS Connectors.

---

**INSTALLATION**

---

- a. Position connector (10) and new gasket (11) in opening on power distribution panel enclosure (12).
- b. Position connector cover chain under lower-left hand screw. Install four screws (8) and lock washers (9). Tighten screws.
- c. Install cover (7) on connector (10).
- d. Position connector neutral and ground wires (6) on associated bus bars (5) and install screws (4).
- e. Install three connector wires (3) in output terminals (1) of associated circuit breaker (2) with phase markings matching wires on input terminals.
- f. Torque screws to 275 in.-lb (31.4 Nm) for 400-amp circuit breaker and 45 in.-lb (5.1 Nm) for 60 and 100-amp circuit breakers.
- g. Remove tags.

---

## 4.21 CABLE ASSEMBLIES.

---

This task covers: Testing

---

### INITIAL SETUP

#### Tools

Multimeter, Digital (Item 1, Appendix B).

#### Personnel Required

One

#### Equipment Conditions

Reference  
 Para 2.5 Equipment shut down.  
 Para 4.14 Sub panel removed.

---

#### General Safety Instructions

#### **WARNING**

High voltage is present in this equipment during operation. Do not attempt making any repairs without first shutting down all input power from the power distribution panel. Failure to observe this warning could result in serious injury or death.

#### **NOTE**

Both internal and external cables associated with the power distribution panel are tested using a multimeter to verify continuity

---

### TESTING

---

#### a. Internal Cable Assembly.

- (1) Preset multimeter (1, Figure 4-14) to perform continuity testing.
- (2) Touch probes (2) of multimeter to each end of cable (3), refer to power distribution panel wiring diagram (FO-1) and Table 4-4. Multimeter should indicate continuity.

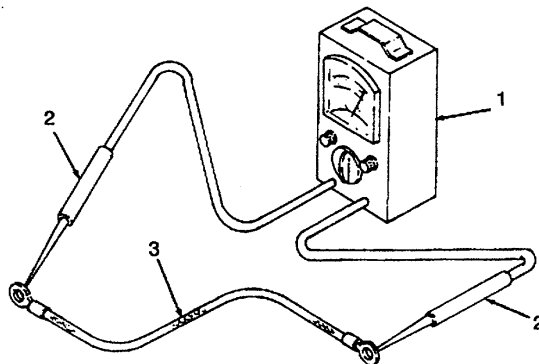
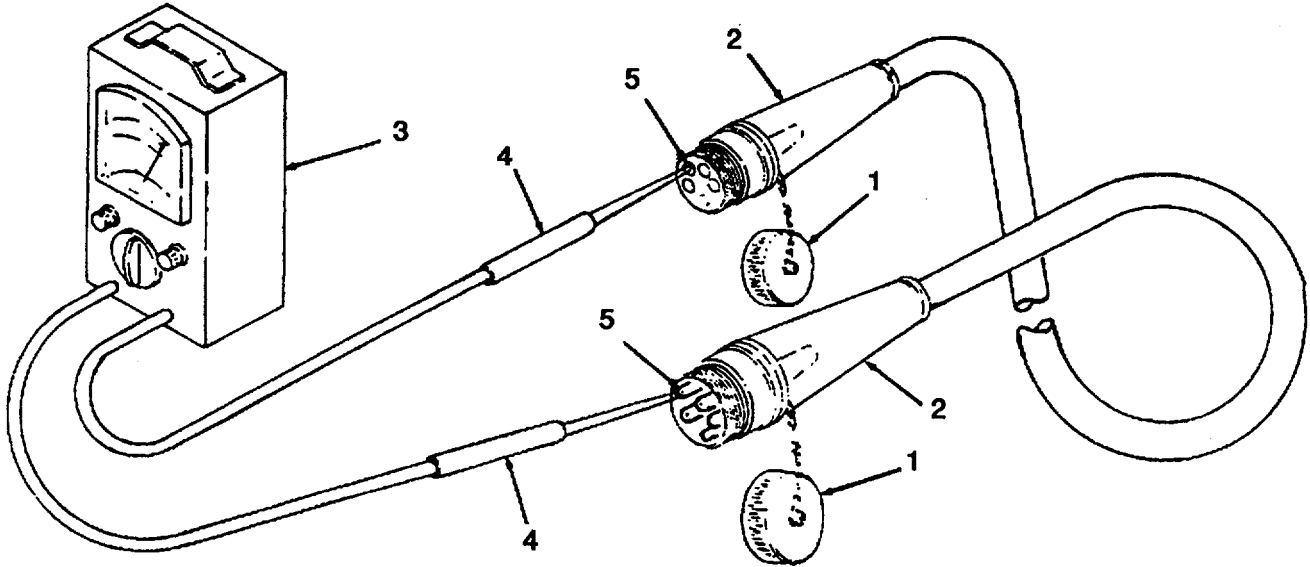

Figure 4-14. Internal Cable Assembly.

b. External Cable Assembly.

- (1) Unscrew and remove covers (1, Figure 4-15) from cable connectors (2).
- (2) Preset multimeter (3) to perform continuity testing.
- (3) Refer to power cable wiring diagram (Figure 4-1) and Table 4-4. Touch probes (4) of multimeter to each pair of contacts (5) as shown in Table 4-4. Continuity should be as specified in Table 4-4.
- (4) Install covers (1) on cable connectors (2).



**Figure 4-15. External Cable Assembly.**

**SECTION VI. PREPARATION FOR STORAGE OR SHIPMENT****4.22 PREPARATION FOR STORAGE OR SHIPMENT.**

4.22.1 Administrative Storage. Placement of equipment in administrative storage should be for short periods of time when a shortage of maintenance effort exists. Items should be in mission readiness within 24 hours or within the time factors as determined by the directing authority. During the storage period, appropriate maintenance records will be kept.

4.22.2 Before Storage Activities. Before placing equipment in administrative storage, current maintenance services and Preventive Maintenance Checks and Services (PMCS) should be completed, shortcomings and deficiencies should be corrected, and all modification work orders (MWOs) should be applied.

4.22.3 Storage Site Selection. Inside storage is preferred for items selected for administrative storage. If inside storage is not available, trucks, vans, CONEX containers, and other containers may be used.

4.22.4 Inspection. Perform preventive maintenance checks and services listed in Table 4-2.

4.22.5 Repair. Correct deficiencies noted during the inspection. Refer repairs beyond the scope of Unit maintenance to Direct Support maintenance personnel.

4.22.6 Cleaning. Refer to operator PMCS (Table 2-1) for cleaning instructions.

4.22.7 Painting.

4.22.7.1 Remove rust, corrosion, and flaked and peeling paint. Ensure surfaces to be painted are dry. Refer to TM 38-230-1, Packaging of Material: Preservation.

4.22.7.2 Mask connectors, data plates, and ground lug that are not to be painted with masking tape (Item 8, Appendix E).

4.22.7.3 Paint surface using paint (Item 4, Appendix E), as required, to protect against deterioration. Refer to TM 43-01 39, Painting Instructions for Field Use.

4.22.8 Packaging. Refer to TM38-230-2, Packaging of Material: Preservation.

## CHAPTER 5

## DIRECT SUPPORT MAINTENANCE INSTRUCTIONS

SECTION I. REPAIR PARTS; TOOLS; SPECIAL TOOLS; TEST,  
MEASUREMENT, AND DIAGNOSTIC EQUIPMENT (TMDE); AND SUPPORT  
EQUIPMENT

**5.1 INTRODUCTION.** Power generator equipment repairer, is authorized to perform all direct support maintenance on the power distribution panel.

**5.2 COMMON TOOLS AND EQUIPMENT.** For authorized common tools and equipment, refer to the Modified Table of Organization and Equipment (MTOE) applicable to your unit.

**5.3 SPECIAL TOOLS, TMDE, AND SUPPORT EQUIPMENT.** Refer to Appendix B, Maintenance Allocation Chart, and Appendix F, Repair Parts and Special Tools List for a list of special tools, TMDE, and support equipment.

**5.4 REPAIR PARTS.** Repair parts and special tools are listed and illustrated in Appendix F.

## SECTION II. DIRECT SUPPORT TROUBLESHOOTING

**5.5 DIRECT SUPPORT TROUBLESHOOTING.**

5.5.1 All troubleshooting for the power distribution panel is accomplished at the operator and unit levels of maintenance by testing as authorized by the Maintenance Allocation Chart in Appendix B.

5.5.2 Keep in mind that this manual addresses only the power distribution panel. Refer to appropriate technical manuals to identify problems caused by the power generation equipment. Refer to TM 9-6150-226-13 for troubleshooting procedures applicable to DISE/PDISE equipment

## SECTION III. DIRECT SUPPORT MAINTENANCE PROCEDURES

## 5.6 TOP COVER ASSEMBLY.

This task covers: Repair

INITIAL SETUPTools

General Mechanic's Automotive Tool Kit  
(Item 2, Appendix B).  
Drill (Item 4, Appendix B).  
Riveter, Blind Head (item 5, Appendix B).

Materials/Parts

Hinges (Item 4, Appendix F).  
Rivets (Item 3, Appendix F).  
Gasket (Item 5, Appendix F).

Personnel Required

Two.

Equipment Conditions

Reference  
Para 4.12 Top cover assembly removed.

General Safety Instructions**WARNING**

High voltage is present in this equipment during operation. Do not attempt making any repairs without first shutting down all input power from the power distribution panel. Failure to observe this warning could result in serious injury or death.

REPAIR

- a. Drill out four rivets (1, Figure 5-1) and remove two keepers (2).
- b. Drill out four rivets (3) and remove two hinges (4). Remove gasket (5) if damaged and discard.

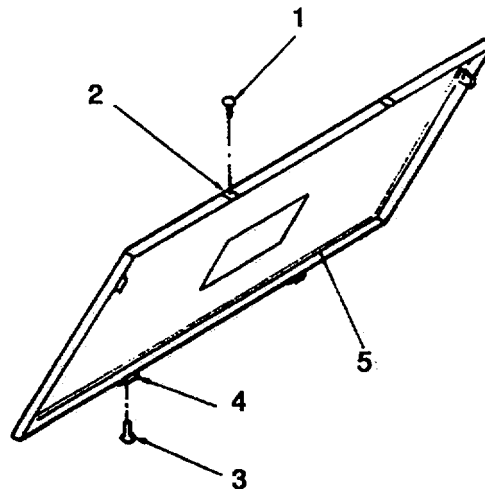

Figure 5-1. Top Cover Assembly.



- c. Hammer out dents; weld, sand, and paint top cover assembly as required. Refer to TM 43-1039 for painting instruction.
- d. Install new gasket (5) if removed.
- e. Install two new hinges (4) and secure with four rivets (3).
- f. Install two keepers (2) and secure with four rivets (1).

---

## 5.7 DEADFRONT PANEL ASSEMBLY.

---

This task covers: Repair

---

### INITIAL SETUP

#### Tools

General Mechanic's Automotive Tool Kit  
(Item 2, Appendix B).

#### Materials/Parts

Paint (Item 4, Appendix E)

#### Personnel Required

One.

#### Equipment Conditions

Reference  
Para 4.14 Deadfront panel assembly removed.

#### General Safety Instructions

##### **WARNING**

High voltage is present in this equipment during operation. Do not attempt making any repairs without first shutting down all input power from the power distribution panel. Failure to observe this warning could result in serious injury or death.

---

### REPAIR

Repair of deadfront panel assembly (1) is limited to pounding out dents, sanding, and painting. Refer to TM 43-0139 for painting instructions.

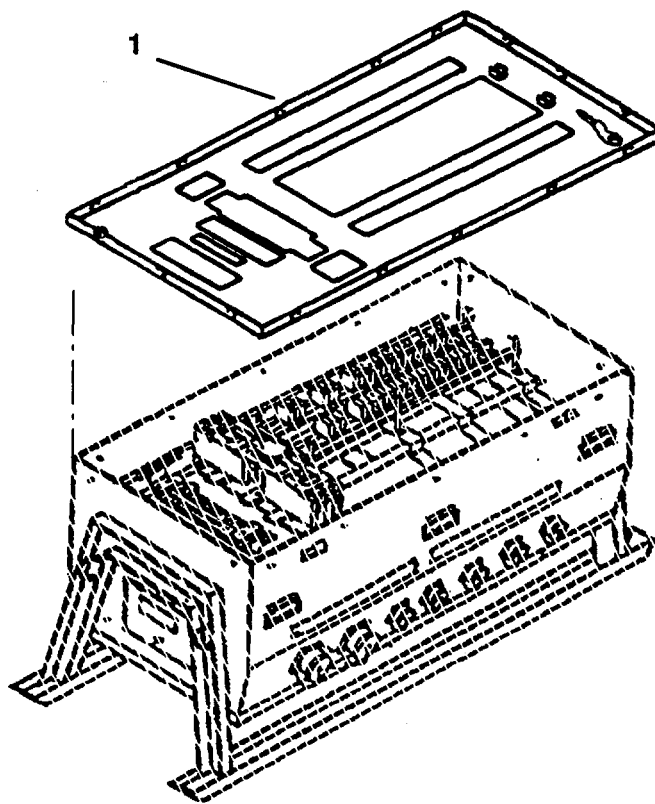

Figure 5-2. Deadfront Panel Assembly.

---

**5.8 400-AMP CIRCUIT BREAKERS.**

---

This task covers:           a. Removal           b. Installation

---

**INITIAL SETUP****Tools**

General Mechanic's Automotive Tool Kit  
(Item 2, Appendix B).  
Torque Wrench (Item 6, Appendix B).

**Equipment Conditions**

Reference  
Para 2.5 Equipment shut down.  
Para 4.15 Sub panel removed.

**Materials/Parts**

Tags (Item 14, Appendix E)

**WARNING****Personnel Required**

One.

High voltage is present in this equipment during operation. Do not attempt making any repairs without first shutting down all input power from the power distribution panel. Failure to observe this warning could result in serious injury or death.

---

**REMOVAL**

- a. Remove four screws (1, Figure 5-3), washers (2), and remove interlock (3), and eight washers (4).
- b. Remove four screws (5) and remove plate (6).
- c. Tag and identify leads. Loosen six screws (1 0) and remove electrical leads.
- d. Remove four screws (9).
- e. Remove six screws (7) and washers (8), and remove two 400-amp circuit breakers (11).

**INSTALLATION**

- a. Install two 400-amp circuit breakers (11), six washers (8), and screws (7).
- b. Install four screws (9) and tighten.
- c. Install six electrical leads and remove tags. Tighten six screws (1 0). Torque screws (7) and (1 0) to 275 in. lb (31.4 Nm).
- d. Install plate (6) and secure with four screws (5). Tighten screws.
- e. install eight washers (4) and interlock (3). Secure with four washers (2) and screws (1 ) Tighten screws.

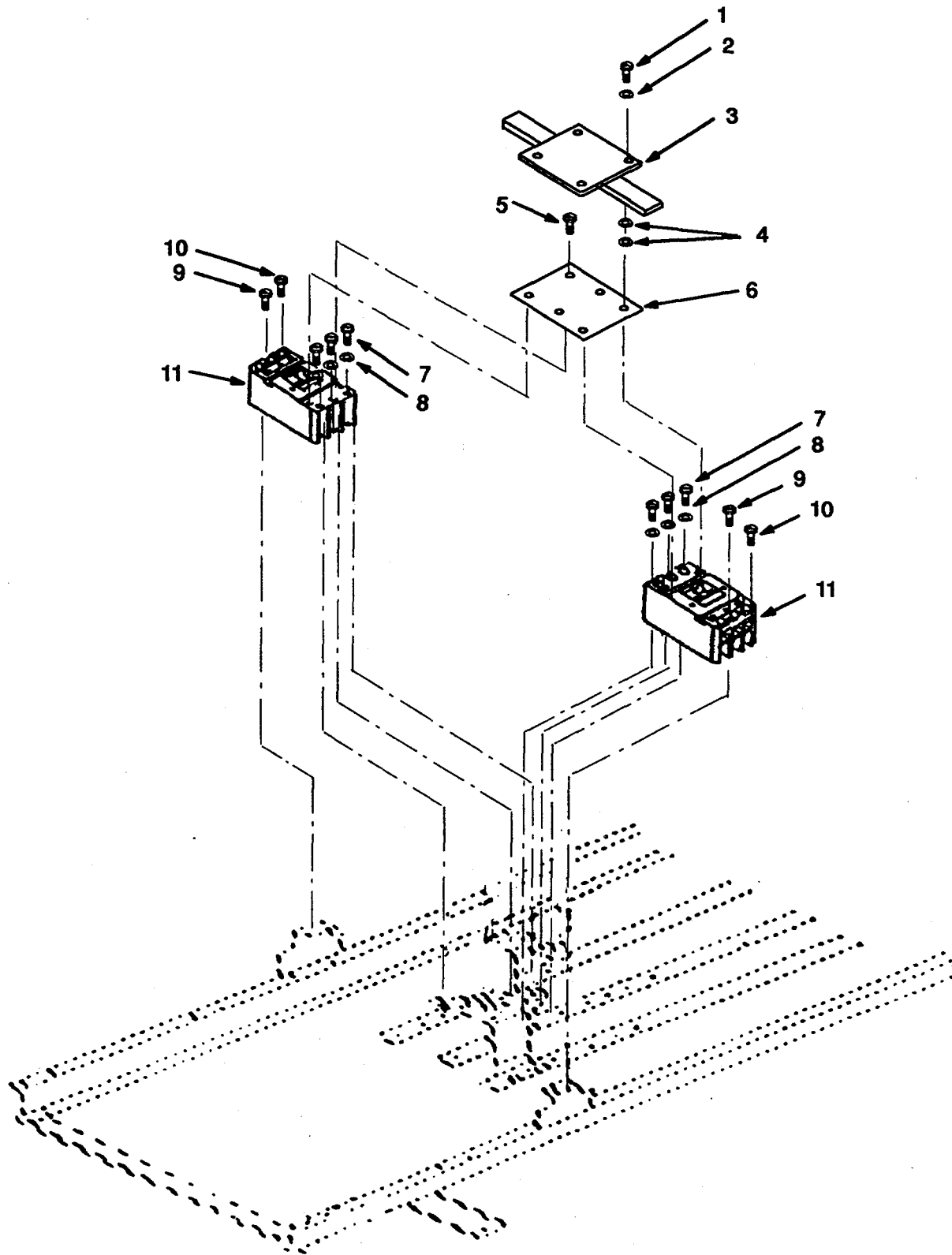

Figure 5-3. 400 Amp Circuit Breaker Assembly.

## 5.9 INTERIOR PANEL BOARD ASSEMBLY.

This task covers: a. Removal b. Installation

### INITIAL SETUP

#### Tools

General Mechanic's Automotive Tool Kit  
(Item 2, Appendix B).

#### Equipment Conditions

Reference  
Para 4.14 Sub panel removed.  
Para 4.16 Circuit breakers (60 and 100 amp)  
removed.  
Para 5.8 Circuit breakers (400 amp) removed.

#### Materials/Parts

Rivets, Plastic (Appendix F).  
Edge Trim, Plastic (Appendix F).

#### General Safety Instructions

#### **WARNING**

High voltage is present in this equipment during operation. Do not attempt making any repairs without first shutting down all input power from the power distribution panel. Failure to observe this warning could result in serious injury or death.

#### Personnel Required

One.

### REMOVAL

#### a. Sub Chassis and Bus Bar Connectors.

- (1) Remove eighteen screws (1 and 3, Figure 5-4), eighteen sub chassis connectors (2 and 4) and nine isolator blocks (5).
- (2) Remove eighteen screws (6) and nine mounting brackets (7).
- (3) Tag and identify two cables (1, Figure 5-5). Loosen two set screws (2) and remove cables (1) from connectors.
- (4) Tag and remove leads from neutral bus bar (4).
- (5) Remove two screws (3) and one neutral bus bar (4).
- (6) Remove four screws (5) and neutral bus bar bracket (6) from Z-rail (25).
- (7) Remove four screws (7) and two bus bar connectors (8).
- (8) Remove two plastic rivets (9) and two breaker insulations (10). Discard plastic rivets.

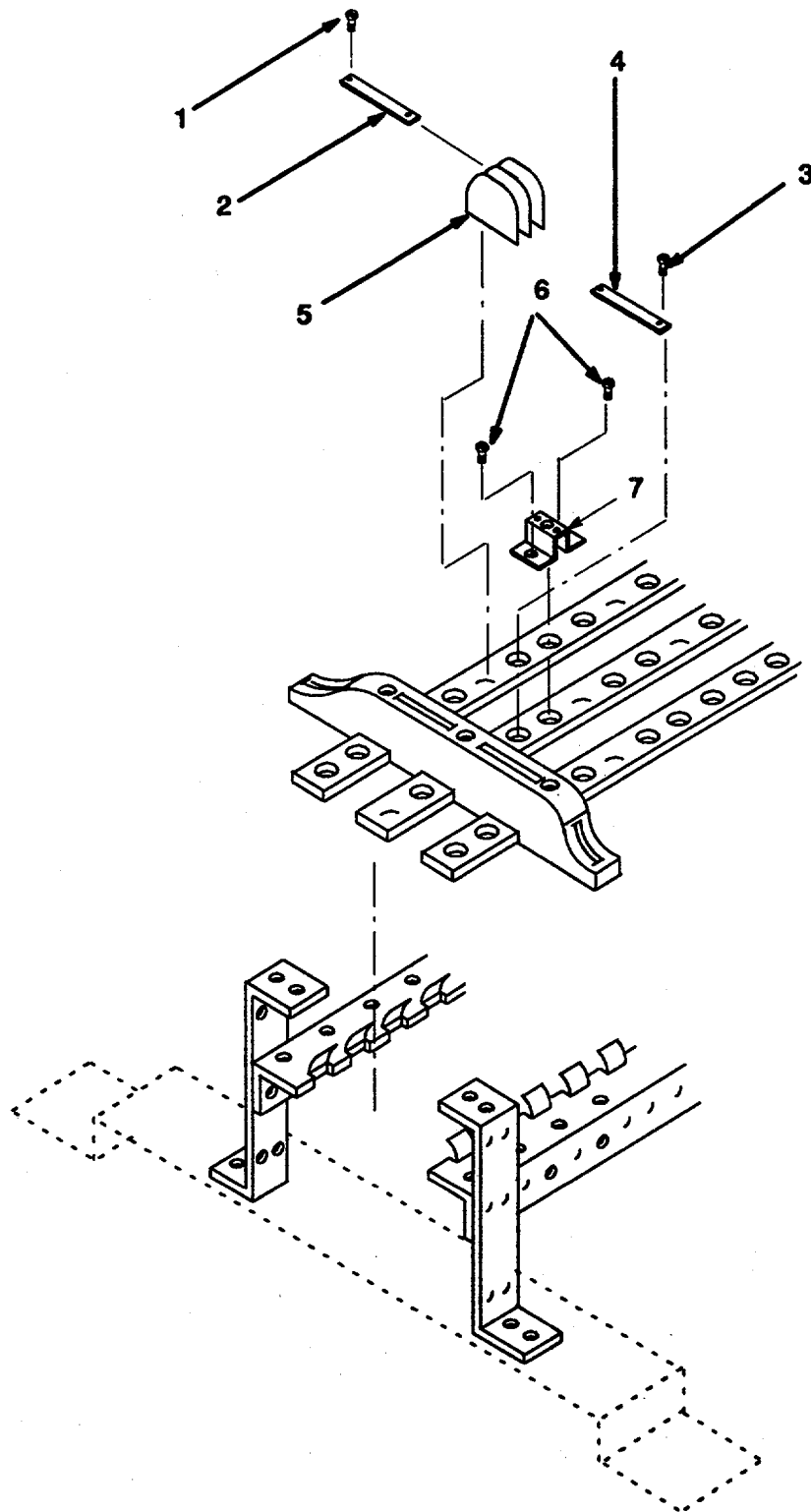

Figure 5-4. Interior Panel Board Assembly.

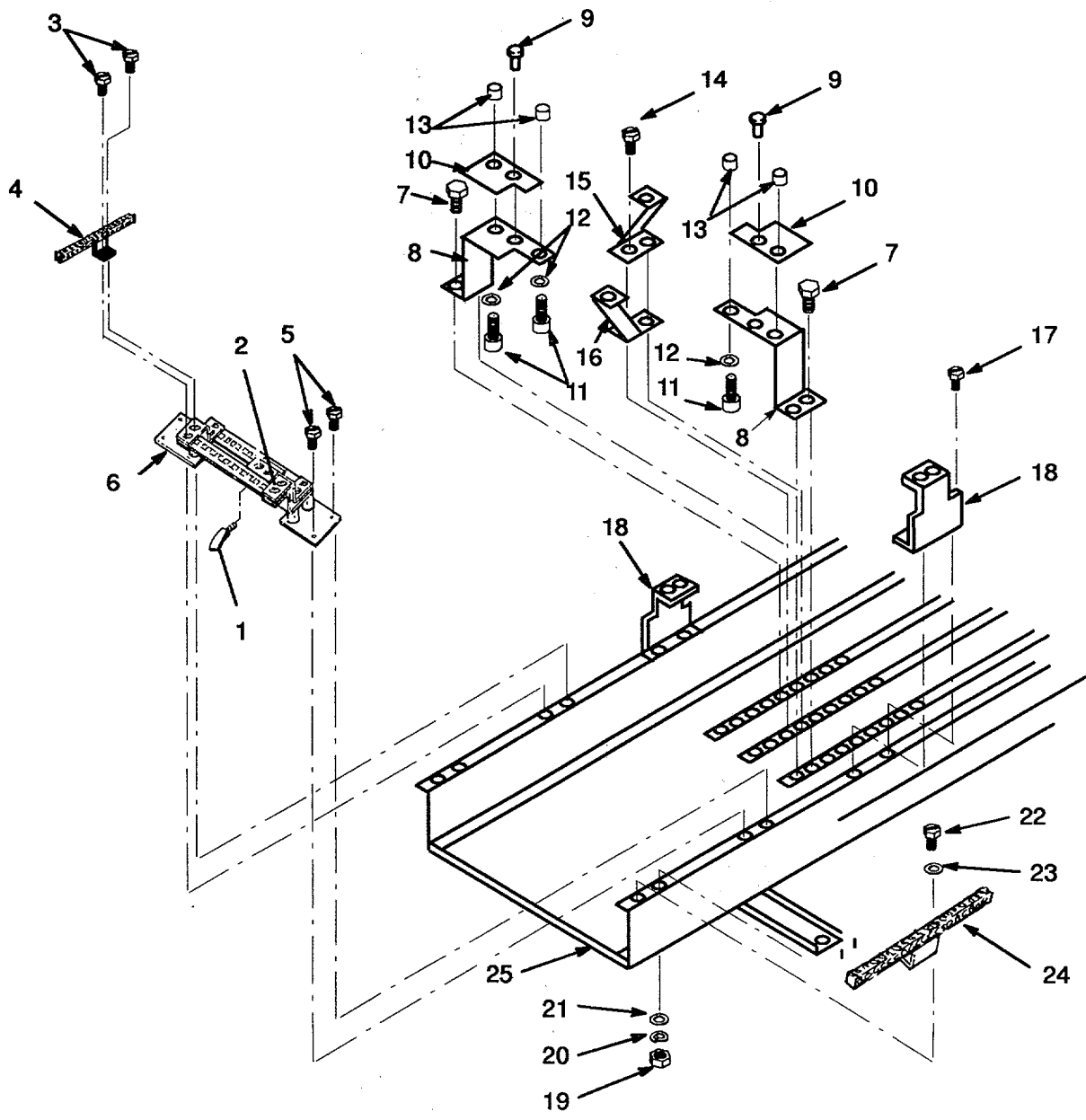

Figure 5-5. Interior Panel Board Assembly.

- (9) Remove four screws (11), flat washers (12) and connector spacer pads (13).
- (10) Remove two screws (14) and bus connectors (15 and 16).
- (11) Remove four screws (17) and two KD mounting brackets (18).



(12) Tag and remove leads from ground bus bar (24).

(13) Remove two nuts (19), lockwashers (20), flat washers (21), bolts (22), flat washers (23) and one ground bus bar (24) from Z-rail (25).

(14) Refer to sub chassis bus bar removal, para b, for further disassembly.

## INSTALLATION

- a. Install bus bar (24) on Z-rail (25) with two bolts (22), flat washers (23) and secure with two flat washers (21), lock washers (20) and nuts (1 9). Torque nuts per Appendix H.
- b. Install leads in bus bar (24) and remove tags.
- c. Install two KD mounting brackets (1 8) on Z-rail (25) with four screws (1 7). Tighten four screws.
- d. Place short bus connector (15) on top of bus connector (1 6) and install on middle bus bar with two screws (1 4). Center the two bus connectors (15 and 16) and tighten screws (1 4) per Appendix H.
- e. Install four connector spacer pads (13) on bus bar connectors (1 5 and 1 6) with four flat washers (1 2) and screws (11). Torque screws per Appendix H.
- f. Attach two bus bar connectors (8) to outer main bus bars with four screws (7). Align connector spacer pads (13) and tighten screws.
- g. Attach two breaker insulations (10) to two bus bar connectors (8) with two new plastic rivets (9).
- h. Attach neutral bus bar bracket (6) to Z-rail (25) with four screws (5). Tighten screws.
- i. Attach neutral bus bar (4) to bus bar bracket (6) with screws (3). Tighten screws.
- j. Install leads on neutral bus bar (4) and remove tags.
- k. Install two cables (1) in connectors. Torque set screws (2) per Appendix H.
- l. Attach nine mounting brackets (7, Figure 5-4) to center sub chassis bus bar with eighteen screws (6). Tighten screws.
- m. Place nine isolator blocks (5) over mounting brackets (7) and install eighteen sub chassis connectors (2 and 4) with eighteen screws (1 and 3). Tighten screws.
- n. Refer to equipment conditions and perform the installation procedures.

5.9 INTERIOR PANEL BOARD ASSEMBLY - CONTINUED.

REMOVAL

a. Sub chassis Bus Bars.

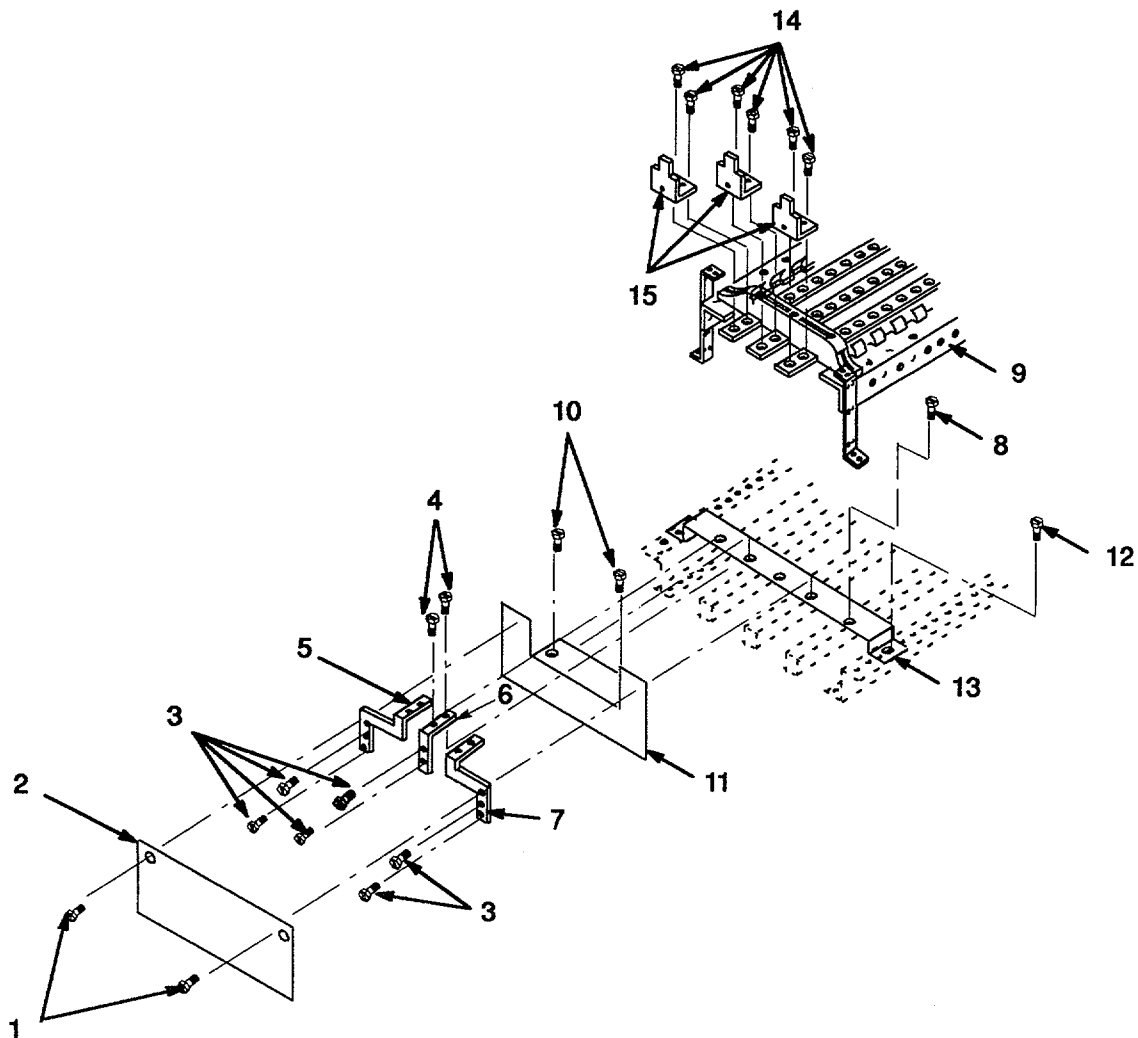

Figure 5-6. Sub Chassis Bus Bar.

- (1) Perform removal procedures in para 5-9.a.1.
- (2) Remove four plastic rivets (1, Figure 5-6) and two connector insulation (2).
- (3) Remove twelve screws (3).

- (4) Remove twelve screws (4), two connectors (5), two connectors (6), and two connectors (7).
- (5) Remove six screws (8) and sub chassis bus bar (9).
- (6) Remove four plastic rivets (10) and two paper insulators (11).
- (7) Remove six screws (12) and three sub chassis brackets (13).
- (8) Remove twelve screws (14) and six bus bar connectors (15).
- (9) Remove six screws (1, Figure 5-7) and two breaker mounting rails (2).
- (10) Remove six screws (3), three screws (4) and three bus supports (5) and bus bars (6).
- (11) Refer to main bus bar removal procedures, para c, for further disassembly.

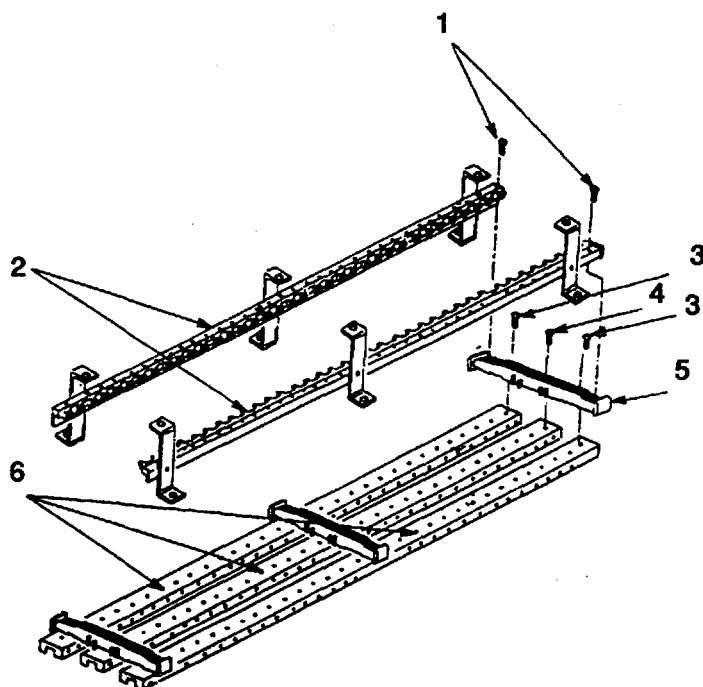

Figure 5-7. Sub Chassis Bus Bar.

---

**5.9 INTERIOR PANEL BOARD ASSEMBLY - CONTINUED.**

---

**INSTALLATION**

---

- a. Attach three bus supports (5, Figure 5-7) to three bus bars (6) with six screws (3) and three screws (4). Tighten nine screws.
- b. Attach two breaker mounting rails (2) to three bus supports (5) with six screws (1). Tighten screws.
- c. At 400 amp circuit breaker end, position three bus bar connectors (1 5, Figure 5-6) above the sixth hole from the end of main bus bar and install six screws (14). Tighten screws.
- d. At other end of main bus bar, position three bus bar connectors (1 5) above the second hole from bus bar end and install six screws (14). Tighten screws.
- e. Attach three sub chassis brackets (1 3) to Z-rail with six screws (1 2). Do not tighten screws (1 2) at this time.
- f. Attach two paper insulators (11) to sub chassis brackets (13) with four new plastic rivets (10).
- g. Attach sub chassis bus bar (9) to three sub chassis brackets (13) with six screws (8). Tighten six screws.
- h. Attach two connectors (5), two connectors (6) and two connectors (7) to six bus bar connectors (15) with twelve screws (4).
- i. Attach two connector insulations (2) to connectors (5 and 7) with four new plastic rivets (1).
- j. Refer to sub chassis and bus bar connectors, para a, installation procedures.

---

**REMOVAL**

## a. Main Bus Bars.

- (1) Perform removal procedures in paragraphs 5-9.a.1 and 5-9.b.1.
- (2) Remove nine screws (2), three bus bars (5) and nine spacers (25).
- (3) Remove four screws (1) and chassis bracket (20).
- (4) Remove four edge trims (3) and (4) if defective.
- (5) Remove six nuts (15), lockwashers (14), flat washers (13) and bolts (7).
- (6) Remove eight screws (6), two Z-rails (8), and two chassis brackets (9 and 10).
- (7) Remove nine screws (21), flatwashers (22), insulators (24) and three paper insulators (23) from three chassis brackets (9 and 10).
- (8) Remove six nuts (19), lock washers (18), flat washers (17), bolts (11) and three mounting rails (12) from support frame (16).

5.9 INTERIOR PANEL BOARD ASSEMBLY - CONTINUED.

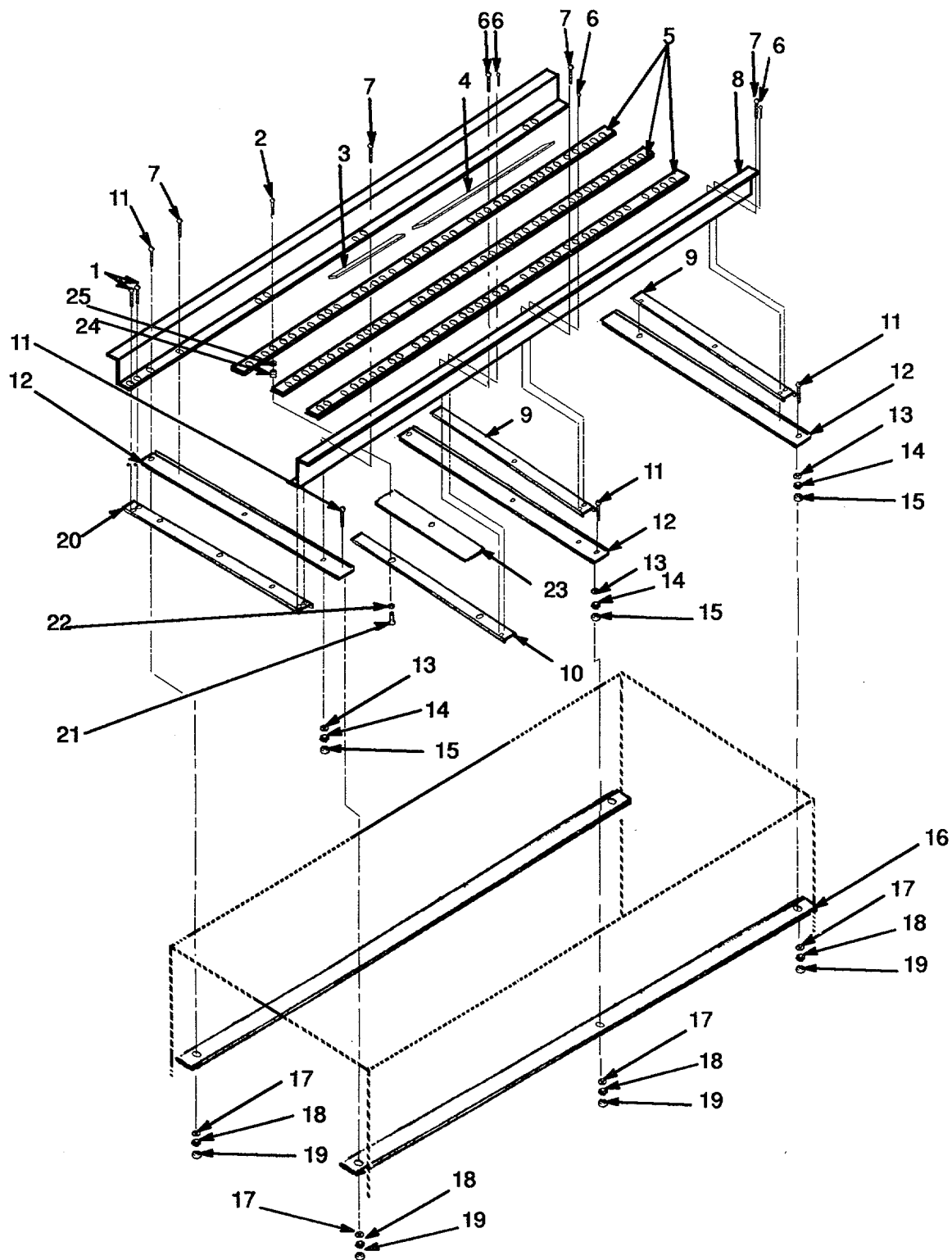

Figure 5-8. Sub Chassis Bus Bar.

---

**INSTALLATION**

---

- a. Attach three mounting rails (1 2) to support frame (16) with six bolts (11), flat washers (17), lock washers (18) and six nuts (19). Torque six bolts (19) per Appendix H.
- b. Attach three paper insulations (23) to three chassis brackets (9 and 10) with nine screws (21), flat washers (22) and insulators (24).

**NOTE**

The Z-rail (8), with two holes at one end, spaced approximately 0.5 inch apart, will be mounted on circuit breaker CB1 side of cabinet.

- c. Install six bolts (7) through Z-rails (8), two chassis brackets (9), three mounting rails (12) and secure with six flat washers (1 3), lockwashers (1 4) and nuts (1 5). Tighten nuts.

**NOTE**

Chassis bracket (10) must be spaced so three pre-drilled holes in main bus bars (5) align with three insulators (24).

- d. Install eight screws (6) through Z-rails (8) into chassis brackets (9 and 10). Tighten screws.
- e. Install four edge trims (3 and 4), if removed.
- f. Install chassis bracket (20) on two Z-rails (8) with four screws (1).
- g. Install nine spacers (25) and three main bus bars (5) on nine insulators (24) and secure with nine screws (2). Tighten screws.
- h. Perform installation procedures for sub chassis bus bar, para b, and sub chassis and bus bar connectors, para a.

---

**5-10 ELECTRICAL LEADS.**

---

This task covers:      a. Removal      b. Installation

---

**INITIAL SETUP****Tools**

General Mechanic's Automotive Tool Kit  
(Item 2, Appendix B).  
Torque Wrench (Item 6, Appendix B).

**Equipment Conditions**

Reference  
Para 2.5 Equipment shut down.  
Para 4.15 Sub panel removed.

**Materials/Parts**

Tags (Item 14, Appendix E).

**General Safety Instructions****WARNING****Personnel Required**

One.

High voltage is present in this equipment during operation. Do not attempt making any repairs without first shutting down all input power from the power distribution panel. Failure to observe this warning could result in serious injury or death.

---

**REMOVAL**

- a. Tag and identify leads at both ends.
- b. Loosen three screws (1) and remove leads (2) from 400-amp circuit breaker (3).
- c. Loosen three screws (4) on terminal block (5) and remove leads (2).
- d. Loosen screw (6) on terminal block (7) and remove ground wire (8).



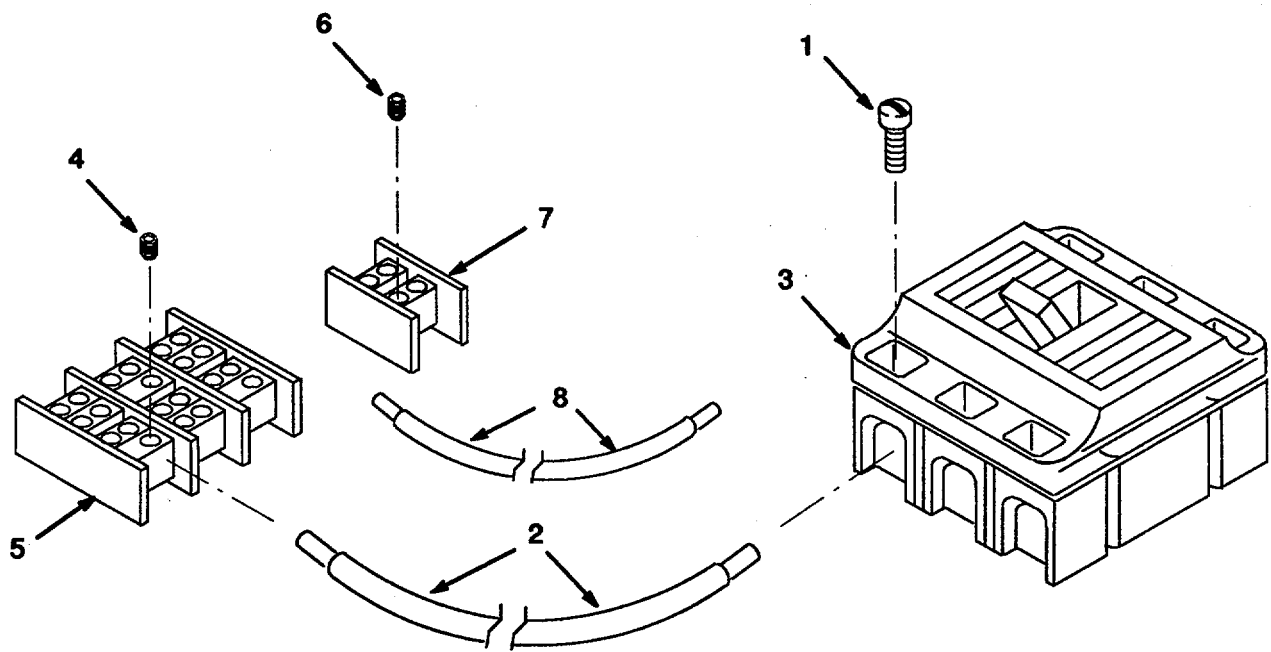

Figure 5-9. Electrical Leads.

#### INSTALLATION

- a. Install ground wire (8) in terminal block (7) and torque screw (6) to 45 in.-lb (5.1 Hm).
- b. Install three leads (2) in terminal block (5) and tighten screws (4) in accordance with the torque specifications shown in Appendix H).
- c. Install three leads (2) in 400-amp circuit breaker (3) and torque screws (1) to 275 in.-lb (31.4 Nm). Remove tags.

---

**5-10 ELECTRICAL LEADS.**

---

This task covers:       Repair

---

**INITIAL SETUP****Tools**

Crimp Tool, Pin Socket.  
Crimp Tool Kit, Pneumatic  
(Item 3, Appendix B).

**Equipment Conditions**

Reference  
Para 4.20 MS Connectors removed.

**Materials/Parts**

Connector (Appendix F).  
Contact (Appendix F).  
Contact (Appendix F).  
Cover (Appendix F).

**General Safety Instructions****WARNING**

High voltage is present in this equipment during operation. Do not attempt making any repairs without first shutting down all input power from the power distribution panel. Failure to observe this warning could result in serious injury or death.

**Personnel Required**

Two.

---

**REMOVAL**

a. Disassemble Connector.

**NOTE**

Nut (1) has a left-hand thread.

- (1) Unscrew and remove nut (1) from connector (2).
- (2) Remove, as an assembly, wires (3), rear support group (4), and forward support group (5).
- (3) Remove forward support group (5) from sockets (6).
- (4) Remove sockets (6) from rear support group (4), refer to Tables G-1 and G-2, Appendix G for proper removal tool.

b. Replace Defective Parts.

- (1) Refer to paragraph 5-14. Cable Assemblies, for connector socket replacement procedures. The procedures for replacing sockets or pins are identical. Paragraph 5-14 describes use of the pneumatic crimp tool system.
- (2) To determine correct wire length, wire insulation color, correct stripping of wire, refer to Table 4-6. For correct selection of pin/sockets and wiring, refer to the appropriate figure in Appendix F. These figures provide the necessary information to repair or fabricate the cables.

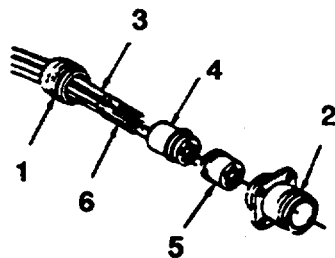

Figure 5-10. MS Connector.

**NOTE**

Splicing cables is not authorized. Cables that are damaged may be repaired by cutting off damaged section and reattaching connector.

c. Assembly Connector.

(1) Install wires (3) with sockets (6) attached into rear support group (4).

**NOTE**

Sockets lock in place in support group (4).

(2) Position forward support group (5) over sockets (6).

**NOTE**

- Make certain position markings on forward and rear support groups match.
- Forward support group (5) and connector (2) are keyed to fit together.

(3) Install rear support group (4), forward support group (5) and wires (3) into connector (2).

**NOTE**

Nut (1) has left-hand thread.

(4) Install nut (1) on connector (2).

**5-10 ELECTRICAL LEADS.**

This task covers:      a. Removal      b. Repair      c. Installation

**INITIAL SETUP****Tools**

General Mechanic's Automotive Tool Kit  
(Item 2, Appendix B).  
Portable Electric Drill (Item 4, Appendix B).  
Riveter, Blind Head (Item 5, Appendix B).

**Materials/Parts**

Paint (Item 4, Appendix E).  
Lock Washers (Item 3, Appendix F).  
Gasket Strip (Item 26, Appendix F).  
Latches (Item 8, Appendix F).  
Rivets (Item 7, Appendix F).

**Personnel Required.**

One

**Equipment Conditions**

Reference  
Para 2.5 Equipment shut down.

**General Safety Instructions****WARNING**

High voltage is present in this equipment during operation. Do not attempt making any repairs without first shutting down all input power from the power distribution panel. Failure to observe this warning could result in serious injury or death.

**REMOVAL**

Refer to Chapters 4 and 5 and remove all components of the power distribution panel.

**REPAIR**

Repair is limited to replacing defective parts, pounding out dents, welding, sanding, and painting. Refer to TM 43-0139 for painting instructions.

## a. Disassembly.

- (1) Remove eight nuts (1, Figure 5-11), flat washers (3), lockwashers (2), and four U-bolts (4). Discard lockwashers (2).
- (2) Remove nuts (5) from U-bolts (4).
- (3) Remove nut (6) lock washers (7), terminal (8), screw (9), lock washer (10), and ground lug (11).
- (4) Drill out four rivets (12) and remove two latches (13).
- (5) Remove four nuts (14), screws (15), and nameplate (16).

- (6) Drill out thirty rivets (1 7) and remove six handles (1 8).

**NOTE**

Items 23, 22, 21 and 20 are an assembly but must be removed individually to remove latch.

- (7) Remove two door assemblies (1 9) by sliding off of hinge.
- (8) Remove two knobs (20), screws (21), levers (22) and flat washers (23).
- (9) Remove strip gasket (24) if damaged and discard.

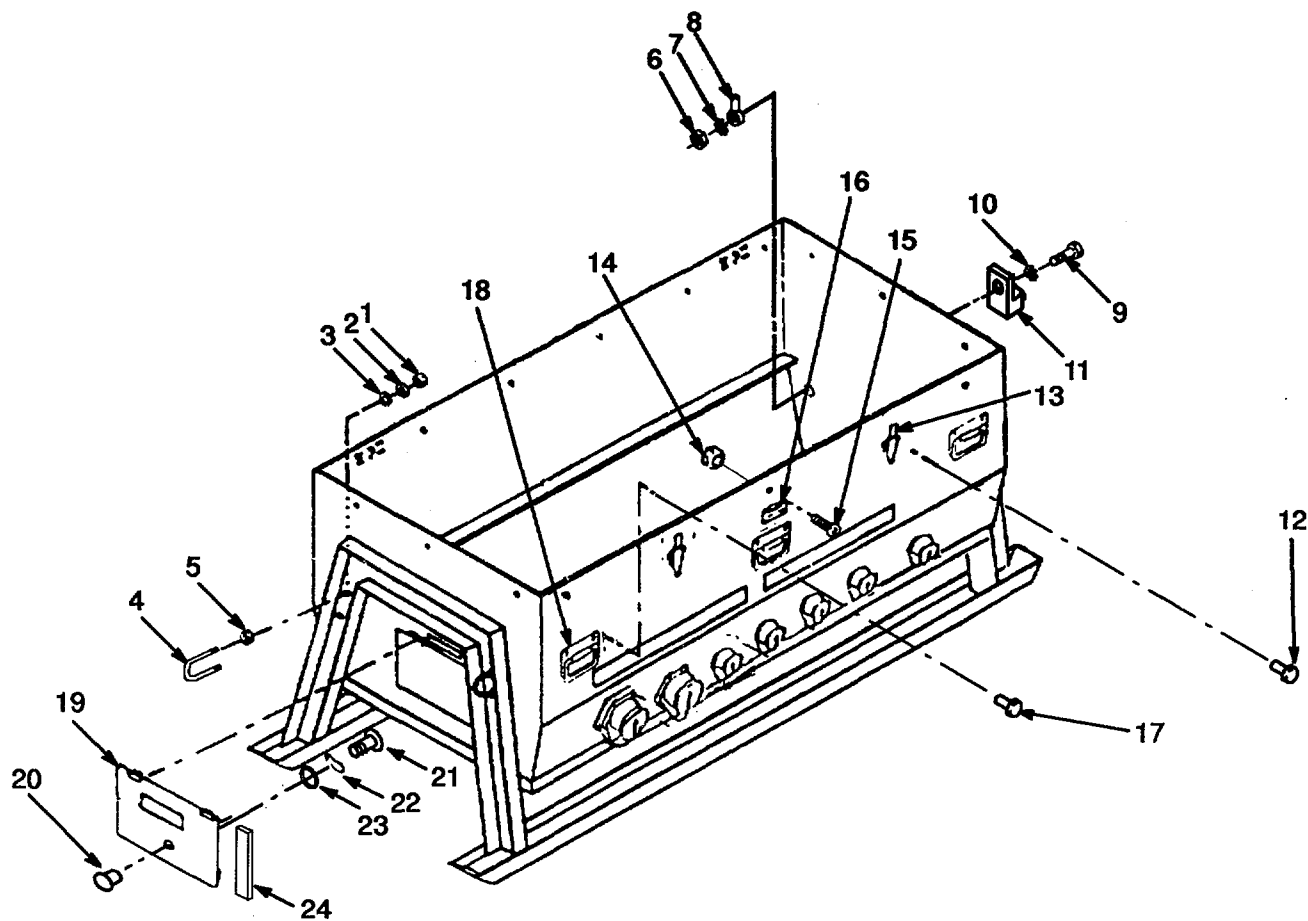

Figure 5-11. Cabinet Assembly.

---

**5-12 CABINET ASSEMBLY - CONTINUED.**

---

## b. Reassembly.

- (1) Install new gasket (24), if damaged, on door (19).
- (2) Install two flat washers (23), lever (22), screw (21) and knob (20) on door (19).
- (3) Install two door assemblies (1 9) by sliding onto hinge.
- (4) Install six handles (18) and 30 rivets (17).
- (5) Install nameplate (1 6), four screws (1 5), and four nuts (1 4). Tighten nuts.
- (6) Install two latches (13) and four rivets (12).
- (7) Install ground lug (11) lockwasher (10) and screw (9). Install terminal lug (8), lockwasher (7) and nut (6). Torque nut (6) per Appendix H.
- (8) Install eight nuts (5) on U-bolt (4). Install your U-bolts (4), eight new lockwashers (2), flat washer (3) and nuts (1). Torque eight nuts (1) per Appendix H.

---

**INSTALLATION**

Refer to Chapters 4 and 5 and install all components of the power distribution panel.

---

**5-13 CABLE ASSEMBLIES.**

---

This task covers:       Repair

---

**INITIAL SETUP****Tools**

General Mechanic's Automotive Tool Kit  
(Item 2, Appendix B).  
Portable Electric Drill (Item 4, Appendix B).  
Riveter, Blind Head (Item 5, Appendix B).

**Materials/Parts**

Connectors pins/sockets (Appendix F).  
Lubricant (Item 3, Appendix E).  
Colored tape (Items 9 thru 13, Appendix E).

**Personnel Required.**

One

**General Safety Instructions****WARNING**

High voltage is present in this equipment during operation. Do not attempt making any repairs without first shutting down all input power from the power distribution panel. Failure to observe this warning could result in serious injury or death.

---

**REPAIR****NOTE**

Female connectors use sockets and male connectors use pins. These procedures refer to pins but apply to both types of contacts.

- a. Disassemble connector.

**NOTE**

The cable gland nut (1) is a left-handed thread.

- (1) Using 10-inch slip joint pliers, loosen cable gland nut (1).
- (2) Using both hands, compress wire mesh (2) and slide gland nut (1) and mesh (2) 12 inches (30 cm) up the cable.
- (3) Loosen three screws (3) and remove connector head (4) from connector body (5).
- (4) Apply lubricant on cable directly behind connector body (5) and push cable into connector body (5) to force support group (6) out.

5-13 CABLE ASSEMBLIES.

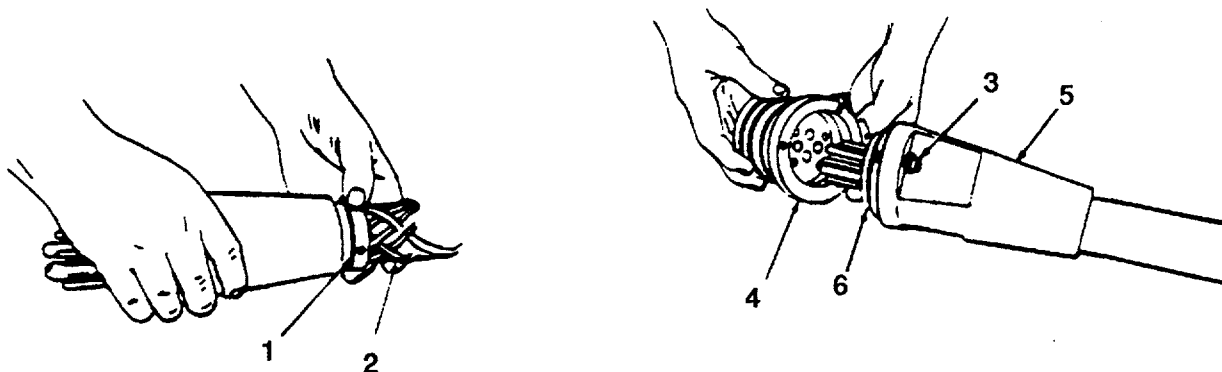

b. Remove connector parts.

- (1) Refer to Appendix G, Tables G-1 and G-2 for proper removal tool, remove pins (1) from support group (2).

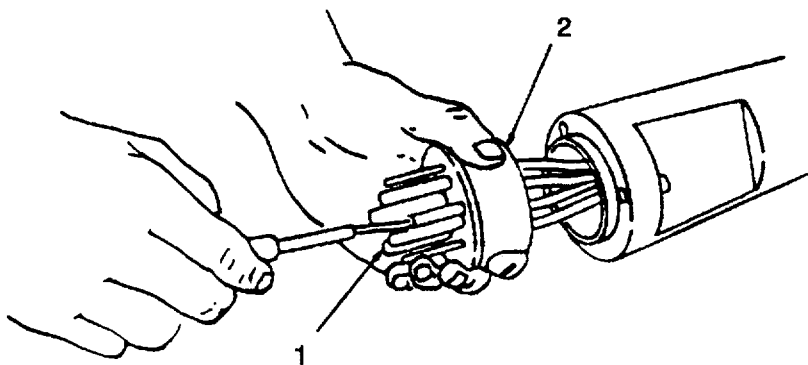

**NOTE**

If only one pin is damaged, it is necessary to cut all cable wires and replace all pins so the wires will be equal in length. If wires are uneven it will not be possible to reassemble connector.

- (2) Using hacksaw, cut through cable at least one inch (2.5 cm) from end of cable jacket.

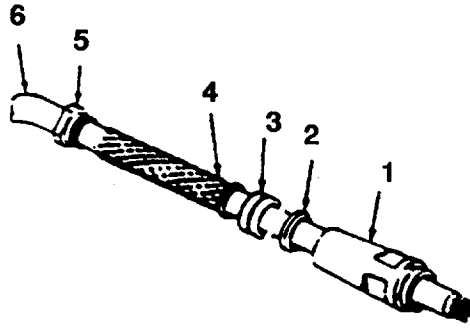

**NOTE**

Record the order of disassembly and note direction of connector parts as they are removed.

- (3) Slide connector body (1), two glands, (2 and 3) wire mesh (4), and gland nut (5) off cable (6).
- (4) Replace defective parts.

<b>CAUTION</b>
----------------

When installing both connectors on a length of bulk cable, the wire colors must match the pin/socket positions. Refer to Appendix G for proper connector configuration.

c. Crimp tool setup procedure.

- (1) Position Teflon washer in regulator and install regulator on air tank Tighten connection.
- (2) Apply teflon tape or pipe compound to threads on air hose and install air hose in regulator. Tighten connection.

**NOTE**

The crimper can be set up for operation by either the crimper handle or the foot control pedal. For handle (hand) operation, do step (3). For pedal (foot) operation, do step (4).

- (3) Set up crimper for hand operation, as follows:
  - (a) Remove plug from rear of crimper handle and install plug in center of rear casting.
  - (b) Apply thread sealant to, and install, the 1/4inch NPT coupler in rear of crimper handle. Tighten coupler.
  - (c) Install the male, quick-disconnect fitting in coupler. Tighten fitting in coupler.
  - (d) Install air hose from regulator onto quick disconnect fitting.

---

**5-13 CABLE ASSEMBLIES.**

---

- (4) Set up crimper for foot operation as follows:
  - (a) Install plug in rear of crimper handle.
  - (b) Apply thread sealant to, and install, the 1/4-inch NPT coupler in center of rear casing. Tighten coupler.
  - (c) Install the male, quick-disconnect fitting in coupler. Tighten coupler.
  - (d) Install air hose between foot pedal and quick-disconnect fitting in rear of casing.
  - (e) Install air hose from regulator onto foot control pedal.

**WARNING**

Misuse of compressed air could result in death or serious injury. When working with air, always use eye protection and any other protective equipment.

- (5) Open valve on air tank and adjust regulator to approximately 1 00 psi.

**NOTE**

When regulator valve is opened, the button on the front of the crimper handle will pop out if the crimper is set up for hand operation. If the crimper is set up for foot control, the button on the handle will not pop out.

- (6) Turn the regulator valve to the on position.
- (7) Refer to Appendix G and select the proper size locator and die to be used. This is determined by the size of the pins or sockets being installed.
- (8) Remove the retaining ring (1) from the front of the crimping tool and install locator (2), taking care to align notches in locator with notches in crimper.

**NOTE**

When properly installed, locator will be flush with retainer face.

- (9) Align pin (3) on crimper with hole (4) on back of die (5) and install die.

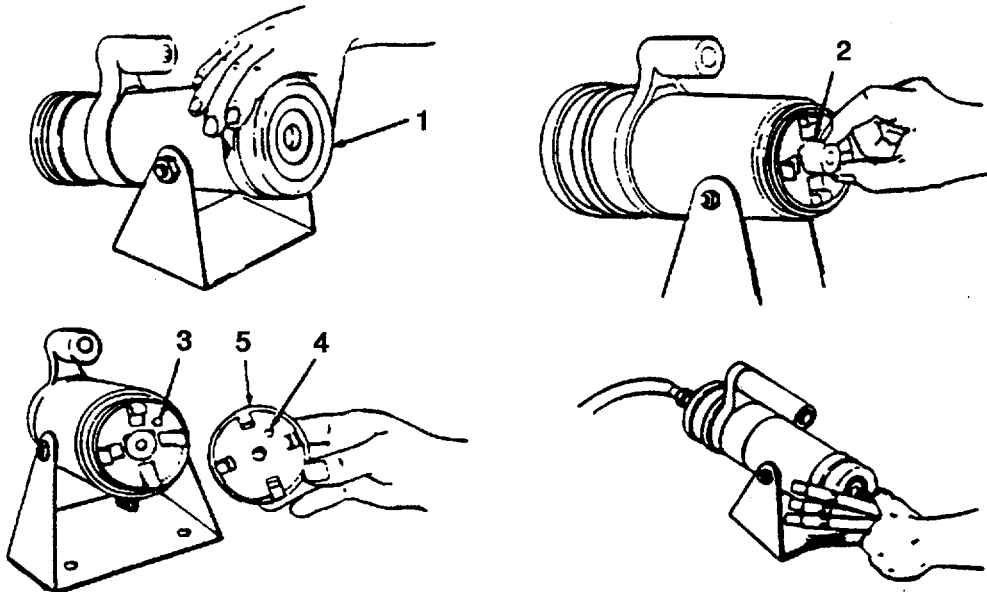

**NOTE**

When properly installed, die should sit flat against retainer face.

(10) Install retaining ring on crimper and tighten by hand.

(11) To operate crimper, slide pin or socket into the locator with the wire attached. Using button on crimper handle, or foot pedal, as applicable, activate crimper until crimp is complete. Then, release air pressure and remove pin or socket.

d. Install connector parts.

(1) Install gland nut (5), wire mesh (4), glands (3 and 2), and connect body (1) on cable (6).

(2) Cut and remove proper length of insulation from outer cable jacket and wires. Refer to Appendix G.

(3) Using multimeter, perform continuity test (Table 4-5) to determine correct pin-to-wire installation.

(4) Tag wires with colored tape (Items 9 through 13, Appendix E) in accordance with Appendix G.

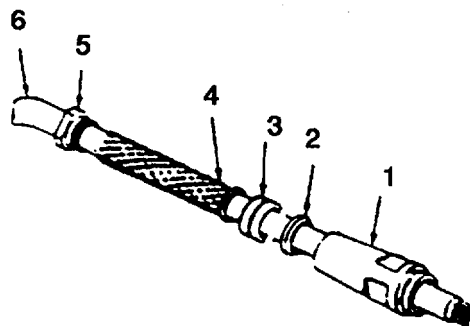

---

**5.13 CABLE ASSEMBLIES-CONTINUED.**

---

**NOTE**

The long pin attaches to the neutral wire of the male connector.

- (5) Slide pins onto cable wires and crimp in place.

**e. Assemble connector.****NOTE**

- Do not rely on color of wire insulation for phase color-coding. The insulation on the wires inside the cable may vary depending upon supplier. Wires will be marked with colored tape to designate phases. Perform continuity test to verify correct phase designation in accordance with colored tape.
  - Refer to Appendix G to determine correct pin letter and wire code.
  - Use lubricant (item 3, Appendix E) to aid installation of pins into support group.
- (1) Refer to Appendix G for proper insert tools. Using insert tools (1), insert pins (2) into support group (3).

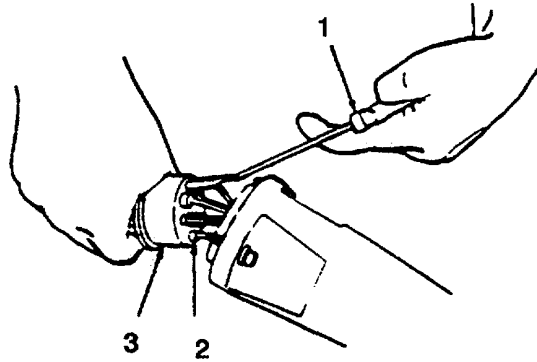
**NOTE**

Refer to Appendix G to determine correct pin-to-key position for connector.

(2) The following is an alternative procedure for 100-amp, 8-pin and 60-amp, 5-pin cable connectors. This procedure is a method for inserting the pins collectively into the support group.

- (a) Use lubricant (Item 3, Appendix E) to aid installation of pins into support group.
- (b) Start the A-pin into support group (1).
- (c) Start the N-pin into support group (1).
- (d) Slide support group (1) halfway over the A-and N-pins.
- (e) Start the B-pin into support group (1).
- (f) Start the C-pin into support group (1).
- (g) Slide support group (1) as far as possible over all pins.
- (h) Rock support group (1) toward the A-pin until it locks into position.
- (i) Rock support group (1) toward the N-pin until it locks into position.
- (j) Grasp the C-pin wire and push the wire toward support group (1) while rocking the support group toward the C-pin until it locks into position.
- (k) Grasp the Spin wire and push the wire toward support group (1) while rocking the support group toward the B-pin until it locks into position.
- (l) Select a G-pin wire nearest to its support group (1) hole. Use long-nosed pliers to grasp the pin and insert the pin into its hole and lock into position.
- (m) Insert remaining G-pins into support group (1) as described above.

**5.13 CABLE ASSEMBLES - CONTINUED.**

- (3) Slide connector body (2) down cable and position support group (1) and connector body together.
- (4) Install connector head (3) on connector body (2) and tighten three screws (4).

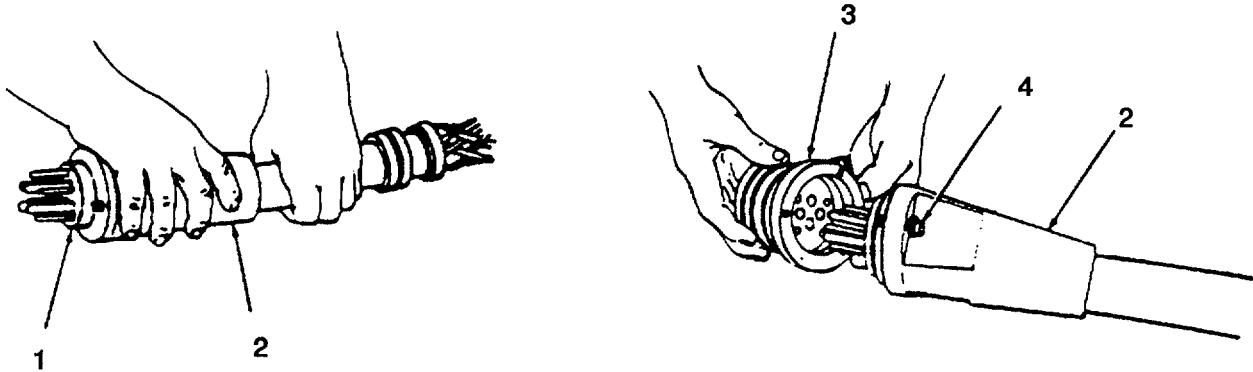

**NOTE**

The cable nut (4) is a left-handed thread.

- (5) Slide glands (1 and 2), wire mesh (3), and cable gland nut (4) into body (5) and tighten nut.
- (6) Perform continuity check (Table 4-5) to verify correct assembly.

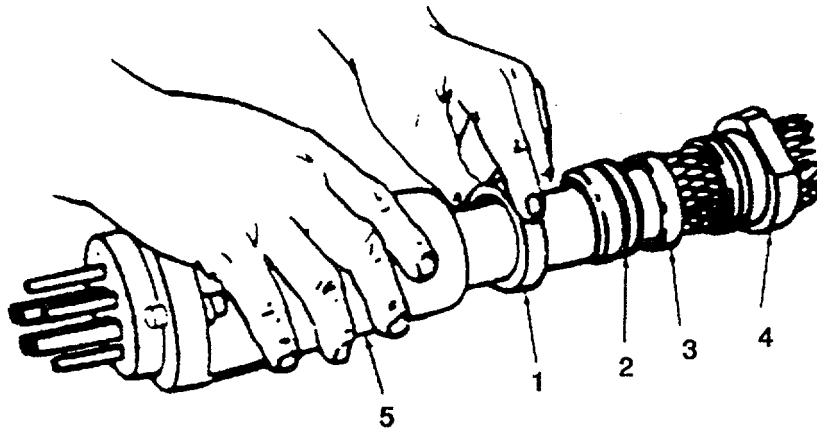

**APPENDIX A  
REFERENCES**

---

**A.1 SCOPE.** This appendix lists all forms, field manuals, technical manuals, and miscellaneous publications referenced in this manual.

**A.2 FORMS.**

Equipment Inspection and Maintenance Work Sheet.....	DA Form 2404
Product Quality Deficiency Report (Category 11) .....	SF 368
Recommended Changes to Equipment Technical Publications .....	DA Form 2028-2
Report of Discrepancy.....	SF 364

**A.3 FIELD MANUALS.**

Electrical Power Generation in the Field.....	FM 20-31
First Aid for Soldiers.....	FM 21-11
Under, Biological, and Chemical Decontamination .....	FM 3-5
NBC Contamination Avoidance .....	FM 3-3

**A.4 TECHNICAL MANUALS.**

Operator's Manual for Welding Theory and Application .....	TM 9-237
Packaging of Material: Preservation (Vol. 1).....	TM 38-230-1
Packaging of Material: Preservation (Vol. 2).....	TM 38-230-2
Painting Instructions for Army Material .....	TM 43-0139
Installation Practices for Aircraft Electric and Electronic Wiring (TO 1-1A-14) .....	TM 55-1500-323-24
Operator, Unit and Direct Support Maintenance Manual for DISE/PDISE .....	TM 9-6150-226-13
Procedures for Destruction of Equipment to Prevent Enemy Use (Mobility Equipment Command) .....	TM 750-244-3

**A.5 MISCELLANEOUS PUBLICATION.**

Army Maintenance Management System (TAMMS) .....	DA PAM 738-750
Solder and Soldering.....	TB SIG 222
Cables, (Power and Special Purpose) and Wire, Electrical (300 and 600 Volts).....	MIL-C-3432
Insulation Sleeving, Electrical, Heat Shrinkable, Polynesian, Flexible, Cross-Linked .....	MIL-1-23053/5
Marking of Electrical Wires and Cables.....	MIL-M-60903
Military Standard; Abbreviations for Use on Drawings, and in Specifications, Standards and Technical Documents .....	MIL-STD-12D



## APPENDIX B

MAINTENANCE ALLOCATION CHART

---

## SECTION I. INTRODUCTION

**B.1 GENERAL**

a. This section provides a general explanation of all maintenance and repair functions authorized at various maintenance levels.

b. The Maintenance Allocation Chart (MAC) in Section II designates overall authority and responsibility for the performance of maintenance functions on the identified end item or component. The application of maintenance functions to the end item or component will be consistent with the capacities and capabilities of the designated maintenance categories.

c. Section III lists the tools and test equipment (both special tools and common tools sets) required for each maintenance function as referenced from Section II.

d. Section IV contains supplemental instructions and explanatory notes for a particular maintenance function.

**B.2 MAINTENANCE FUNCTIONS.** Maintenance functions will be limited to and defined as follows:

a. Inspect. To determine the serviceability of an item by comparing its physical, mechanical, and /or electrical characteristics with established standards through examination (e.g. by sight, sound, or feel).

b. Test. To verify serviceability by measuring the mechanical, pneumatic, hydraulic, or electrical characteristics of an item and comparing those characteristics with prescribed standards.

c. Service. Operations required periodically to keep an item in proper operating condition, i.e., to dean (includes decontaminate, when required), to preserve, to drain, to paint, or to replenish fuel, lubricants, chemical fluids, or gases.

d. Adjust. To maintain or regulate, within prescribed limits, by bringing into proper or exact position or by setting the operating characteristics to specified parameters.

e. Align. To adjust specified variable elements of an item to bring about optimum or desired performance.

f. Calibrate. To determine and cause corrections or adjustments to be adjusted on instruments or test, measuring, and diagnostic equipment used in precision measurement. Consists of comparisons of two instruments, one of which is a certified standard of known accuracy, to detect and adjust any discrepancy in the accuracy of the instrument being compared.

g. Remove/install. To remove and install the same item when required to perform service or other maintenance functions. Install may be the act of emplacing, seating, or fixing into position a spare, repair part, or module (component or assembly) in a manner to allow the proper functioning of an equipment or system.

h. Replace. To remove an unserviceable item and install a serviceable counterpart in its place. Replace is authorized by the MAC and is shown as the 3rd position code of the SMR code.

i. Repair. The application of maintenance services, including fault location/troubleshooting, removal/installation, and disassembly/assembly procedures, and maintenance actions to identify troubles and restore serviceability to an item by correcting specific damage, fault, malfunction, or failure in a part, subassembly, module (component or assembly), end item, or system.

j. Overhaul. That maintenance effort (services/actions) prescribed to restore an item to a completely serviceable/operational condition as required by maintenance standards in appropriate technical publications (i.e., DMWR). Overhaul is normally the highest degree of maintenance performed by the Army. Overhaul does not normally return an item to like new condition.

**B.3 EXPLANATION OF COLUMNS IN THE MAC, SECTION II.**

a. Column 1. Group Number. Column 1 lists functional group code numbers, the purpose of which is to identify maintenance significant components, assemblies, subassemblies, and modules with the next higher assembly.

b. Column 2. Component/Assembly. Column 2 contains the names of components, assemblies, subassemblies, and modules for which maintenance is authorized.

c. Column 3. Maintenance Function. Column 3 lists the functions to be performed on the item listed in Column 2. (For detailed explanation of these functions, refer to paragraph B-2.)

d. Column 4. Maintenance Level. Column 4 specifies, by the listing of work time figures in the appropriate sub-column(s), the lowest level of maintenance authorized to perform the function listed in Column 3. This figure represents the active time required to perform the maintenance function at the indicated level of maintenance. If the number or complexity of the tasks within the listed maintenance function varies at different maintenance levels, appropriate work time figures will be shown for each level. The work time figure represents the average time required to restore an item (assembly, subassembly, component, module, end item, or system) to a serviceable condition under typical field operating conditions. This time includes preparation time (including any necessary disassembly/assembly time), troubleshooting/fault location time, and quality assurance/quality control time in addition to the time required to perform the specific tasks identified for the maintenance functions authorized in the Maintenance Allocation Chart. The symbol designation for the various maintenance levels are as follows:

Code	Explanation
C.....	Operator or crew
O.....	Unit Maintenance
F.....	Direct Support Maintenance
H.....	General Support Maintenance
D.....	Depot Maintenance

e. Column 5. Tools and Equipment. Column 5 specifies, by code, those common tools sets (not individual tools) and special tools, TMDE, and support equipment required to perform the designated function.

f. Column 6. Remarks. This column shall, when applicable, contain a letter code, in alphabetic order which shall be keyed to the remarks contained in Section IV.

**B.4 EXPLANATION OF COLUMNS IN TOOL AND TEST EQUIPMENT REQUIREMENTS, SECTION III.**

- a. Column 1. Tool or Test Equipment Reference Code. The tool and test equipment reference code correlates with a code used in the MAC, Section II, Column 5.
- b. Column 2. Maintenance Level. The lowest level of maintenance authorized to use the tool or test equipment.
- c. Column 3. Nomenclature. Name or identification of the tool or test equipment.
- d. Column 4. National/NATO Stock Number. The National or NATO Stock Number of the tool or test equipment.
- e. Column 5. Tool Number. The manufacturer's part number.

**B.5 EXPLANATION OF COLUMNS IN REMARKS, SECTION IV.**

- a. Column 1, Reference Code. The code recorded in Column 6, Section II.
- b. Column 2. Remarks. This column lists information pertinent to the maintenance function being performed as indicated in the MAC, Section II.

Section II. MAINTENANCE ALLOCATION CHART

(1) GROUP NUMBER	(2) COMPONENT ASSEMBLY	(3) MAINTENANCE FUNCTION	(4) MAINTENANCE CATEGORY					(5) TOOLS AND EQUIP	(6) REMARKS
			UNIT		DS	GS	DEPOT		
			C	O	F	H	D		
00	POWER DISTRIBUTION PANEL	Test		.2					
		Inspect	1.6						
		Replace		2.2					
		Repair		2.1	10.1				
01	TOP COVER ASSEMBLY	Inspect	.1						
		Replace		.1				2, 4, 5	
		Repair			.3			2,	
		Inspect	.1					2	
0101	CABLE, RESTRAINING, TOP COVER	Replace		.1					
02	PANEL ASSEMBLY, DEADFRONT	Inspect	.1						
		Replace		.2				2	
		Repair			.2			2	
		Inspect	.1						
03	SUB PANEL	Replace		.1				2	
0301	INDICATOR LIGHT ASSEMBLY AND INDICATOR LIGHT BULB	Inspect	.2						
		Replace		.4				2, 7, 8	
04	CIRCUIT BREAKERS	Inspect	.1						
		Test		.1				1	
		Replace		.3	1.0			2, 6	
05	INTERIOR PANEL BOARD ASSEMBLY	Inspect	.1						
		Replace			2.4			2	
06	TERMINAL BLOCKS	Inspect	.1						
		Replace		.2				2,	
07	FUSE HOLDER	Inspect	.1						
		Replace		.2				2, 7, 8	
0701	FUSE	Inspect	.1						
		Replace		.1					
08	SOLENOID, INTERLOCK	Inspect	.1						
		Replace		.2				2,7,8	
09	LEADS, ELECTRICAL	Inspect	.1						
		Replace			.4			2	

(1) GROUP NUMBER	(2) COMPONENT ASSEMBLY	(3) MAINTENANCE FUNCTION	(4) MAINTENANCE CATEGORY					(5) TOOLS AND EQUIP	(6) REMARKS
			UNIT		DS	GS	DEPOT		
			C	O	F	H	D		
10	CONNECTORS, MS	Inspect	.1						
		Test	.1					1	
		Replace	.2					2	
		Repair	.3					3	
11	CABINET ASSEMBLY	Inspect	.1						
		Replace			4.0			2	
		Repair			2.0			2, 4, 5	
12	CABLE ASSEMBLIES	Inspect	.1						
		Test		.2				1	A
		Repair			.2			3	

**SECTION III. TOOLS AND TEST EQUIPMENT REQUIREMENTS**

TOOL OR TEST EQUIPMENT REF CODE	MAINTENANCE CATEGORY	NOMENCLATURE	NATIONAL/NATO STOCK NUMBER	TOOL NUMBER
1	0	MULTIMETER, DIGITAL AN/PSM-45 OR EQUIVALENT	6625-01-129-2512	AN/PSM-45
2	O, F	TOOL KIT, GENERAL MECHANIC'S AUTOMOTIVE	5180-00-177-7033	SC 5180-90-CL N26
3	F	CRIMP TOOL KIT, PNEUMATIC	5120-01-235-7875	400-1 -200-5KL
4	F	DRILL, ELECT, PORTABLE 8845 OR EQUIVALENT	5130-00-226-5586	8845
5	F	RIVETED, BLIND HEAD G749 OR EQUIVALENT	5120-00-148-5847	G749
6	F	WRENCH, TORQUE 6063 OR EQUIVALENT	5120-00-177-7328	6063
7	F	SOLDERING IRON		
8	F	HEAT GUN		

**SECTION IV. REMARKS**

REFERENCE CODE	REMARKS
A	Fabrication of power cables assemblies is authorized at direct support maintenance level.
B	Replace 60 and 1 00 amp Circuit breakers at unit level.

**APPENDIX C  
COMPONENTS OF END ITEM (COEI) AND BASIC ISSUE ITEMS (BII) LISTS**

---

**SECTION I. INTRODUCTION**

**C.1 SCOPE.** This appendix lists components of the end item and basic issue items for the power distribution panel to help you inventory the items for safe and efficient operation of the equipment.

**C.2 GENERAL** The Components of End Item and Basic Issue items(BII) Lists are divided into the following sections: a. Section II. Components of End item. This listing is for information purposes only, and is not authorized to requisition replacements. These items are part of the power distribution panel, but they are to be removed and separately packaged for transportation or shipment. As part of the end item, these items must be with the end item whenever it is issued or transferred between property accounts. Illustrations are furnished to help you find and identify the items. b. Section II. Basic Issue Items. These essential items are required to place the power distribution panel in operation, operate it, and to do emergency repairs. Although shipped separately packaged, BII must be with the power distribution during operation and when it is transferred between property accounts. Listing items is your authority to request/requisition them for replacement based on authorization of the end item by the TOE/MTOE. Illustrations are furnished to help you find and identify the items.

**C.3 EXPLANATION OF COLUMNS.**

- a. Column (1). Illustration Number, gives you the number of the item illustrated.
- b. Column (2). National Stock Number. identifies the stock number of the item to be used for requisitioning purposes.
- c. Column (3). Description and Usable On Code, identifies the Federal item name (in all capital letters) followed by a minimum description when needed. The last line below the description is the CAGEC (commercial and Government entity code) (in parentheses) and the part number. If the item you need is not the same for different models of the equipment, a Usable On Code will appear on the right side of the description column on the same line as the part number. These codes are identified below as:

Code	Not Applicable	Used On
------	----------------	---------

- d. Column (4). U/I (Unit of Issue), indicates how the item is issued for the National Stock Number shown on column two.
- e. Column (5). Qty Rqd. indicates the quantity required.

**SECTION II. COMPONENTS OF END ITEM LIST - NOT APPLICABLE**

**SECTION III. BASIC ISSUE ITEMS LIST**

(1) Illus Number	(2) National Stock Number	(3) Description CAGEC and Part Number	(4) U/I Usable On Code	(5) Qty Rqd
		TM 9-6150-228-13&P	ea	1



**APPENDIX D  
ADDITIONAL AUTHORIZATION LIST (AAL)**

**SECTION I. INTRODUCTION**

**D.1 SCOPE.** This appendix lists additional items you are authorized for the support of the power distribution panel.

**D.2 GENERAL** This list identifies items that do not have to accompany the power distribution panel and that do not have to be turned in with it. These items are all authorized to you by CTA, MTOE, TDA, or JTA.

**D.3 EXPLANATION OF LISTING.** National stock numbers, descriptions, and quantities are provided to help you identify and request the additional items you require to support this equipment. The items are listed in alphabetical sequence by item name. If the item you require differs between serial numbers of the same model, effective serial numbers are shown in the last line of the description. If item required differs for different models of this equipment, the model is shown under the "usable on" heading in the description column. These codes are identified as:

**SECTION II. ADDITIONAL AUTHORIZATION ITEMS LIST**

<b>(1) National Stock Number</b>	<b>(2) Description  Used On  CAGEC and Part Number Code</b>	<b>(3)  U/I</b>	<b>(4)  Qty Auth</b>
6150-01-220-5587	Cable Assembly, Power: 50-ft, 100-amp, 8-pin (81349) M29184/2	ea	4
6150-01-220-5588	Cable Assembly, Power: 100-ft, 60-amp, 5-pin (81349) M29184/3-02	ea	10
6150-01-258-1202	Power Cable, Input: 100-ft (81349) M29184/1 -02 (set of five)	ea	2

**APPENDIX E  
ADDITIONAL AUTHORIZATION LIST (AAL)**

**SECTION I. INTRODUCTION**

**E.1 SCOPE.**

This appendix lists expendable/durable supplies that you will need to operate and maintain the power distribution panel. This listing is for information only and is not authority to requisition the listed items. These items are authorized to you by CTA 50-790, Expendable/Durable Items (except medical, class V repair parts, and heraldic items), or CTA 8-100, Army Medical Department Expendable/Durable Items.

**E.2 EXPLANATION OF COLUMNS.**

- a. Column 1. Item Number. This number is assigned to the entry in the listing and is referenced in the narrative instructions to identify the item (e.g. "Use cleaning compound, item 3, Appendix E").
- b. Column 2. Level. This column identifies the lowest level of maintenance that requires the item.
- c. Column 3. National Stock Number. This is the national stock number assigned to the item which you can use to requisition it.
- d. Column 4. Item Name. Description. Commercial and Government Entity Code (CAGEC). and Part Number. This provides the other information you need to identify the item.
- e. Column 5. Unit of Measure. This code shows the physical measurement or count of an item, such as gallon, dozen, gross, etc.

**SECTION II. EXPENDABLE/DURABLE SUPPLIES AND REQUIREMENTS LIST**

(1) ITEM NUMBER	(2) LEVEL	(3) NATIONAL STOCK NUMBER	(4) ITEM NAME, DESCRIPTION CAGEC, PART NUMBER	(5) U/M
1	0	8040-01-038-5043	Cement, gasket, 8 oz (237 cc) can	oz
2	O	7930-00-249-8036	Detergent, general-purpose 5 lb (2.3 kg)	lb
3	O	6850-00-057-9360	Compound, cleaning and lubricating, electrical contact, 6-oz (1 77 cc) can	oz
4	O	8010-01-229-7546	Paint, CARC forest green, type 11, 1 -quart (0.94 liter)	qt

(1) ITEM NUMBER	(2) LEVEL	(3) NATIONAL STOCK NUMBER	(4) ITEM NAME, DESCRIPTION CAGEC, PART NUMBER	(5) U/M
5	O, F	7920-00-205-1711	Rag, wiping	ea
6	F	5970-00-944-1450	Sleeving, insulation, heat shrinkable, blue, 1 in. dia	v
7	F	3439-00-922-4555	Solder SN60WRMAP3	ea
8	O	7150-00-266-6711	Tape, masking, 314 in. (19.1mm)	ro
9	O, F	5970-00-689-3444	Tape, wire marker, black 1/2 x 1296 in. (1 2.7mm x 33m)	ro
10	O, F	5970-01-017-7388	Tape, wire marker, black 1/2 x 240 in. (1 2.7mm x 6m)	ro
11	O, F	5970-01-013-9366	Tape, wire marker, green 1/2 x 240 in. (1 2.7mm x 6m)	ro
12	O, F	5970-00-834-2569	Tape, wire marker, red 1/2 x 240 in. (1 2.7mm x 6m)	ro
13	O, F	5970-00-832-4299	Tape, wire marker, red 1/2 x 648 in. (1 2.7mm x 16m)	ro
14	O, F		Tags	v
15	O, F	5975-00-727-5153	Strap, tiedown MS 3367-4-9	v
16	O, F	5975-00-451 -5001	Strap, tiedown MS 3367-3-9	v
17	O, F	5975-01 -034-5871	Strap, tiedown MS 3367-7-0	v

APPENDIX F

OPERATOR, UNIT, AND DIRECT SUPPORT MAINTENANCE REPAIR PARTS

AND SPECIAL TOOLS LIST (RPSTL)

SECTION I. INTRODUCTION

**F.1 SCOPE.** This RPSTL lists and authorizes spares repair parts for performance of operator, unit, and organizational maintenance of the Power Distribution Panel. It authorizes the requisitioning, issue, and disposition of spares and repair parts as indicated by the source, maintenance, and recoverability (SMR) codes.

**F.2 GENERAL** In addition to Section I, Introduction, this Repair Parts and Special Tools List is divided into the following sections:

a. **Section I I. Repair Parts List.** A list of spares and repair parts authorized by this RPSTL for use in the performance of maintenance. This list also includes parts which must be removed for replacement of the authorized parts. Parts lists are composed of functional groups in ascending alphanumeric sequence, with the parts in each group listed in ascending figure and item number sequence. Bulk materials are listed in item name sequence. Items are shown in the associated illustration(s)/figure(s).

b. **Section III. Special Tools List.** A list of special tools, special TMDE, and other special support equipment authorized by this RPSTL (as indicated by Basis of Issue (BOI) information in DESCRIPTION AND USABLE ON CODE column) for the performance of maintenance.

c. **Section IV. Cross Reference Index.** A list, in National Item Identification Number (NIIN) sequence, of all National stock numbered items appearing in the listing, followed by a list in alphanumeric sequence of all part numbers appearing in the listings. National stock numbers and part numbers are cross referenced to each illustration figure and item number appearance. The figure and item number index lists figure and item numbers in alphanumeric sequence and cross references NSN, CAGEC and part number.

**F.3 EXPLANATION OF COLUMNS (SECTIONS II AND III).**

a. **ITEM NO. (Column (1)).** Indicates the number used to identify items called out in the illustration.

b. **SMR CODE. (Column (2)).** The Source, Maintenance, and Recoverability (SMR) code is a 5-position code containing supply/requisitioning information, maintenance category authorization criteria, and disposition instruction, as shown in the following breakout::

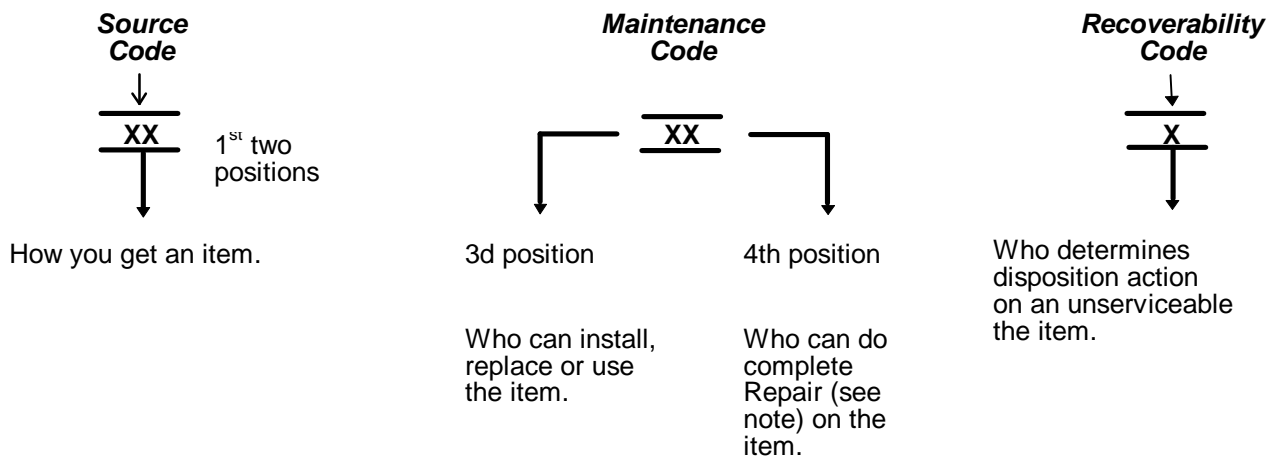

\* Complete Repair: Maintenance capacity, capability, and authority to perform all corrective maintenance tasks of the "Repair" function in a useless environment in order to restore serviceability to a failed item.

(1) Source code. The source code tells you how to get an item needed for maintenance, repair, or overhaul of an end item/equipment. Explanation of source codes as follows:

Code	Explanation
PA PB PC** PD PE PF PG	<p>Stocked items; use the applicable NSN to request(requisition items with these source codes. They are authorized to the category indicated by the code entered in the 3rd position of the SMR code.</p> <p>**NOTE: Items coded PC are subject to deterioration.</p>
KD KF KB	<p>Items with these codes are not to be requested/requisitioned individually. They re part of a kit which is authorized to the maintenance category indicated in the 3rd position of the SMR code. The complete kit must be requisitioned and applied.</p>
MO- (Made at Unit/AVUM Level) MF- (Made at DS/AVUM Level) MH- (Made at GS Level) ML- (Made at Specialized Repair Activity (SRA)) MD- (Made at Depot)	<p>Items with these codes are not to be requested/requisitioned individually. They must be made from bulk material which is identified by the part number in the DESCRIPTION and USABLE ON CODE (UOC) column and listed in the Bulk Material group of the repair parts list in this RPSTL. H the item is authorized to you by the 3rd position code of the SMR code, but the source code indicates it is made at a higher level, order the item from the higher level of maintenance.</p>
AO- (Assembled by Unit/AVUM Level) AF- (Assembled by DS/AVIM Level) AH- (Assembled by GS Category) AL- (Assembled by SRA) AD- (Assembled by Depot)	<p>Items with these codes are not to be requested/ requisitioned individually. The puts that make up the assembled item must be requisitioned or fabricated and assembled at the level of maintenance indicated by the source code. H the 3rd position code of the SMR code authorizes you to replace the item, but the source code indicates the items are assembled at a higher level, order the item from the higher level of maintenance.</p>
XA-	Do not requisition "XA"-coded item. Order its next higher assembly. (Refer to the NOTE below.)
XB-	If an UXB" item is not available from salvage, order it using the CAGEC and part number given.
XC-	Installation drawing, diagram, instruction sheet, field service drawing, that is identified manufacturer's part number.
XD-	Item is not stocked. Order an XD"-coded item through normal supply channels using the CAGEC and part number given, if no NSN is available.

NOTE: Cannibalization or controlled exchange, when authorized, may be used as a source of supply for items with the above source codes, except for those source coded XA or those aircraft support items restricted by requirements of AR-700-42.

(2) Maintenance Code. Maintenance codes tell you the level(s) of maintenance authorized to USE and REPAIR support items. The maintenance codes are entered in the third and fourth positions of the SMR code as follows:

(a) The maintenance code entered in the third position tells you the lowest maintenance level authorized to remove, replace, and use an item. The maintenance code entered in the third position will indicate authorization to one of the following levels of maintenance

CODE	Application/Explanation
C	-Crew or operator maintenance done within unit or aviation unit maintenance.
O	-Unit or aviation unit category can remove, replace, and use the item.
F	-Direct support or aviation intermediate level can remove, replace, and use the item.
H	-General support level can remove, replace, and use the item.
L	-Specialized repair activity can remove, replace, and use the item.
D	-Depot level can remove, replace, and use the item.

(b) The maintenance code entered in the fourth position tells whether or not the item is to be repaired and identifies the lowest maintenance level with the capability to do complete repair (i.e., perform all authorized repair functions). (NOTE: some limited repair may be done on the item at a lower level of maintenance, if authorized by the Maintenance Allocation Chart (MAC) and SMR codes.) This position will contain one of the maintenance codes

CODE	Application/Explanation
O	-Unit or aviation unit is the lowest level that can do complete repair of the item.
F	-Direct support or aviation intermediate is the lowest level that can do complete repair of the item.
H	-General support is the lowest level that can do complete repair of the item.
L	-Specialized repair activity (designate the specialized repair activity) is the lowest level that can do complete repair of the item.
D	-Depot is the lowest level that can do complete repair of the item.
z	-Nonrepairable. No repair is authorized.
B	-No repair is authorized. (No parts or special tools are authorized for the maintenance of a B-coded item). However, the item may be reconditioned by adjusting, lubricating, etc., at the user level.

(3) Recoverability code. Recoverability codes are assigned to items to indicate the disposition action on unserviceable items. The recoverability code is entered in the fifth position of the SMR Code as follows:

Recoverability Codes	Application/Explanation
Z	-Nonrepairable item. When unserviceable, condemn and dispose of the item at the level of maintenance shown in 3d position of SMR Code.
O	-Reparable item. When uneconomically repairable, condemn and dispose of the dem at unit or aviation unit level.
F	-Reparable item. When uneconomically repairable, condemn and dispose of the item at the direct support or aviation intermediate level.
H	-Reparable item. When uneconomically repairable, condemn and dispose of the item at the general support level.
D	-Reparable item. When beyond lower level repair capability, return to depot. Condemnation and disposal of item not authorized below depot level.
L	-Reparable item. Condemnation and disposal not authorized below specialized repair activity (SRO).
A	-Item requires special handling or condemnation procedures because of specific reasons (e.g.,predous metal content, high dollar value, critical material, or hazardous material). Refer to appropriate manuals/directives for specific instructions.

c. CAGEC (Column (3)). The Commercial and Government Entity Code (CAGEC) is a 5-digit numeric code which is used to identify the manufacturer, distributor, or Government agency, etc., that supplies the item.

d. PART NUMBER (Column (4)). Indicates the primary number used by the manufacturer (individual, company, firm, corporation, or Government activity), which controls the design and characteristics of the item by means of its engineering drawings, specifications standards, and inspection requirements to identify an Rem or range of items.

**NOTE:** When you use a NSN to requisition an Rem, the item you receive may have a different part number from the part ordered.

e. DESCRIPTION AND USABLE ON CODE (UOC) (Column (5)). This column induces the following information.

- (1) The Federal item name and, when required, a minimum description to identify the item.
- (2) Spare/repair parts that make up assembled item are listed immediately following the assembled item line entry.
- (3) Part numbers for bulk materials are referenced in this column in the line Rem entry for the item to be manufactured/fabricated.
- (4) The statement "END OF FIGURE" appears just below the last item description in Column 5 for given figure.

f. QTY (Column (6)). The QTY (quantity per figure column) indicates the quantity of the item used in the breakout shown on the illustration figure, which is prepared for a functional group, subfunctional group, or an assembly. A "V" appearing in this column in lieu of a quantity indicates that the quantity is variable and the quantity may vary from application to application.

**F4 EXPLANATION OF COLUMNS (SECTION IV).**a. NATIONAL STOCK NUMBER (NSN) INDEX.

(1) STOCK NUMBER column. This column lists the NSN by National Item Identification Number (NIIN) NSN sequence. The NIIN consists of the last nine digits of the NSN (i.e., 5305-01-674-1467). When using this NIIN column to locate an item, ignore the first 4 digits of the NSN. However, the complete NSN should be used when ordering items by stock number.

(2) FIG. column. This column lists the number of the figure where the item is identified/located. The figures are in numerical order in Section II and Section III.

(3) ITEM column. The item number identifies the item associated with the figure listed in the adjacent FIG. column. This item is also identified by the NSN listed on the same line.

b. PART NUMBER INDEX. Part numbers in this index are listed by part number in ascending alphanumeric sequence (i.e., vertical arrangement of letter and number combination which places the first letter or digit of each group in order A through Z, followed by the numbered 0 through 9 and each following letter or digit in like order).

(1) CAGEC column. The commercial and Government Entity Code (CAGEC) is a 5-digit numeric code used to identify the manufacturer, distributor, or Government agency, etc., that supplies the Rem.

(2) PART NUMBER column. Indicates the primary number used by the manufacturer (individual, firm, corporation, or Government activity), which controls the design and characteristics of the item or range of items.

(3) STOCK NUMBER column. This column lists the NSN for the associated part number and manufacturer identified in the PART NUMBER and CAGEC columns to the left.

(4) FIG. column. This column lists the number of the figure where the item is identified/located in Section II and II.

(5) ITEM column. The item number is that number assigned to the item as it appears in the figure referenced in the adjacent figure number column.

c. FIGURE AND ITEM NUMBER INDEX.

(1) FIG column. This column lists the number of the figure where the item is identified located in Section II and II.

(2) ITEM column. The item number is that number assigned to the item as it appears in the figure referenced in the adjacent figure number column.

(3) STOCK NUMBER column. This column lists the NSN for the Rem.

(4) CAGEC column. The Commercial and Government Entity Code (CAGEC) is a 5-dig numeric code used to identify the manufacturer, distributor, or Government agency, etc., that supplies the item.

(5) PART NUMBER column. Indicates the primary number used by the manufacturer (individual, firm, corporation, or Government activity), which controls the design and characteristics of the item by means of its engineering drawings, specifications standards, and inspection requirements to identify an item or range of items.



**F.5 SPECIAL INFORMATION.** Not applicable.

**F.6 HOW TO LOCATE REPAIR PARTS.**

a. When National Stock Number or Part Number is Not Known.

(1) First. Using the table of contents, determine the assembly group or subassembly group to which the item belongs. This is necessary since figures are prepared for assembly groups and subassembly groups, and listings are divided into the same groups.

(2) Second. Find the figure covering the assembly group or subassembly group to which the item belongs.

(3) Third. Identify the item on the figure and use the Figure and Item Number Index to find the NSN.

b. When National Stock Number or Part Number is Known.

(1) First. Using the National Stock Number of the Part Number Index, find the pertinent National Stock Number or Part Number. The NSN index is in National Item Identification Number (NIIN) sequence (see F-4.a.(1)). The part numbers in the Part Number index are listed in ascending alphanumeric sequence (see F-4.b). Both indexes cross-reference you to the illustration/figure and item number of the item you are looking for.

(2) Second. Turn to the figure and item number, verify that the item is the one you're looking for, then locate the item number in the repair parts list for the figure.

**F.7 ABBREVIATIONS.** Abbreviations used in this manual are listed in MIL-STD-12.

SECTION II. REPAIR PARTS LIST

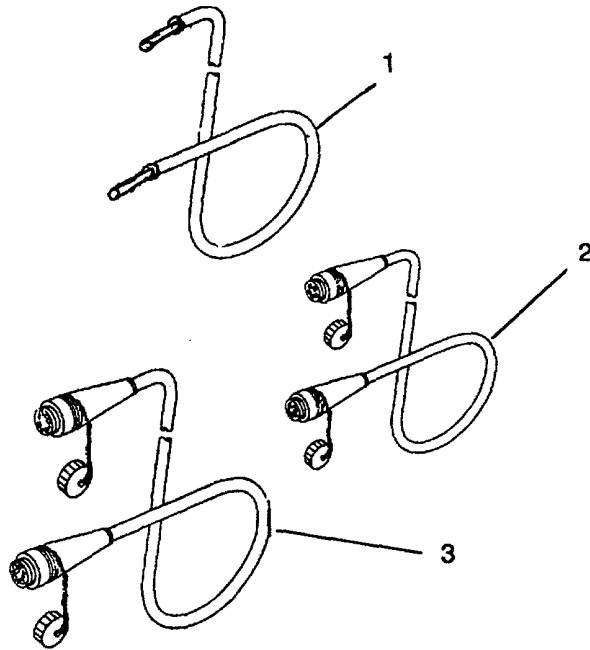
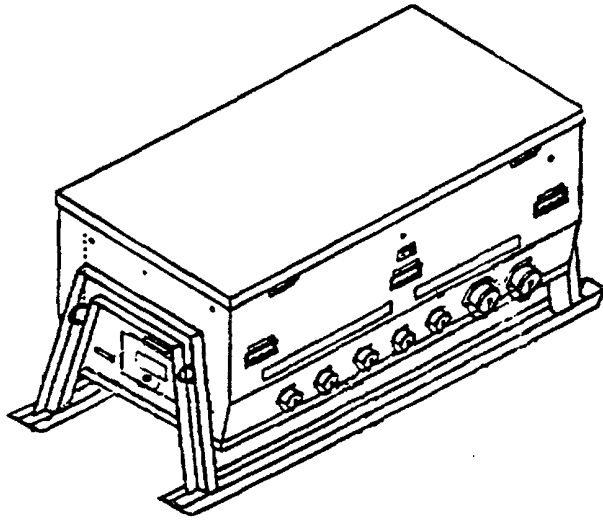

Figure F-1. Power Distribution Panel.

(F-7 Blank)/F-8

SECTION II.

(1) ITEM NO.	(2) SMR CODE	(3) CAGEC	(4) PART NUMBER	(5) DESCRIPTION AND USABLE ON CODES (UOC)	(6) QTY
				GROUP 00 POWER DISTRIBUTION PANEL 100KW	
				FIG. F-1 POWER DISTRIBUTION PANEL	
	PFFFF	98749	8642622	POWER DISTRIBUTION PANEL..... SEE FIG F-2 thru F-10 FOR BREAKDOWN	1
1	PAFZZ	81349	MS9184/1-02	CABLE ASSEMBLY, POWER ELECTRICAL, INPUT, SET OF FIVE	2
2	PAFFF	81349	M29184/3-02	CABLE ASSEMBLY, POWER ELECTRICAL, 100 FT (60Amp) SEE FIG F-11 FOR BREAKDOWN	10
3	PAFFF	81349	MS9184/2	CABLE ASSEMBLY POWER ELECTRICAL, 50 FT (100 Amp)..... SEE FIG F-12 FOR BREAKDOWN	4
				END OF FIGURE	

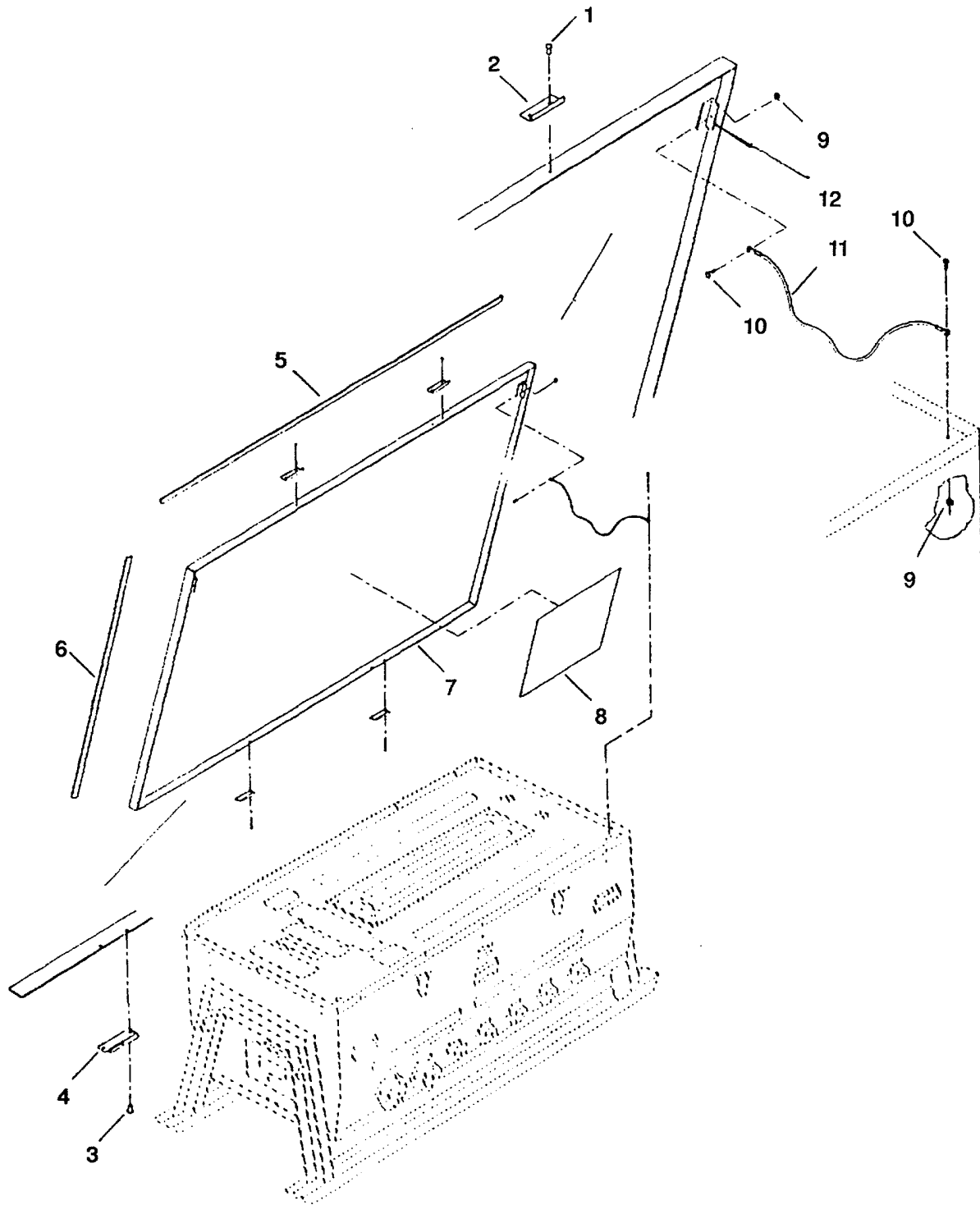

Figure F-2. Top Cover and Restraining Cable.

SECTION II.

(1) ITEM NO.	(2) SMR CODE	(3) CAGEC	(4) PART NUMBER	(5) DESCRIPTION AND USABLE ON CODES (UOC)	(6) QTY
				GROUP 01 TOP COVER ASSEMBLY FIG F-2. TOP COVER AND RESTRAINING CABLE	
1	XDOFF PAFZZ	98749 96906	8642530 MS20470A6-6	TOP COVER ASSY ..... RIVET, SOLID .....	1 4
2	PAFZZ	82240	2-25-0009402	LATCH.....	2
3	PAFZZ	96906	MS20470A5-5	.RIVET, SOLID .....	4
4	PAFZZ	03007	86786-0788	.HINGE, BUTT .....	2
5	PAOZZ	98749	76130PIS-4	.GASKET .....	V
6	PAOZZ	98749	76130PIS-5	.GASKET .....	V
7	XDOZZ	98749	8642531	.COVER ASSY .....	1
8	MDFZZ	98749	8642625	SCHEMATIC PLATE.....	1
9	PAOZZ	96906	MS21044CO8	NUT, SELF-LOCKING, HEX .....	4
10	PAOZZ	96906	MS51957-45	SCREW, MACHINE .....	4
11	PAOZZ	51511	24190	CABLE, RESTRAINING ASSEMBLY	2
12	XDFZZ	98749	8642388	BRACKET, ANGLE .....	2
				END OF FIGURE	

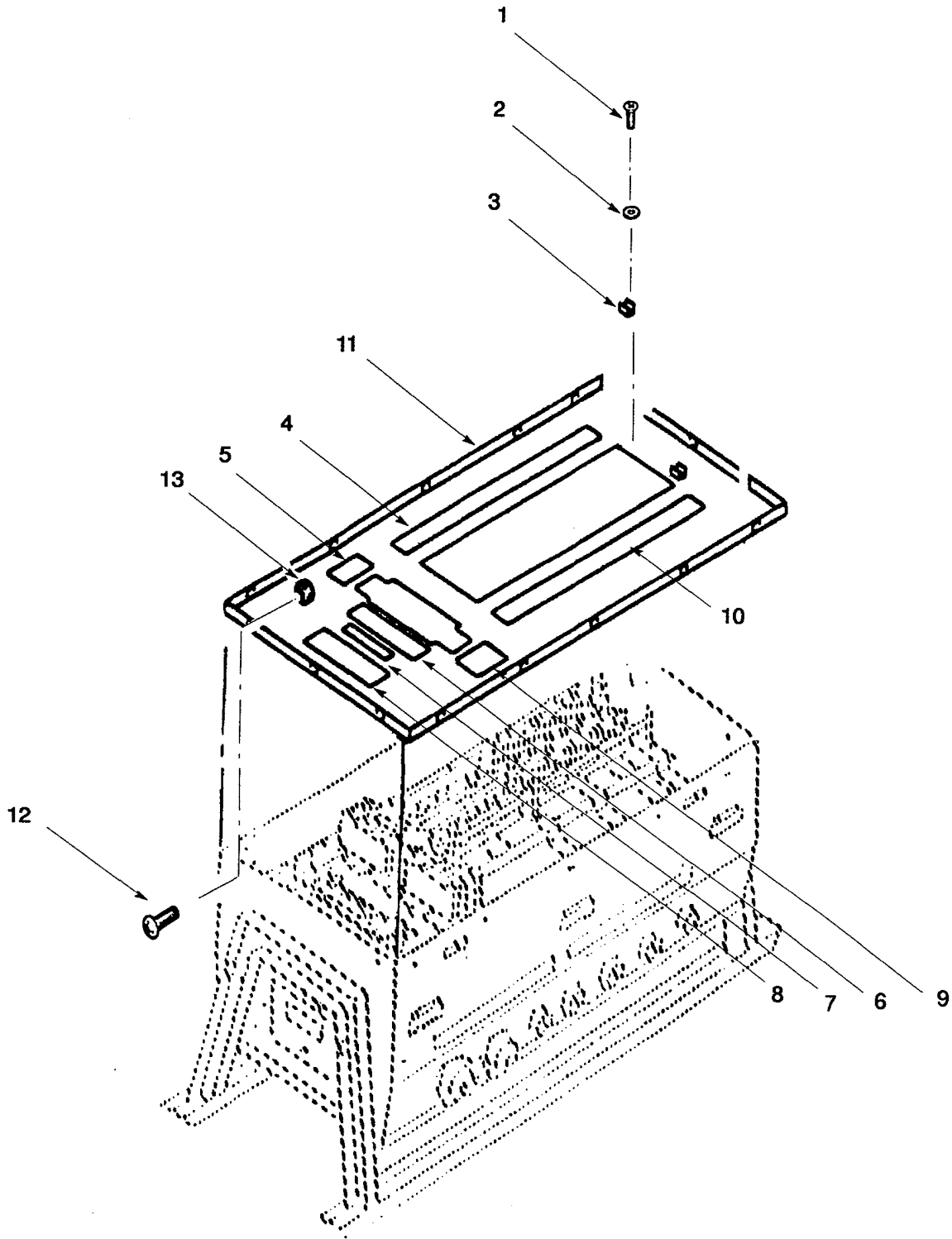

Figure F-3. Deadfront Panel Assembly.

SECTION II.

(1) ITEM NO	(2) SMR CODE	(3) CAGEC	(4) PART NUMBER	(5) DESCRIPTION AND USABLE ON CODES (UOC)	(6) QTY
GROUP 02 PANEL ASSEMBLY, DEADFRONT					
FIG F-3. DEADFRONT PANEL ASSEMBLY					
1	XDFFF	98749	8642628	DEADFRONT PNL ASSY .....	1
2	PAOZZ	96906	MS51957-77	.SCREW, MACHINE .....	2
3	PAOZZ	96906	MS35333-74	.WASHER, LOCK .....	2
4	PAOZZ	74829	C11	.CLIP, FUSE .....	2
5	MDOZZ	98749	8642626-12	.MARKER, IDENT .....	1
6	MDOZZ	98749	8642626-14	.MARKER, IDENT .....	1
7	MDOZZ	98749	8642626-15	.PLACARD .....	1
8	MDOZZ	98749	8642626-9	.MARKER, IDENT .....	1
9	MDOZZ	98749	8642626-7	.PLACARD .....	1
10	MDOZZ	98749	8642626-10	.MARKER, IDENT .....	1
11	MDOZZ	98749	8642626-11	.MARKER, IDENT .....	1
12	XDFZZ	98749	8642650	.PANEL, BLANK .....	1
13	PAOZZ	96906	MS51958-62	SCREW, HEX HEAD, 10-32 X 1/2.....	16
	PAOZZ	96906	MS21044C3	NUT, SELF, LOCKING 10-32.....	16
END OF FIGURE					

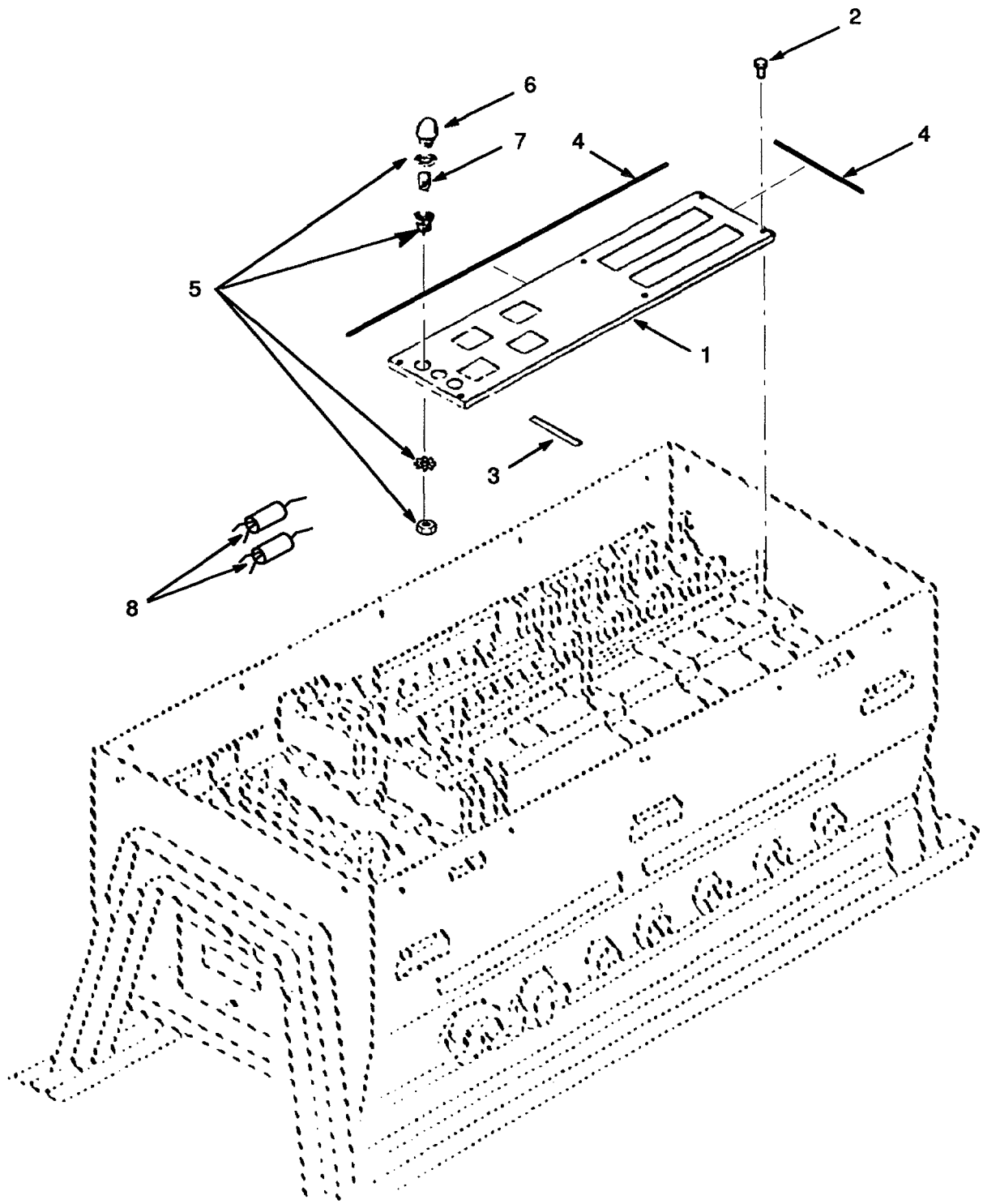

Figure F-4. Subpanel, Indicator Light Assy, Indicator Bulb, and Circuit Breakers (Sheet 1 of 3).



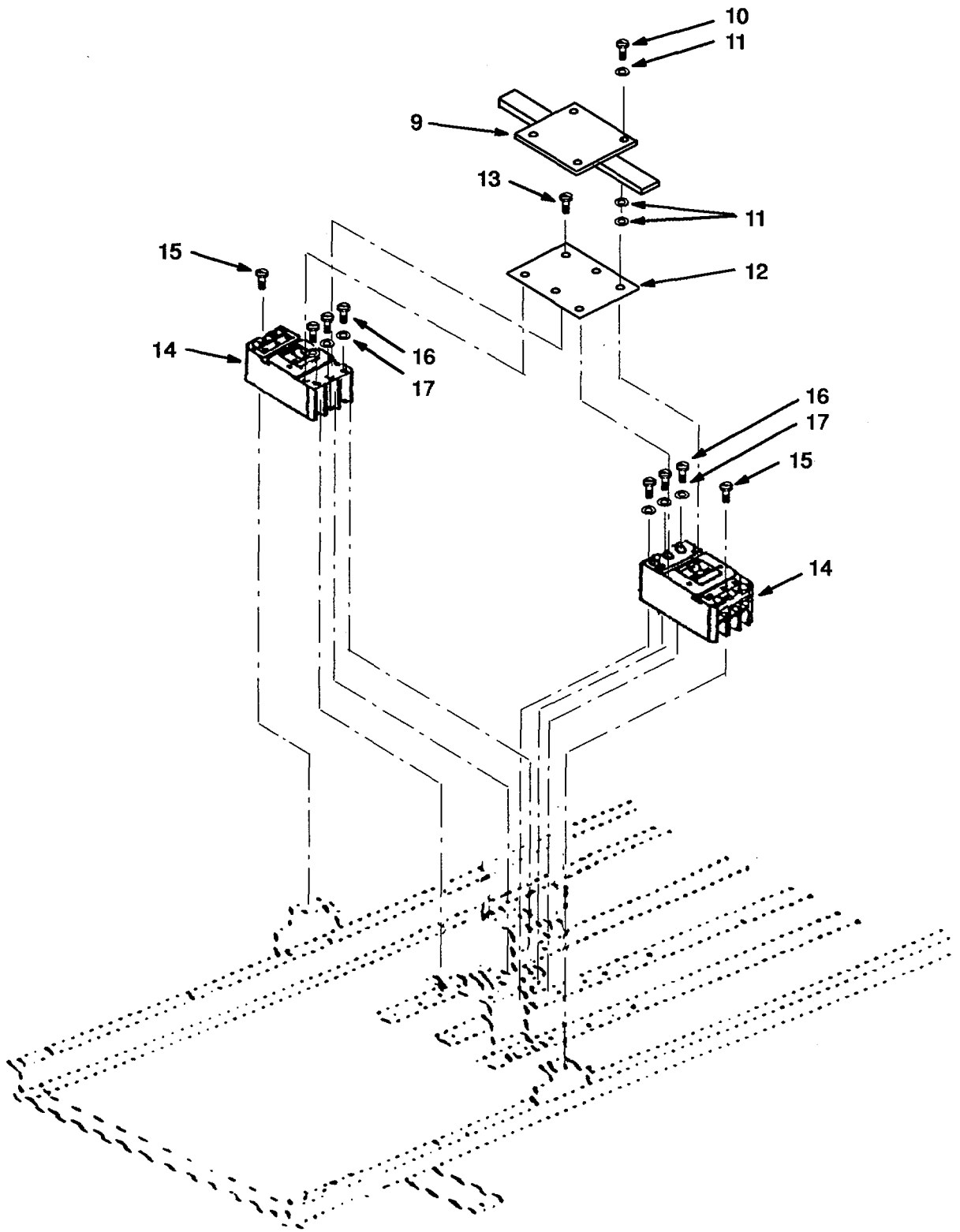

Figure F-4. Subpanel, Indicator Light Assy, Indicator Bulb, and Circuit Breakers (Sheet 2 of 3).

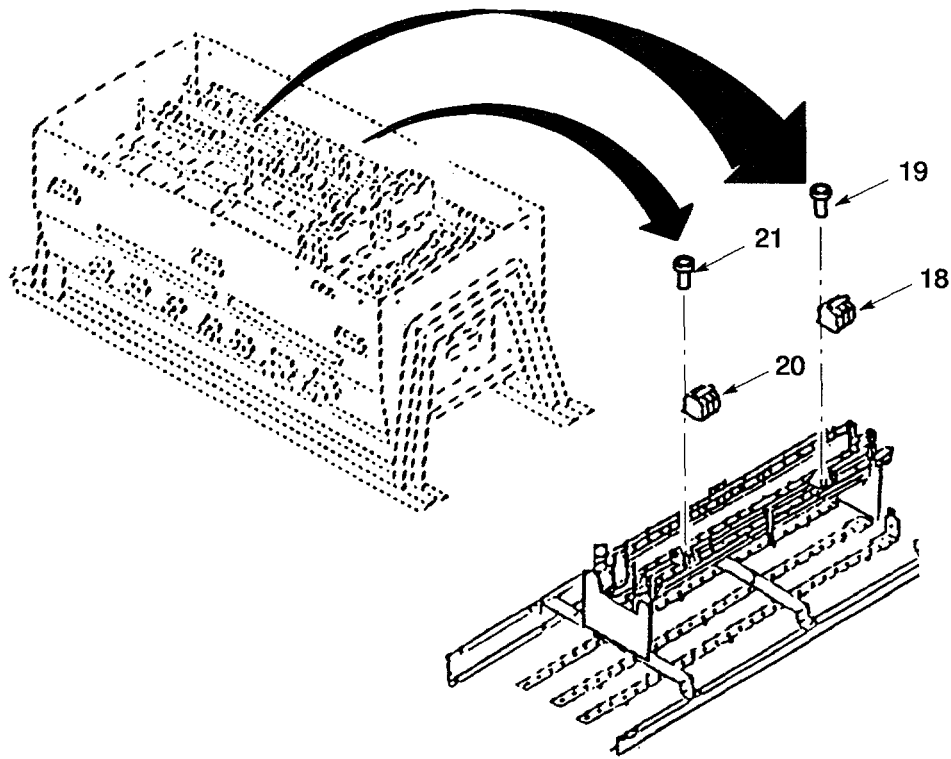

Figure F-4. Subpanel, Indicator Light Assy, Indicator Bulb, and Circuit Breakers (Sheet 3 of 3).

SECTION II.

(1) ITEM NO	(2) SMR CODE	(3) CAGEC	(4) PART NUMBER	(5) DESCRIPTION AND USABLE ON CODES (UOC)	(6) QTY
				GROUP 03 SUBPANEL, INDICATOR LIGHT ASSY INDICATOR BULB, (ITEMS 1-13)	
				GROUP 04 CIRCUIT BREAKERS (ITEMS 14-21)	
				FIG. F-4 SUBPANEL, INDICATOR LIGHT ASSY, INDICATOR BULB AND CIRCUIT BREAKERS	
1	XDOZZ	98749	8642654	PANEL, SUB, BLANK .....	1
2	PAOZZ	96906	MS5197-64	SCREW, MACHINE .....	6
3	PAOZZ	98749	8642626-13	MARKER, IDENT .....	1
4	PAOZZ	0E8J0	1010-2	EDGE TRIM .....	V
5	PAOZZ	81349	LH76/3	LIGHT, INDICATOR .....	3
6	PAOZZ	81349	LC14GN3	LENS, LIGHT .....	3
7	PAOZZ	92966	120MB	LAMP, INCANDESCENT .....	3
8	PAOZZ	96906	MIL-1631D	INSULATION, TUBING, ELECTRICAL .....	V
9	PAOZZ	98749	7503A77G01	INTERLOCK .....	1
10	PAOZZ	96906	MS51957-86	SCREW, PAN HEAD 1/4-20 X 1-3/4 .....	4
11	PAOZZ	96906	MS15795-810	WASHER, FLAT 14 .....	12
12	XDFZZ	98749	8642556	PLATE, MENDING .....	1
13	PAOZZ	96906	MS51957-28	SCREW, MACHINE .....	4
14	PAFZZ	89946	KD3400	CIRCUIT BREAKER (400 Amp) .....	2
15	PAFZZ	96906	MS51957-85	SCREW, PAN HEAD 1/4-20 X 1-1/2 .....	4
16	PAFZZ	89946	70041GA095	BOLT, MOUNTING (AP) .....	6
17	PAFZZ	89946	22D9175H04	WASHER .....	6
18	PAOZZ	89946	QBHW3060H	CIRCUIT BREAKER (60 AMP) .....	10
19	PAOZZ	96906	MS51958-64	SCREW, MACHINE .....	30
20	PAOZZ	89946	QBHW3100H	CIRCUIT BREAKER (100 AMP) .....	4
21	PAOZZ	96906	MS51958-64	SCREW, MACHINE .....	18
END OF FIGURE					

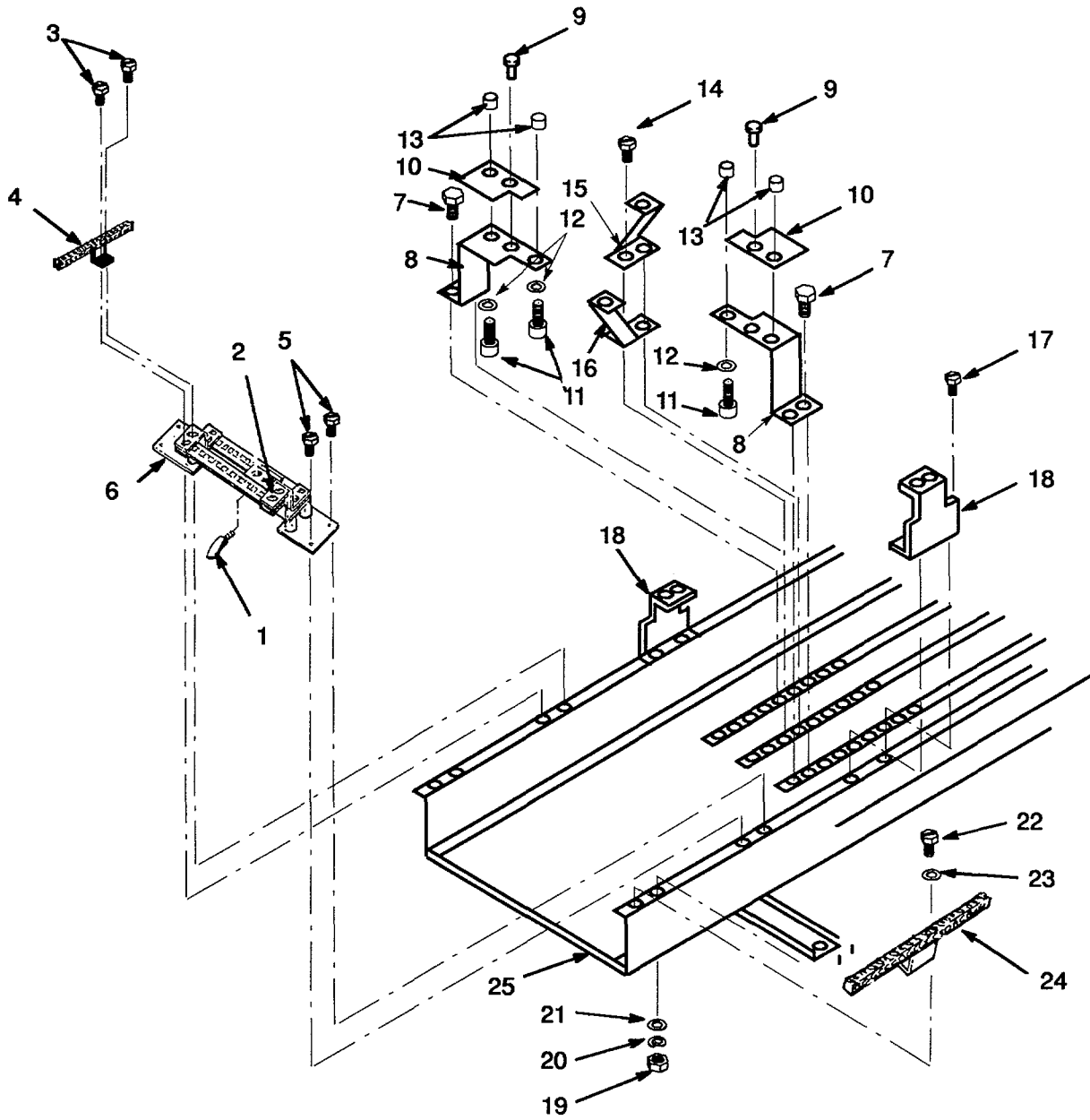

Figure F-5. Internal Panel Board Assembly (Sheet 1 of 3).

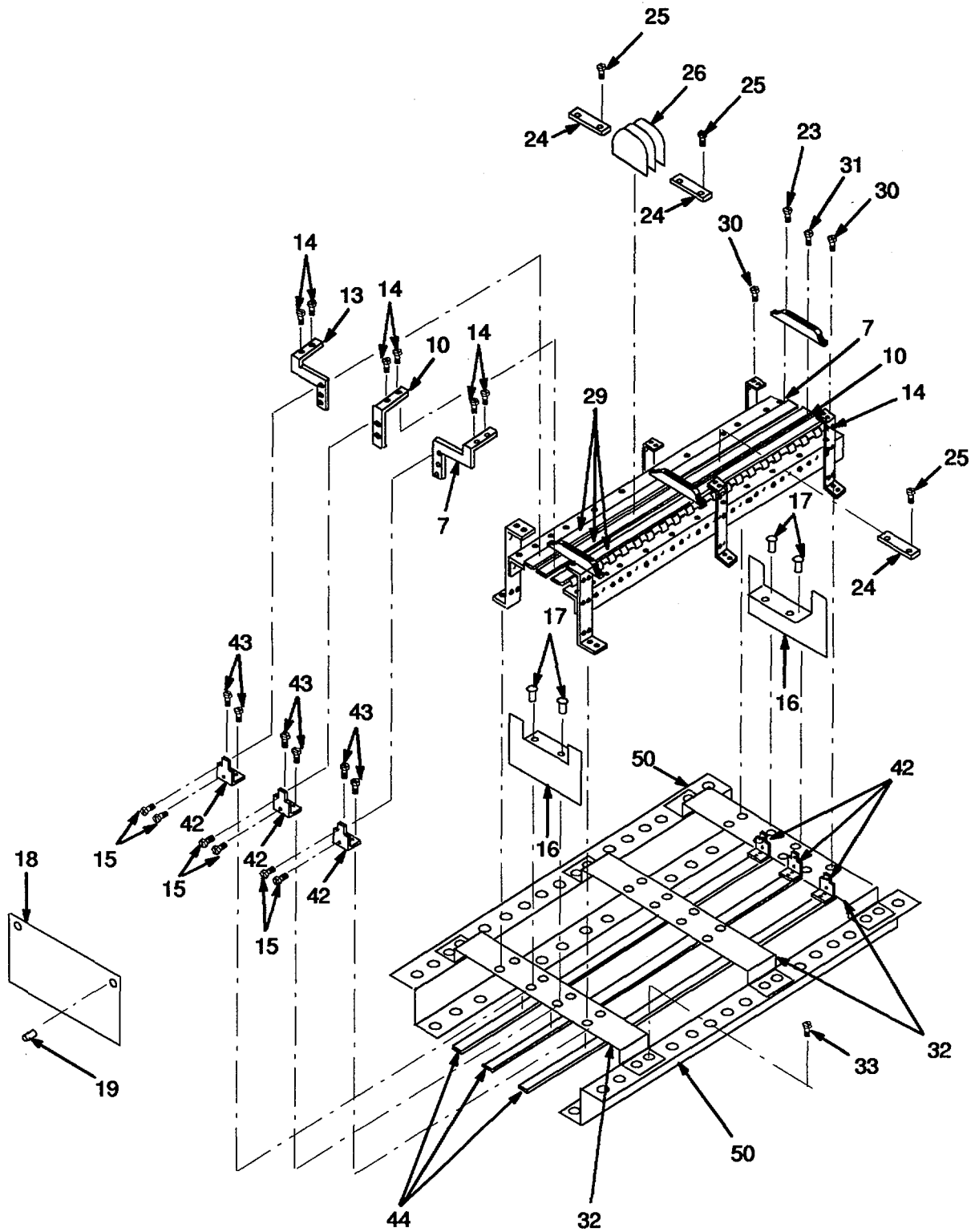

Figure F-5. Internal Panel Board Assembly (Sheet 2 of 3).

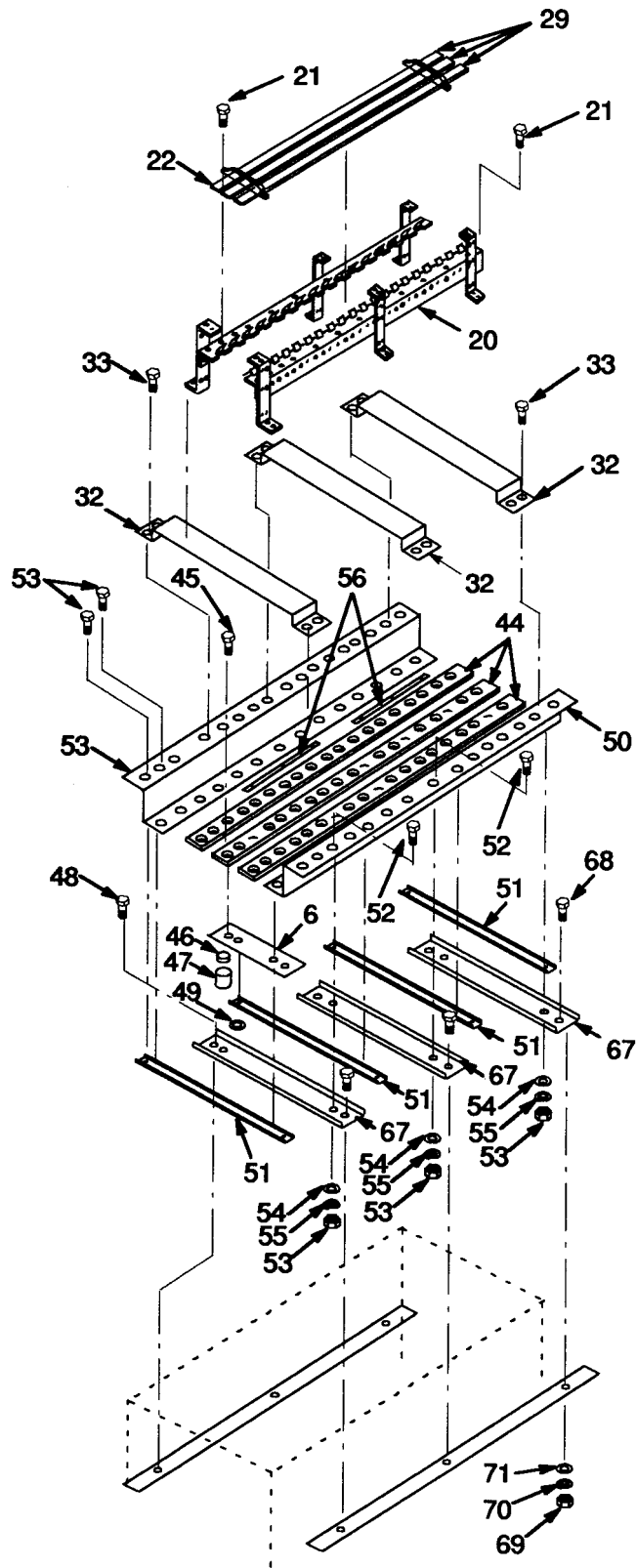

Figure F-5. Internal Panel Board Assembly (Sheet 3 of 3).

SECTION II.

(1) ITEM NO	(2) SMR CODE	(3) CAGEC	(4) PART NUMBER	(5) DESCRIPTION AND USABLE ON CODES (UOC)	(6) QTY
				GROUP 05 INTERIOR PANEL BOARD ASSEMBLY	
				FIG. F-5 INTERIOR PANEL BOARD ASSEMBLY	
				PANELBOARD INT. ASSEMBLY, 100 KW .....	Ref
1	AFFFF	98749	8642649	..PANELBOARD INTERIOR.....	1
2	AFFFF	82640	TA50220	..MOUNTING BOLTS.....	4
3	PAFZZ	89946	70041GA095	..WASHER.....	4
4	PAFZZ	89946	22D9175804	..NUT, PRESS.....	2
5	PAFZZ	89946	748A050H18	..CONNECTOR SPACER PAD.....	4
6	XDFZZ	89946	5079A04H01	..INSULATION, CONNECTOR.....	3
7	XDFZZ	89946	5079A20H01	..SUB BUS CONDUCTOR, PHASE A.....	2
8	PAFZZ	96906	5078A57H01	..SCREW, 10-32 X 3/4" (AP).....	4
9	PAFZZ	96906	MS51958-65	..SCREW, FLAT HEAD, 1/4-20 X 1/2.....	4
10	XDFZZ	89946	MS51958-78	..SUB BUS CONDUCTOR, PHASE B.....	2
11	PAFZZ	96906	5078A58H01	..SCREW, 10-32 X 3/4" (AP).....	4
12	PAFZZ	96906	MS51959-65	..SCREW, FLAT HEAD, 1/420 X 1/2".....	4
13	XDFZZ	89946	MS51959-78	..SUB BUS CONDUCTOR, PHASE C.....	2
14	XDFZZ	89946	5078A59H01	..SCREW, 10-32 X 3/4".....	4
15	PAFZZ	96906	MS51958-65	..SCREW, FLAT HEAD, 1/4-20 X 1/2".....	4
16	PAFZZ	96906	MS51959-78	..INSULATOR ANGLE BRACKET.....	2
17	XDFZZ	89946	5079A21H01	..RIVET, SPLIT.....	4
18	PAFZZ	89946	7499A46H01	..INSULATION, CONNECTOR.....	1
19	XDFZZ	89946	5079A20H1	..RIVET, SPLIT.....	4
20	PAFZZ	89946	7499A46H01	..BRACKET, ANGLE.....	2
21	PAFZZ	89946	5156C07H02	..BOLT, HEX, 1/4-20 X 3/4".....	6
22	PAFZZ	96906	MS35307-306	..BUS SUPPORT.....	2
23	PAFZZ	89946	5156C01 H01	..SCREW, 10-32 X 1-1/4".....	4
24	PAFZZ	96609	MS51958-66	..BUS CONDUCTOR, PHASE A AND B.....	8
25	PAFZZ	89946	3456B03H01	..SCREW, 10-32 X 5/8".....	18
26	PAFZZ	96906	MS51958-64	..ISOLATOR BLOCK.....	9
27	XDFZZ	89946	5156C03H01	..BRACKET MOUNTING.....	9
28	XDFZZ	89946	3456B04H01	..SCREW, 10-32 X 5/8".....	18
29	PAFZZ	96906	MS51958-64	..BUS CONDUCTOR, PHASE A, B AND C.....	3
30	PAFZZ	89946	3456B85H01-4	..SCREW, MACHINE, 10-32 X 1-1/41".....	4
	PAFZZ	96906	MS51958-68		

SECTION II.

(1) ITEM NO	(2) SMR CODE	(3) CAGEC	(4) PART NUMBER	(5) DESCRIPTION AND USABLE ON CODES (UOC)	(6) QTY
GROUP 05 INTERIOR PANEL BOARD ASSEMBLY (CONTINUED)					
FIG. F-5 INTERIOR PANEL BOARD ASSEMBLY (CONTINUED)					
31	PAFZZ	96906	MS51958-69	..SCREW, MACHINE 10-32 X 1-1/2" .....	2
32	PAFZZ	89946	6552C19H01	..SUB-CLASSIC BRACKET .....	3
33	PAFZZ	96906	MS65307-306	..BOLT, HEX, 1/4-20 X 3/4" .....	6
34	XDFZZ	89946	6552CIOH01	..MOUNTING BRACKET .....	2
35	PAFZZ	96906	MS35307-306	BOLT, HEX 1/420 X 3/4 .....	4
36	PAFZZ	89946	6573C08G07	..CONNECTOR, BUS, PHASE A AND C.....	2
37	PAFZZ	96906	MS53307-308	..BOLT, HEX, 1/4-20 X 1" .....	2
38	PAFZZ	89946	5078A27H01	..CONNECTOR, BUS, PHASE B, LEFT .....	1
39	PAFZZ	89946	5078A26H01	..CONNECTOR, BUS, PHASE B, RIGHT.....	1
40	PAFZZ	89946	5079A150H1	..INSULATION, KD BREAKER.....	2
41	PAFZZ	89946	7499A46H01	..RIVET, PLASTIC .....	2
42	PAFZZ	89946	5078A56H01	..BUS BAR CONNECTOR .....	6
43	PAFZZ	96906	MS35307-308	..BOLT, HEX, 1/4-20 X 1" .....	12
44	PAFZZ	89946	6563C09H17	..MAIN BUS BAR, PHASE A, B, AND C .....	3
45	PAFZZ	96906	MS51957-78	..SCREW, MACHINE, 1/4-20 X 1/2" .....	9
46	PAFZZ	98749	8642395	..SPACER.....	9
47	XDFZZ	89946	5156C05H01	..INSULATOR .....	9
48	PAFZZ	96906	MS51957-78	..SCREW, MACHINE, 1/4-20 X 1/2" .....	9
49	PAOZZ	96906	MS15795-81	..WASHER.....	9
50	PAFZZ	89946	6550C57H01	..Z, RAIL.....	2
51	PAFZZ	89946	6552C30H01	..BRACKET, CHASSIS.....	4
52	PAFZZ	96906	MS35307-310	..BOLT, HEX, 1/420 X 1-1/4".....	6
53	PAFZZ	96906	MS35649-2254	..NUT, HEX 1/4-20 .....	6
54	PAFZZ	96906	MS15795-810	..WASHER, FLAT 1/4" .....	6
55	PAFZZ	96906	MS35333-74	..WASHER, LOCK 1/4" .....	6
56	PAFZZ	0E8J0	1010-1	..EDGE TRIM 48" .....	V
57	PAFZZ	82640	5156C05G03	..BUS BAR, GRD .....	1
58	PAFZZ	96906	MS35307-306	..BOLT, 114-20 X 3/4" .....	2
59	PAFZZ	82640	5156C05G03	..BUS BAR, NEUTRAL.....	1
60	PAFZZ	96906	MS51958-65	..SCREW, 10-32 X 3/4" .....	2
61	PAFZZ	96906	MS15795-842	..WASHER, FLAT #10.....	4



SECTION II.

(1) ITEM NO	(2) SMR CODE	(3) CAGEC	(4) PART NI IMPRF	(5) DESCRIPTION AND USABLE ON CODES (UOC)	(6) QTY
GROUP 05 INTERIOR PANEL BOARD ASSEMBLY (CONTINUED)					
FIG. F-5 INTERIOR PANEL BOARD ASSEMBLY (CONTINUED)					
62	PAFZZ	96906	MS35333-73	..LOCKWASHER .....	2
63	PAFZZ	96906	MS35650-304	..NUT, 10-32 .....	2
64	PAFZZ	89946	5158C03G0	..BRACKET, NEUTRAL BUS BAR .....	1
65	PAFZZ	96906	MS51958-65	..SCREW, MACHINE 10-32 X 3/4" .....	2
66	PAFZZ	96906	MS35333-73	..WASHER, LOCK, 10-32 .....	2
67	XDFZZ	98749	8642535	..MOUNTING RAIL .....	3
68	PAFZZ	96906	MS35307-334	..BOLT, HEX 5116-18 .....	6
69	PAFZZ	96906	MS51971-2	..NUT, HEX 5/16 .....	6
70	PAFZZ	96906	MS35333-75	..WASHER, LOCK 5/16 .....	6
71	PAFZZ	96906	MS15795-812	..WASHER, FLAT 5/16 .....	6
END OF FIGURE					

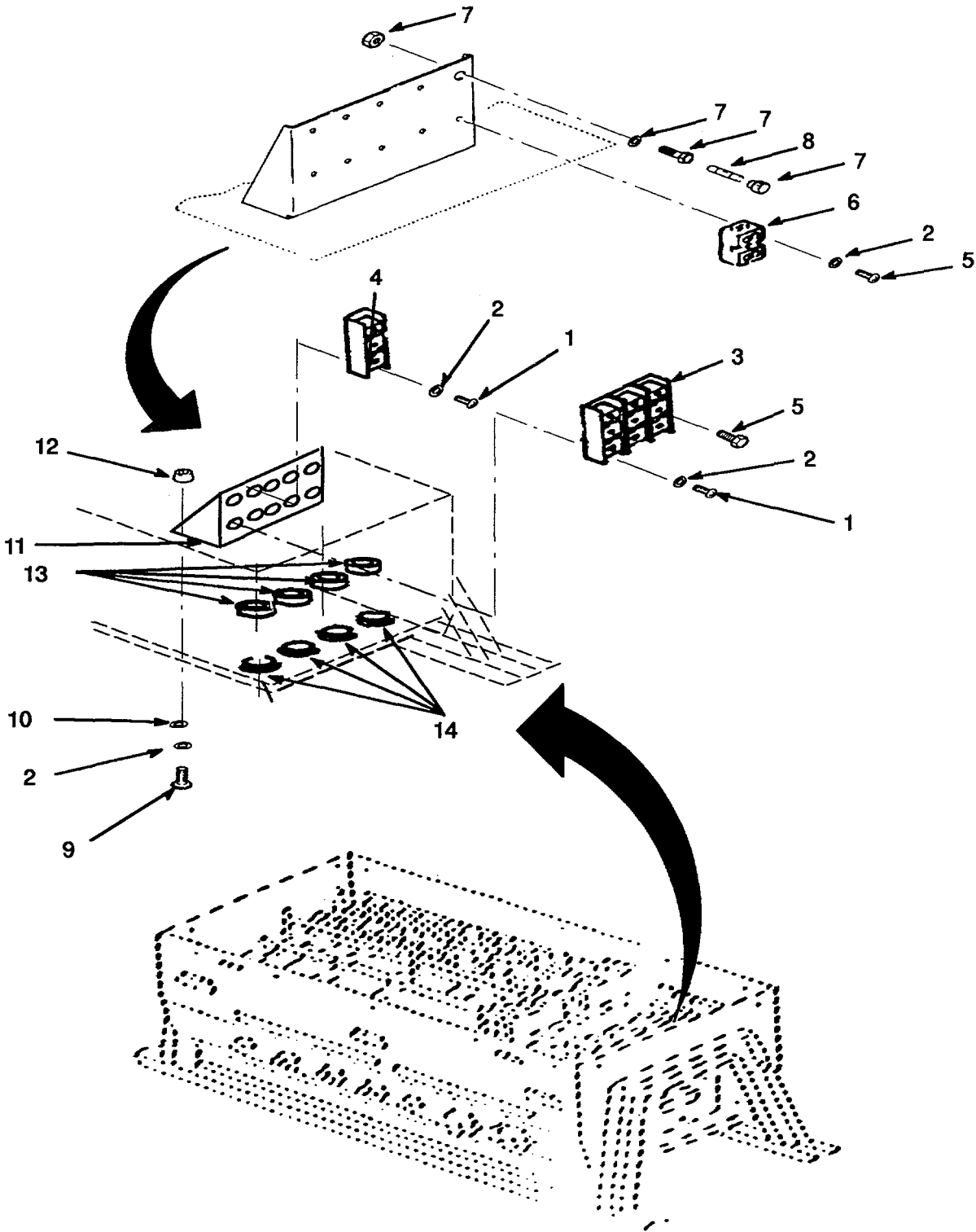

Figure F-6. Terminal Blocks, Fuse Holder, and Fuse.

SECTION II.

(1) ITEM NO	(2) SMR CODE	(3) CAGEC	(4) PART NUMBER	(5) DESCRIPTION AND USABLE ON CODES (UOC)	(6) QTY
				GROUP 06 TERMINAL BLOCKS (ITEMS 1-6)	
				GROUP 07 FUSE HOLDER (ITEMS 7-14)	
				FIG. F-6 TERMINAL BLOCKS, FUSE HOLDER, AND FUSE	
	PAOZZ	98749	8642559	TERMINAL BLOCK ASSY .....	2
1	PAOZZ	96906	MS51957-83	. SCREW, MACHINE .....	16
2	PAOZZ	96906	MS35333-74	. WASHER, LOCK .....	26
3	PAOZZ	74829	PDB-22-350-3	. TERMINAL BLOCK 3-POLE .....	2
4	PAOZZ	74829	PDB-22-350-1	. TERMINAL BLOCK 1-POLE .....	2
5	PAOZZ	96906	MS51957-84	. SCREW, MACHINE .....	10
6	PAOZZ	78429	D-20388-1	. TERMINAL BLOCK GRD .....	2
7	PAOZZ	81349	FHN26G1	. FUSE HOLDER .....	2
8	PAOZZ	81349	F02A250V2A	. FUSE .....	2
9	PAOZZ	96906	MS35307-306	. SCREW, MACHINE .....	8
10	PAOZZ	96906	MS15795-81	. WASHER, FLAT .....	8
11	XDOZZ	98749	8642539	. BRACKET .....	3
12	PAOZZ	46384	CLS-4420-3	. NUT, CLINCH .....	26
13	PAOZZ	28520	2420	. BUSHING, ENTRY .....	8
14	PAOZZ	28520	2783	. COVER, DUST .....	8
				END OF FIGURE	

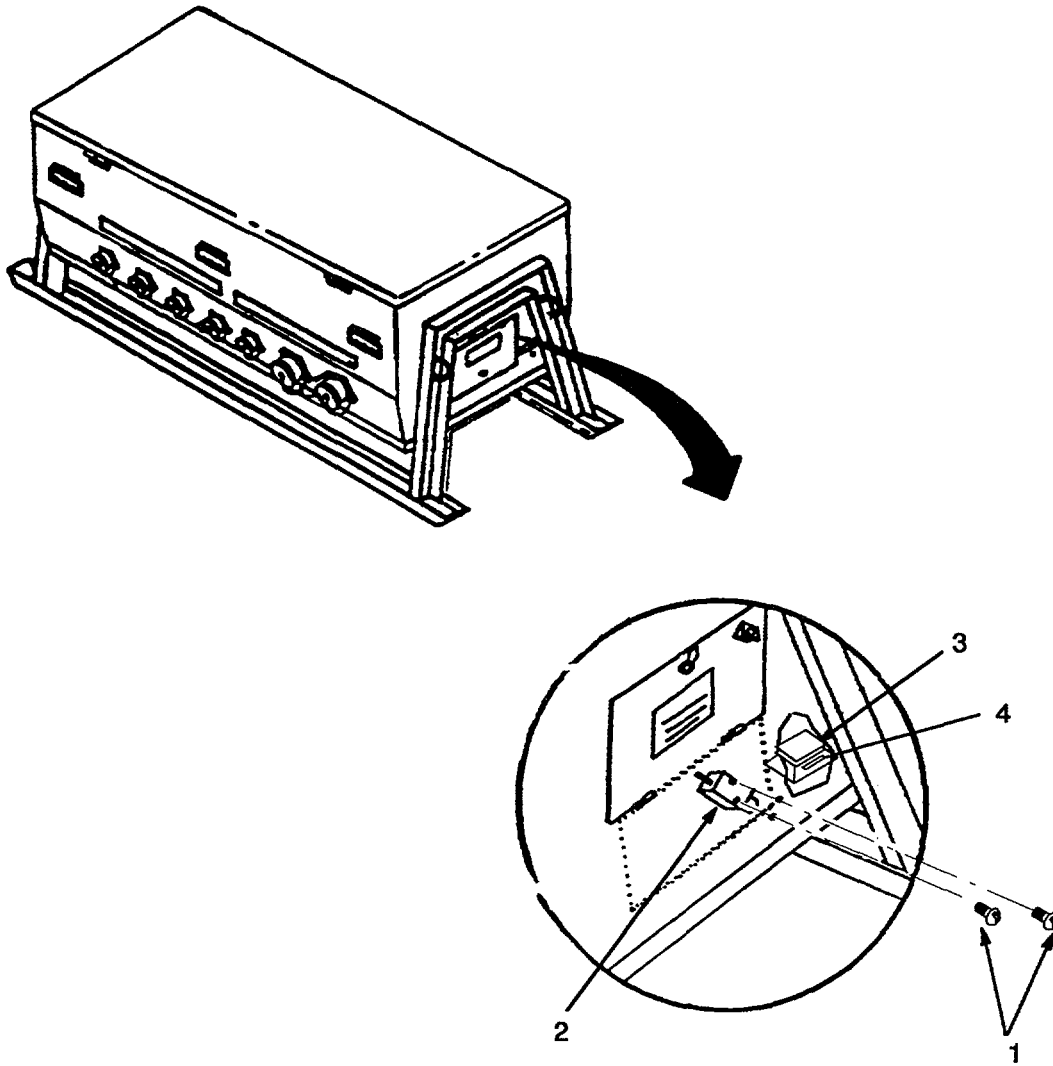

Figure F-7. Solenoid Interlock.

SECTION II.

(1) ITEM NO	(2) SMR CODE	(3) CAGEC	(4) PART NUMBER	(5) DESCRIPTION AND USABLE ON CODES (UOC)	(6) QTY
1	PAOZZ	96906	MS51957-42	<p>GROUP 08 SOLENOID, INTERLOCK</p> <p>FIG. F-7 SOLENOID INTERLOCK</p> <p>TERMINAL BLOCK ASSY.....</p>	4
2	PAOZZ	27190	940-4498	SCREW, MACHINE .....	2
3	PAOZZ	98749	8642404	SOLENOID, INTERLOCK .....	2
4	PAOZZ	96906	MS3367-49	HOLDER, CABLE TIE .....	2
				STRAP, TIE DOWN .....	V
				END OF FIGURE	

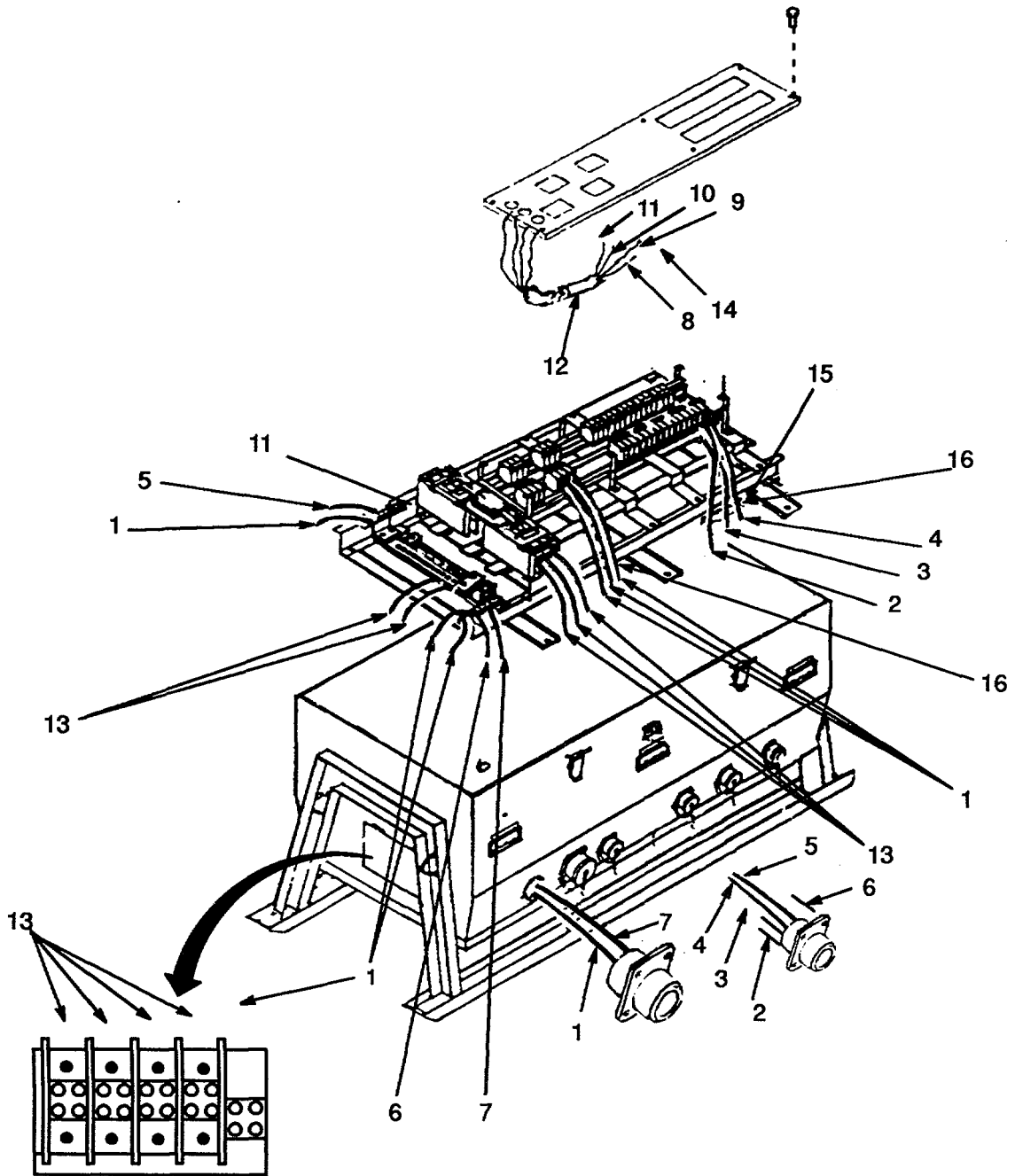

Figure F-8. Electrical Leads.

SECTION II.

(1) ITEM NO	(2) SMR CODE	(3) CAGEC	(4) PART NUMBER	(5) DESCRIPTION AND USABLE ON CODES (UOC)	(6) QTY
GROUP 09 LEADS, ELECTRICAL					
FIG. F-8 ELECTRICAL LEADS					
1	XDFZZ	98749	8642402-1	WIRE, ELECTRICAL, 2 AWG, BLACK,..... MAKE FROM M5086/2-2-0	V
2	XDFZZ	98749	8642402-3	WIRE ELECTRICAL, 6 AWG, BLACK,..... MAKE FROM M5086/2-6-0	V
3	XDFZZ	98749	8642402-4	WIRE ELECTRICAL, 6 AWG, RED,..... MAKE FROM M5086/2-6-2	V
4	XDFZZ	98749	8642402-5	WIRE ELECTRICAL, 6 AWG, BLUE,..... MAKE FROM M5086/2-6-6	V
5	XDFZZ	98749	8642402-6	WIRE ELECTRICAL, 6 AWG, WHITE,..... MAKE FROM M5086/2-6-9	V
6	XDFZZ	98749	8642402-7	WIRE ELECTRICAL, 6 AWG, GREEN, ..... MAKE FROM M5086/2-6-5	V
7	XDFZZ	98749	8642402-8	WIRE ELECTRICAL, 8 AWG, GREEN,..... MAKE FROM M5086/2-8-5	V
8	XDFZZ	98749	8642402-14	WIRE ELECTRICAL, 18 AWG, BLACK,..... MAKE FROM M5086/2-18-0	V
9	XDFZZ	98749	8642402-15	WIRE ELECTRICAL, 18 AWG, RED,..... MAKE FROM M5086/2-18-3	V
10	XDFZZ	98749	8642402-16	WIRE ELECTRICAL, 18 AWG, BLUE,..... MAKE FROM M5086/2-18-6	V
11	XDFZZ	98749	8642402-17	WIRE ELECTRICAL, 18 AWG, WHITE, ..... MAKE FROM M5086/2-18-9	V
12	PAFZZ	81349	M23053/5-101-0	SLEEVING, INSULATION 35 INCHES LG .....	V
13	PAFZZ	1Y964	250MCM BLACK LWV7-700	CABLE, WELDING ELECTRICAL .....	V
14	PAFZZ	14726	SS22499F	LUG, TERMINAL.....	3
15	PAOZZ	96906	MS3367-1-9	STRAP, TIE DOWN.....	V
16	PAOZZ	96906	MS3367-3-9	STRAP, TIE DOWN.....	V
END OF FIGURE					

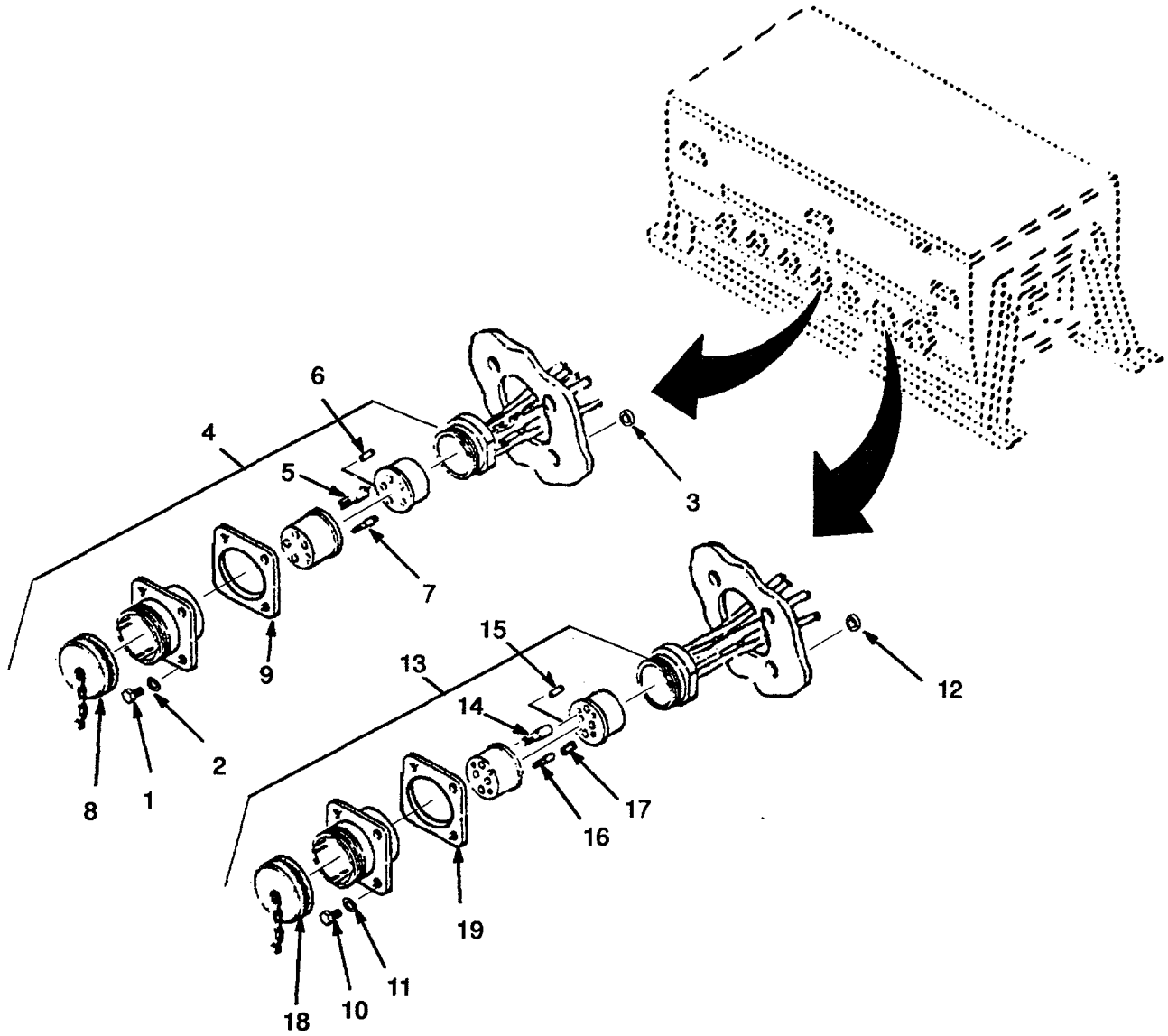

Figure F-9. Connectors.



SECTION II.

(1) ITEM NO	(2) SMR CODE	(3) CAGEC	(4) PART NUMBER	(5) DESCRIPTION AND USABLE ON CODES	(6) QTY
GROUP 10 CONNECTORS, MS					
FIG. F-9 CONNECTORS					
1	PAOZZ	96906	MS51958-65	SCREW, MACHINE .....	40
2	PAOZZ	96906	MS35333-73	WASHER, LOCK .....	40
3	PAFZZ	46384	CLSS-032-3	NUT, CLINCH .....	40
4	PAFZZ	96906	MS90555C32412S	CONNECTOR, PLUG .....	10
5	PAFZZ	81349	M39029/49-331	.CONTACT, SOCKET A, B, C AND N .....	40
6	PAFZZ	96906	MS3348-4-6L	.BUSHING, CONTACT .....	40
7	PAFZZ	81349	M9029/49-329	.CONTACT, SOCKET G .....	10
8	PAOZZ	96906	MS90563-3C	.COVER .....	10
9	PAFZZ	96906	MS52000-12	.GASKET .....	10
10	PAOZZ	96906	MS51957-82	SCREW, MACHINE .....	16
11	PAOZZ	96906	MS35333-74	WASHER, LOCK .....	16
12	PAFZZ	46384	CLS4420-3	NUT, CLINCH .....	16
13	PAFZZ	96906	MS90555C44412S	CONNECTOR, RECEPTACLE .....	4
14	PAFZZ	81349	M39029/49-333	.CONTACT, SOCKET .....	16
15	PAFZZ	96906	MS3348-1-2L	.BUSHING, CONTACT .....	16
16	PAOZZ	81349	M39029/49-330	.CONTACT, SOCKET .....	16
17	PAOZZ	96906	MS3348-6-8L	.BUSHING, CONTACT .....	16
18	PAOZZ	96906	MS90563-7C	.COVER .....	4
19	PAFZZ	77820	10-3667-48	.GASKET .....	4
END OF FIGURE					

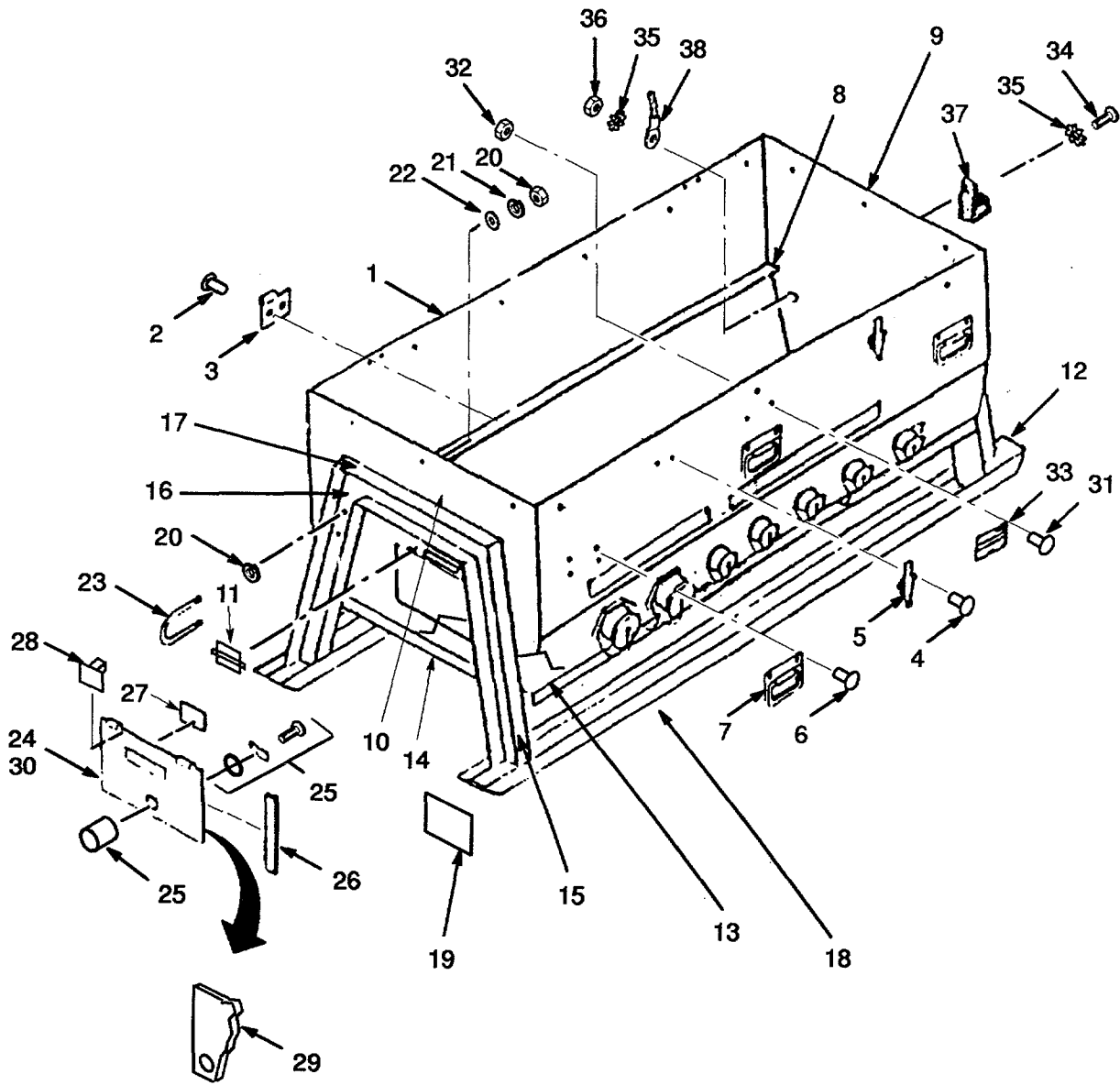

Figure F-10. Cabinet Assembly (Sheet 1 of 2).

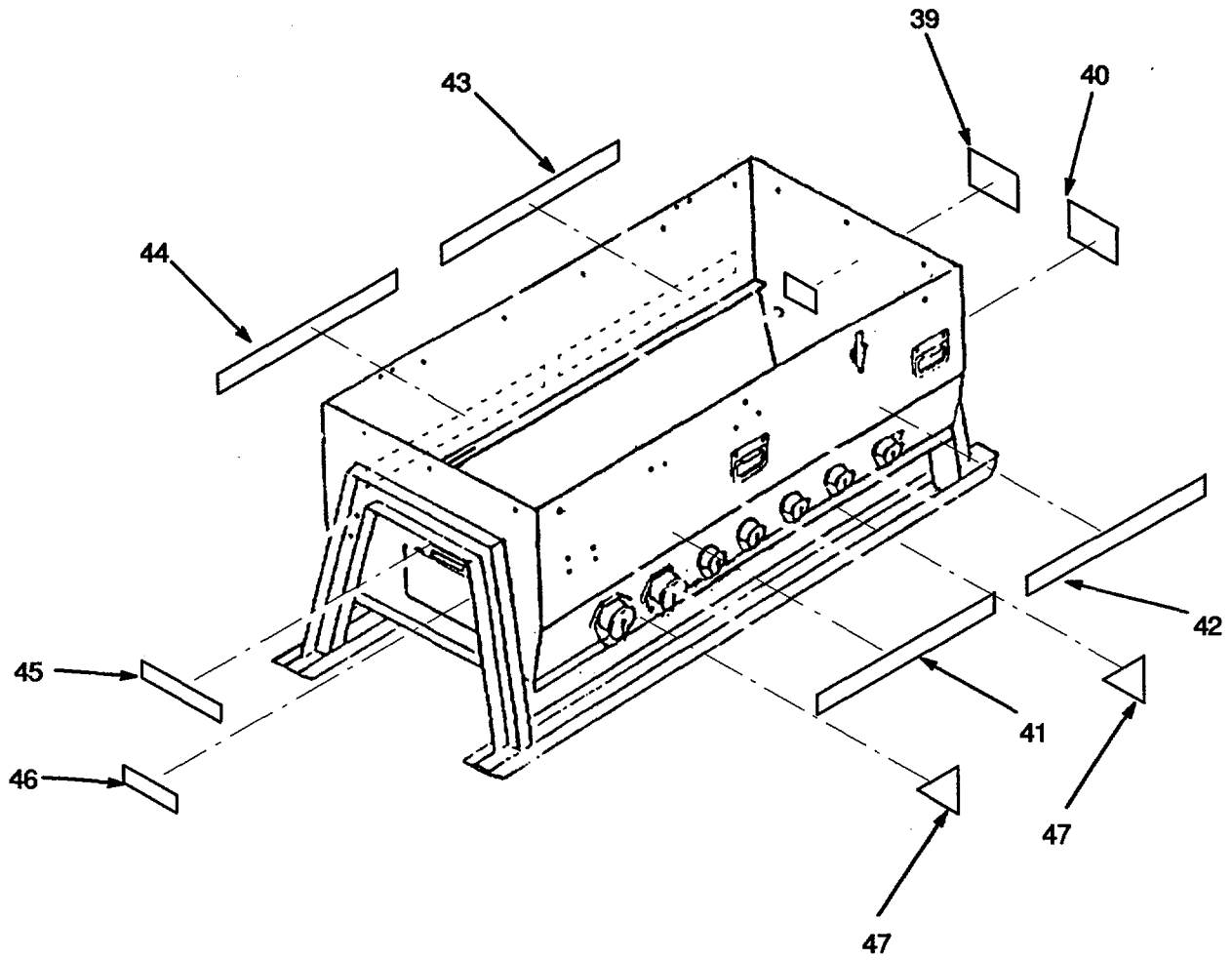

Figure F-10. Cabinet Assembly (Sheet 2 of 2).

SECTION II.

(1) ITEM NO	(2) SMR CODE	(3) CAGEC	(4) PART NUMBER	(5) DESCRIPTION AND USABLE ON CODES	(6) QTY
GROUP 11 CABINET ASSEMBLY					
FIG. F-10 CABINET ASSEMBLY					
1	XDFFF	98749	8642629	CABINET, CASE ASSY.....	1
2	PAFZZ	96906	MS20470A6-6	.RIVET, SOLID.....	4
3	PAFZZ	03007	86787-0788	.HINGE, SLIP JOINT.....	2
4	PAFZZ	96906	MS20470A5-5	.RIVET, SOLID.....	4
5	PAFZZ	82240	2-25-0006-2	.CATCH, CLAMPING.....	2
6	PAFZZ	96906	MS20470A6-8	.RIVET, SOLID.....	30
7	PAFZZ	96906	MS18012-5	.HANDLE, BAIL.....	6
8	XDFZZ	98749	8642536	.FRAME, SUPPORT.....	1
9	XDFZZ	98749	8642533-1	.PLATE, END.....	1
10	XDFZZ	98749	8642533-2	.PLATE, END.....	1
11	PAFZZ	03007	NHAL8022LM	.HINGE, LEAF BUTT.....	4
12	PAFZZ	98749	8642427	.MOUNTING BASE, ELECTRICAL.....	1
13	XAFZZ	98749	8642542-1	..RAIL.....	2
14	XAFZZ	98749	8642542-2	..SPACE.....	2
15	XAFZZ	98749	8642542-3	..LEG.....	2
16	XAFZZ	98749	86425424	..LEG.....	2
17	XAFZZ	98749	8642542-5	..TOP.....	2
18	XAFZZ	98749	86425424	...SKID.....	2
19	XAFZZ	98749	8642542-7	..CAP, SKID.....	4
20	PAOZZ	96906	MS35649-2384	.NUT, PLAIN, HEXAGON.....	16
21	PAOZZ	96906	MS35333-76	.WASHER, LOCK.....	8
22	PAOZZ	96906	MS15795-814	.WASHER, FLAT.....	8
23	PAOZZ	98749	8642552	.BOLT, U.....	4
24	PAFZZ	98749	864234	.DOOR, ACCESS ASSY.....	2
25	PAFZZ	0E8J0	1000-UH51	..LATCH, QUARTER TURN.....	2
			U142/113J23/24/99		
26	PAFZZ	98749	76130P/S-2	..GASKET, STRIP.....	V
27	MDOZZ	98749	864-2626-16	..PLACARD.....	2
28	PAFZZ	03007	NHAL8022ORF(HS)	..HINGE, SLIP JOINT.....	4
29	XDFZZ	98749	8642538	..PLATE, STRIKE.....	2
30	PAFZZ	98749	8642544	..COVER ACCESS BLANK.....	2
31	PAOZZ	96906	MS51957-15	.SCREW, MACHINE.....	4
32	PAOZZ	96906	MS21044C04	.NUT, SELF-LOCKING, HEX.....	4

SECTION II.

(1) ITEM NO	(2) SMR CODE	(3) CAGEC	(4) PART NUMBER	(5) DESCRIPTION AND USABLE ON CODES (UOC)	(6) QTY
GROUP 11 CABINET ASSEMBLY (CONTINUED)					
FIG. F-10 CABINET ASSEMBLY (CONTINUED)					
33	MDOZZ	98749	8642624	.NAMEPLATE .....	1
34	PAOZZ	96906	MS35307-308	.SCREW, CAP, HEXAGON .....	1
35	PAOZZ	96906	MS35335-61	.WASHER, LOCK .....	2
36	PAOZZ	96906	MS35649-2384	.NUT, HEX .....	1
37	PAOZZ	74829	LO-0	.GROUND LUG .....	1
38	PAOZZ	96906	MS25036-126	.TERMINAL, LUG .....	1
39	MDOZZ	98749	8642626-1	.MARKER, IDENTIFICATION .....	1
40	MDOZZ	98749	8642626-8	.MARKER, IDENTIFICATION .....	1
41	MDOZZ	98749	8642626-3	.MARKER, IDENTIFICATION .....	1
42	MDOZZ	98749	8642626-2	.MARKER, IDENTIFICATION .....	1
43	MDOZZ	98749	8642626-5	.MARKER, IDENTIFICATION .....	1
44	MDOZZ	98749	8642626-6	.MARKER, IDENTIFICATION .....	1
45	MDOZZ	98749	8642626-7	.PLACARD .....	2
46	MDOZZ	98749	8642626-8	.PLACARD .....	1
47	MDOZZ	98749	8642626-17	.PLACARD .....	4
END OF FIGURE					

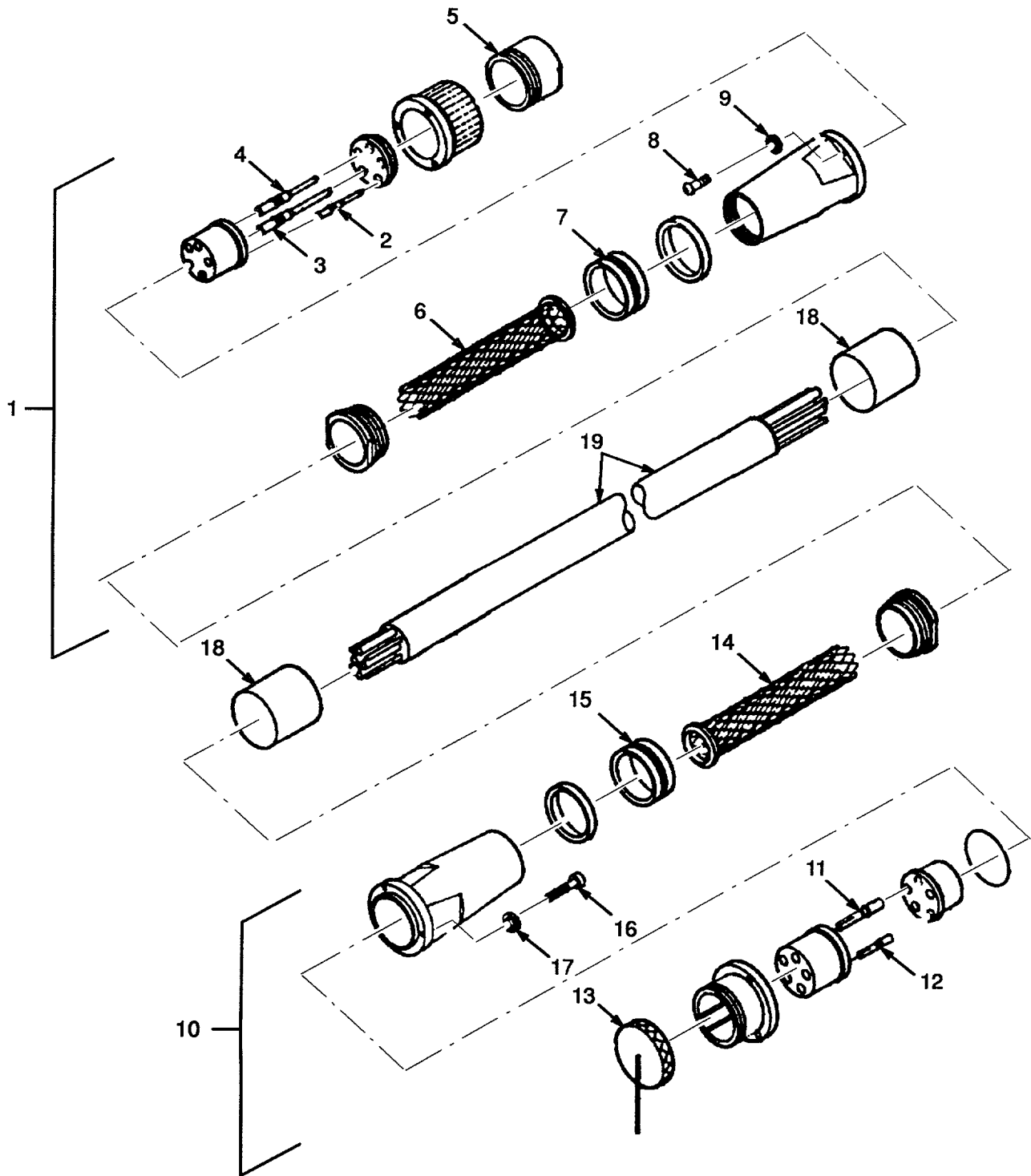

Figure F-11. 60-Amp Power Cable Assembly.

SECTION II.

(1) ITEM NO	(2) SMR CODE	(3) CAGEC	(4) PART NUMBER	(5) DESCRIPTION AND USABLE ON CODES	(6) QTY
				GROUP 12 CABLE ASSEMBLIES	
				FIG F-11 60-AMP POWER CABLE ASSY	
	AFFFF	81349	M29184/3-02	CABLE ASSY, POWER, 60-AMP ..... (USED WITH J5 THRU J14)	10
1	PAFFF	96906	MS90556-C32412P	..CONNECTOR, ELECTRICAL, PLUG.....	1
2	PAFZZ	81349	M39029/48-318	..CONTACT, PIN (GROUND) .....	1
3	PAFZZ	81349	M39029/48-321	..CONTACT, PIN (NEUTRAL) .....	1
4	PAFZZ	81349	M39029/48-320	..CONTACT, PIN (A, B, AND C) .....	3
5	PAFOZ	81349	MS90564-4C	..COVER, ELECTRICAL CONNECTOR .....	1
6	PAFZZ	81349	MS90561-2	..GRIP, CABLE, STRAIN RELIEF .....	1
7	PAFZZ	81349	MS23747-2	..GLAND, CABLE SEALING .....	1
8	PAFZZ	77820	10-473421-1	..SCREW, RECESSED, HEX HEAD.....	4
9	PAFZZ	96906	MS35338-137	..LOCKWASHER, 60-AMP CONNECTOR.....	4
10	PAFFF	81349	MS90557-C32412S	..CONNECTOR, ELECTRICAL, RECEPTACLE	1
11	PAFZZ	81349	M39029/49-331	..CONTACT, SOCKET (A, B, C AND NEUTRAL)	4
12	PAFZZ	81349	M39029/49-329	..CONTACT, SOCKET (GROUND) .....	1
13	PAOZZ	81349	MS90563-7C	..COVER, ELECTRICAL CONNECTOR .....	1
14	PAFZZ	81349	MS90561-2	..GRIP, CABLE, STAIN RELIEF .....	1
15	PAFZZ	81349	MS23747-2	..GLAND, CABLE SEALING .....	1
16	PAFZZ	77820	10-473421-1	..SCREW, RECESSED, HEX HEAD .....	4
17	PAFZZ	96906	MS35338-137	..LOCKWASHER, 60-AMP CONNECTOR.....	4
18	PAFZZ	81349	M23053/5-112-4	..SLEEVING, INSULATION.....	2
19	PAFZZ	81349	CO-04HDF (4/6-4/12R) 1100	CABLE.....	1
END OF FIGURE					

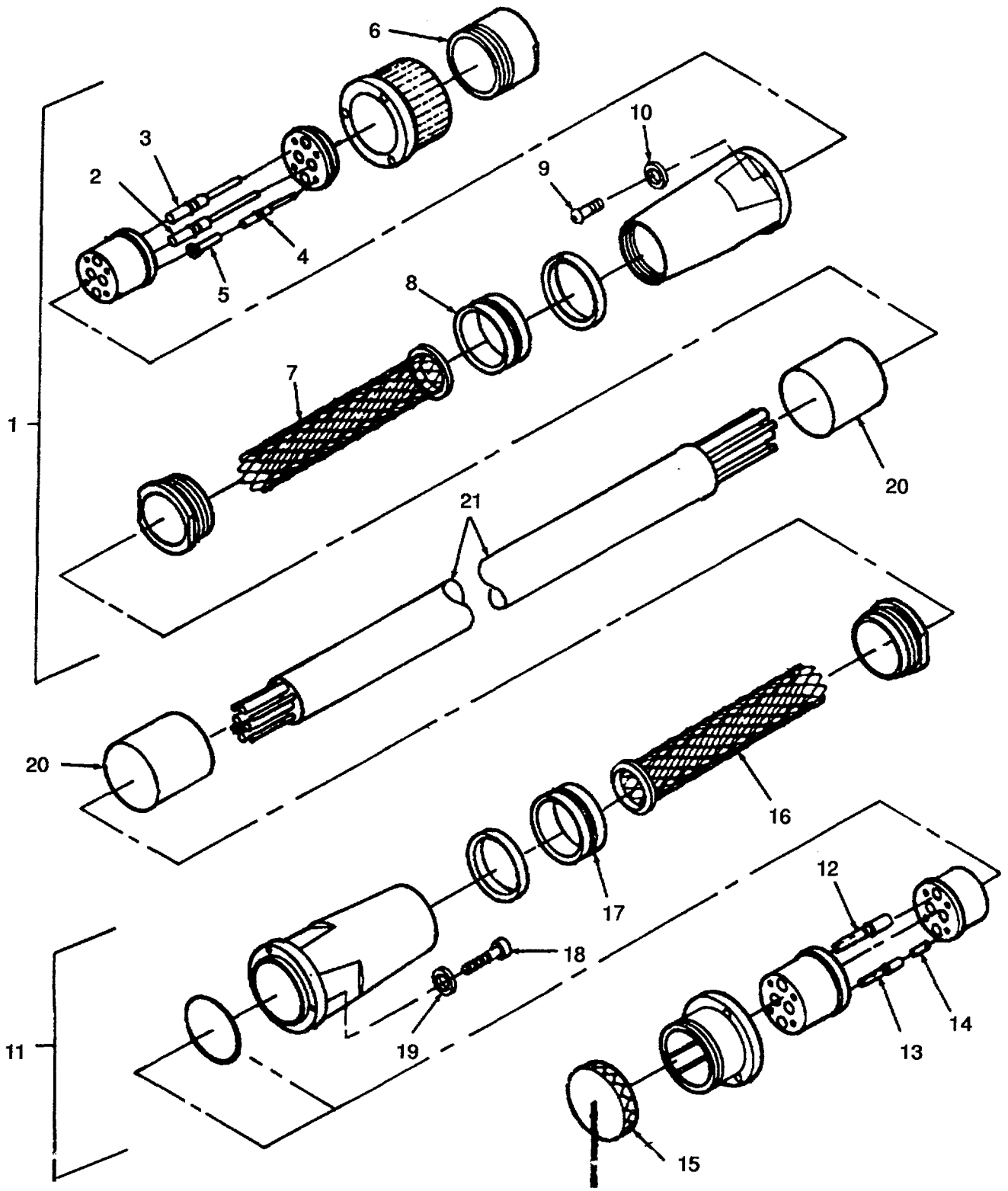

Figure F-12. 100-Amp Power Cable Assembly.



SECTION II.

(1) ITEM NO	(2) SMR CODE	(3) CAGEC	(4) PART NUMBER	(5) DESCRIPTION AND USABLE ON CODES (UOC)	(6) QTY
				GROUP 12 CABLE ASSEMBLIES	
				FIG F-12 100-AMP POWER CABLE ASSY	
	AF FFF	81349	M29184/2	CABLE ASSY, POWER, 100-AMP .....	4
1	PA FFF	81349	MS90556- C44412P	(USED WITH J3 THRU J6) .CONNECTOR, ELECTRICAL, PLUG .....	1
2	PA FZZ	81349	M39029/48-324	..CONTACT, PIN (NEUTRAL) .....	1
3	PA FZZ	81349	M39029/48-323	..CONTACT, PIN (A, B, AND C) .....	3
4	PA FZZ	81349	M39029/48-319	..CONTACT, PIN (GROUND) .....	4
5	PA FZZ	96906	MS33484-9L	..BUSHING .....	4
6	PA OZZ	81349	MS90564-7C	..COVER, ELECTRICAL CONNECTOR .....	1
7	PA FZZ	81349	MS90561-15	..GRIP, CABLE, STRAIN RELIEF .....	1
8	PA FZZ	81349	MS23747-15	..GLAND, CABLE SEALING .....	1
9	PA FZZ	77820	10-473421 -3	..SCREW, RECESSED, HEX HEAD .....	4
10	PA FZZ	96906	MS35338-139	..LOCKWASHER, 100-AMP CONNECTOR .....	4
11	PA FFF	81349	MS90557- C44412S	.CONNECTOR, ELECTRICAL, RECEPTACLE .....	1
12	PA FZZ	81349	M39029/49-333	.. CONNECTOR, ELECTRICAL, RECEPTACLE -.....	4
13	PA FZZ	81349	M39029/49-330	.. CONTACT, SOCKET (A, B, C AND NEUTRAL).....	4
14	PA FZZ	96906	MS33484-9L	..BUSHING .....	4
15	PA OZZ	81349	MS90563-7C	..COVER, ELECTRICAL CONNECTOR .....	1
16	PA FZZ	81349	MS90561-15	..GRIP, CABLE, STRAIN RELIEF .....	1
17	PA FZZ	81349	MS23747-15	..GLAND, CABLE SEALING .....	1
18	PA FZZ	77820	10-473421-3	..SCREW, RECESSED, HEX HEAD .....	4
19	PA FZZ	96906	MS35338-139	..LOCKWASHER, 100-AMP CONNECTOR .....	4
20	PA FZZ	81349	M23053/5-113-4	.SLEEVEING, INSULATION .....	2
21	PA FZZ	81349	C0-04HDF (4/2-4/8R) 1435	CABLE .....	1
				END OF FIGURE	

SECTION II.

(1) ITEM NO	(2) SMR CODE	(3) CAGEC	(4) PART NUMBER	(5) DESCRIPTION AND USABLE ON CODES (UOC)	(6) QTY
GROUP 13 BULK MATERIALS					
FIG. BULK					
1	PAFZZ	81349	M5086/2-2-0	WIRE, ELECTRICAL, 2 AWG, BLACK .....	V
2	PAFZZ	81349	M5086/2-6-0	WIRE, ELECTRICAL, 6 AWG, BLACK .....	V
3	PAFZZ	81349	M5086/2-6-2	WIRE, ELECTRICAL, 6 AWG, RED .....	V
4	PAFZZ	81349	M5086/2-6-6	WIRE, ELECTRICAL, 6 AWG, BLUE .....	V
5	PAFZZ	81349	M5086/2-6-9	WIRE, ELECTRICAL, 6 AWG, WHITE.....	V
6	PAFZZ	81349	M5086/2-6-5	WIRE, ELECTRICAL, 6 AWG, GREEN .....	V
7	PAFZZ	81349	M5086/2-8-5	WIRE, ELECTRICAL, 8 AWG, GREEN .....	V
8	PAFZZ	81349	M5086/2-18-0	WIRE, ELECTRICAL, 18 AWG, BLACK .....	V
9	PAFZZ	81349	M5086/2-18-2	WIRE, ELECTRICAL, 18 AWG, RED.....	V
10	PAFZZ	81349	M5086/2-18-6	WIRE, ELECTRICAL, 18 AWG, BLUE.....	V
11	PAFZZ	81349	M5086/2-18-9	WIRE, ELECTRICAL, 18 AWG, WHITE .....	V
END OF FIGURE					

F40

**SECTION III. SPECIAL TOOLS LIST**

(Not Applicable)

**CROSS-REFERENCE INDEXES**  
**SECTION IV.**  
**NATIONAL STOCK NUMBER INDEX (CONTINUED)**

STOCK NUMBER	FIG.	ITEM	STOCK NUMBER	FIG.	ITEM
5999-00-0-4-0939	F-11	2	5320-00-234-8572	F-10	4
5999-00-014-0941	F-11	4	5320-00-242-1578	F-10	6
5999-00-014-0943	F-11	3	5320-00-242-1580	F-2	1
5999-00-014-0952	F-9	7	5320-00-242-1580	F-10	2
5999-00-014-0952	F-11	12	5310-00-250-9477	F-5	53
5305-00-021-3668	F-5	52	5920-00-280-4960	F-6	8
6210-00-045-8458	F-4	6	5920-00-288-4965		
6210-00-045-8458	F-4	7	6145-00-340-8686	BULK	8
5305-00-050-9230			5975-00-451-5001	F-8	18
5305-00-054-5649	F-10	31	5310-00-477-6768	F-10	20
5305-00-054-6652			5310-00-477-6768	F-10	36
5305-00-054-6667			5310-00-527-3634	F-10	35
5305-00-054-6670	F-2	10	5310-00-543-2740	F-3	2
5305-00-059-3658	F-3	12	5310-00-543-2740	F-5	55
5305-00-059-3660	F-4	19	5310-00-543-2740	F-6	2
5305-00-059-3660	F-4	21	5310-00-543-2740	F-9	11
5305-00-059-3660	F-5	14	5306-00-543-4405	F-5	68
5305-00-059-3660	F-5	25	5310-00-543-5933	F-5	62
5305-00-059-3660	F-5	28	5310-00-543-5933	F-5	66
5305-00-059-3661	F-5	8	5940-00-557-4339	F-10	38
5305-00-059-3661	F-5	11	6145-00-578-6594	BULK	6
5305-00-059-3661	F-5	60	6145-00-578-6602	BULK	11
5305-00-059-3661	F-5	65	5310-00-582-5677	F-4	11
5305-00-059-3661	F-6	1	5310-00-582-5677	F-5	49
5305-00-059-3662	F-5	23	5310-00-582-5677	F-5	54
5305-00-059-3664	F-5	30	5310-00-582-5677	F-6	10
5305-00-059-3665	F-5	31	5310-00-625-5756	F-5	71
5305-00-071-1314	F-5	45	5305-00-702-4523	F-5	21
5305-00-071-1314	F-5	48	5305-00-702-4523	F-5	33
5305-00-071-1317	F-9	10	5305-00-702-4523	F-5	35
5305-00-071-1318	F-6	1	5305-00-702-4523	F-6	9
5305-00-071-2087	F-6	5	5305-00-719-5037	F-5	9
5305-00-071-2088	F-4	15	5305-00-719-5037	F-5	12
5975-00-074-2072			5975-00-727-5153	F-7	4
5935-00-093-5199			5310-00-767-0445	F-5	69
5935-00-114-9740	F-9	4	5310-00-773-7618	F-10	22
6145-00-169-3952	BULK	10	5970-00-787-2310	F-8	13
5310-00-180-0277	F-10	21	6210-00-836-2564	F-4	5
5305-00-207-8253	F-5	43	5310-00-883-9384	F-5	61
5305-00-207-8253	F-10	34	5920-00-892-9311	F-6	7
5310-00-208-9255	F-3	13	5310-00-934-9765	F-5	63
6150-00-220-5587	F-1	2	6240-00-939-7859	F-4	7
6145-00-223-7763	BULK	1	5310-00-982-4999	F-10	32
6145-00-226-2071	BULK	2	5310-00-982-6814	F-2	9
5320-00-234-8572	F-2	3	6145-00-989-7768	BULK	9

## CROSS-REFERENCE INDEXES

## NATIONAL STOCK NUMBER INDEX (CONTINUED)

STOCK NUMBER	FIG.	ITEM	STOCK NUMBER	FIG.	ITEM
9905-01-B79-1145	F-2	8	5975-01-288-6805	F-4	1
5975-01-034-5871			7690-01-289-2819		
5999-01-091-3187	F-9	5	7690-01-289-4774	F-10	33
5999-01-091-3187	F-11	11	5940-01-290-2812		
5999-01-130-1897	F-9	14	5940-01-290-2812	F-6	3
5999-01-130-1897	F-12	2	6150-01-290-5194	F-5	38
5999-01-130-1899	F-12	3	6150-01-290-6394	F-5	13
5999-01-131-5588	F-9	16	5320-01-292-1453	F-5	19
6150-01-220-5587	F-12		5320-01-292-1453	F-5	41
6150-01-220-5588	F-12		5925-01-292-8228	F-4	14
6150-01-220-5588	F-11		5340-01-294-0029	F-10	10
6110-01-248-6671	F-1		5340-01-309-6548		
6150-01-258-1202	F-1	1	5330-01-314-0008	F-5	13
5306-01-287-8627	F-5	2	5340-01-322-0882		
5310-01-288-0000	F-4	17	5340-01-331-0118	F-10	5
5310-01-288-0000	F-5	3	5306-01-379-1150	F-10	23
5310-01-288-0903	F-5	4	5999-01-713-4552	F-12	2
5975-01-288-6804	F-3	11			

## CROSS REFERENCE INDEX

## PART NUMBER INDEX (CONTINUED)

CAGEC	PART NUMBER	STOCK NUMBER	FIG.	ITEM
46384	CLS-0423-3		F-6	12
46384	CLS-0423-3		F-9	12
46384	CLSS-032-3		F-9	3
81349	CO44HDF (4/2-4/9R) 1465		F-12	20
81349	CO-04-HDF (4/6-4/192R) 1090		F-11	18
74829	C11		F-3	3
74829	D-20388-10		F-6	6
81349	FHN26G1	5920-00-892-9311	F-6	7
81349	F02A250V2A	5920-00-280-4960	F-6	8
89946	KD3400	5925-01 -292-8228	F-6	14
81349	LC14GN3	6210-00-045-8458	F-6	6
81349	LH76/3	6210-00-836-2564	F-6	5
74829	LO-0		F-10	37
81349	MIL-1-631 D		F-4	8
96906	MS15795-810	5310-00-582-5677	F-4	11
96906	MS15795-810	5310-00-582-5677	F-5	49
96906	MS15795-810	5310-00-582-5677	F-5	54
96906	MS15795-810	5310-00-582-5677	F-6	10
96906	MS15795-812	5310-00-625-5756	F-5	71
96906	MS15795-814	5310-00-773-7618	F-10	22
96906	MS15795-842	5310-00-883-9384	F-5	61
96906	MS18012-5		F-10	7
96906	MS20470A5-5	5320-00-234-8572	F-2	3
96906	MS20470A5-5	5320-00-234-8572	F-10	4
96906	MS20470A6-6	5320-00-242-1580	F-2	1
96906	MS20470A6-6	5320-00-242-1580	F-10	2
96906	MS20470A6-8	5320-00-242-1578	F-10	6
96906	MS21044C04	5310-00-982-4999	F-10	32
96906	MS21044C08	5310-00-982-6814	F-2	9
96906	MS21044C3	5310-00-208-9255	F-3	13
96906	MS23747-15		F-12	8
96906	MS23747-15		F-12	17
96906	MS23747-2		F-11	7
96906	MS23747-2		F-11	15
96906	MS25036-126	5940-00-557-4339	F-10	38
96906	MS3348-1-2L		F-9	15
96906	MS3348-4-6L		F-9	6
96906	MS3348-6-8L		F-9	17
96906	MS3348-6-9L		F-12	5
96906	MS3348-6-9L		F-12	14
96906	MS3367-1 -9		F-8	17
96906	MS3367-3-9	5975-00-451 -5001	F-8	18
96906	MS3367-4-9	5975-01 -727-5153	F-7	4
96906	MS35307-306	5305-00-702-4523	F-5	21
96906	MS35307-306	5305-00-702-4523	F-5	33
96906	MS35307-306	5305-00-702-4523	F-5	35

## CROSS REFERENCE INDEX

## PART NUMBER INDEX (CONTINUED)

CAGEC	PART NUMBER	STOCK NUMBER	FIG.	ITEM
96906	MS35307-306	5305-00-702-4523	F-6	9
96906	MS35307-308	5305-00-207-8253	F-5	43
96906	MS35307-308	5305-00-207-8253	F-10	34
96906	MS35307-310	5305-00-021-3668	F-5	52
96906	MS35307-334	5306-00-543-4405	F-5	68
96906	MS35333-73	5310-00-543-5933	F-5	62
96906	MS35333-73	5310-00-543-5933	F-5	66
96906	MS35333-74	5310-00-543-2740	F-3	2
96906	MS35333-74	5310-00-543-2740	F-5	55
96906	MS35333-74	5310-00-543-2740	F-6	2
96906	MS35333-74	5310-00-543-2740	F-9	11
96906	MS35333-75		F-5	70
96906	MS35333-76	5310-00-180-0277	F-10	21
96906	MS35335-61	5310-00-527-3634	F-10	35
96906	MS35335-75	5310-00-942-5109		
96906	MS35338-137		F-11	9
96906	MS35338-137		F-11	17
96906	MS35338-139		F-12	10
96906	MS35338-139		F-12	19
96906	MS35649-2254		F-5	53
96906	MS35649-2254			
96906	MS35649-2384		F-10	36
96906	MS35649-2384		F-10	20
96906	MS35650-304		F-5	63
96906	MS51957-15		F-10	31
96906	MS51957-28		F-4	13
96906	MS51957-42		F-7	1
96906	MS51957-45	5305-00-054-6670	F-2	10
96906	MS51957-64	5305-00-050-9230		
96906	MS51957-77		F-3	1
96906	MS51957-78	5305-00-071-1314	F-5	45
96906	MS51957-78	5305-00-071 -1314	F-5	48
96906	MS51957-82	5305-00-071 -1317	F-9	10
96906	MS51957-83	5305-00-071 -1318	F-6	1
96906	MS51957-83		F-6	
96906	MS51957-84	5305-00-071 -2087	F-4	5
96906	MS51957-85	5305-00-071 -2088	F-4	15
96906	MS51957-86		F-3	10
96906	MS51958-62	5305-00-059-3658	F-4	12
96906	MS51958-64	5305-00-059-3660	F-4	19
96906	MS51958-64	5305-00-059-3660	F-5	21
96906	MS51958-64	5305-00-059-3660	F-5	14
96906	MS51958-64	5305-00-059-3660	F-5	25
96906	MS51958-64	5305-00-059-3660	F-5	28
96906	MS51958-65	5305-00-059-3661	F-5	8
96906	MS51958-65	5305-00-059-3661	F-5	11

## CROSS REFERENCE INDEX

## PART NUMBER INDEX (CONTINUED)

CAGEC	PART NUMBER	STOCK NUMBER	FIG.	ITEM
96906	MS51958-65	5305-00-059-3661	F-5	60
96906	MS51958-65	5305-00-059-3661	F-5	65
96906	MS51958-65	5305-00-059-3661	F-5	1
96906	MS51958-66	5305-00-059-3662	F-5	23
96906	MS51958-68	5305-00-059-3664	F-5	30
96906	MS51958-69	5305-00-059-3665	F-5	31
96906	MS51959-78	5305-00-719-5037	F-5	9
96906	MS51959-78	5305-00-719-5037	F-5	12
96906	MS51971 -2	5305-00-767-0445	F-5	69
96906	MS53307-308		F-5	37
96906	MS90555C32412S	5935-00-114-9740	F-9	4
96906	MS90555C44412S		F-9	13
96906	MS90556C32412P		F-11	1
96906	MS90556C44412P		F-12	1
96906	MS90557C32412S		F-11	10
96906	MS90557C44412S		F-12	11
96906	MS90561-15		F-12	7
96906	MS90561-15		F-12	16
96906	MS90561 -2		F-11	6
96906	MS90561-2		F-11	14
96906	MS90563-3C		F-9	8
96906	MS90563-7C		F-9	18
96906	MS90563-7C		F-11	13
96906	MS90564C		F-11	5
96906	MS90564-7C		F-12	6
81349	M23053/5-101-0	5970-00-787-2310	F-8	13
81349	M23053/5-112-4		F-11	18
81349	M23053/5-113-4		F-12	20
98749	M29183/19	6110-01-248-6671	F-1	
81349	M29184/1-02	6150-01 -258-1202	F-1	1
81349	M29184/2	6150-01 -220-5587	F-1	3
81349	M29184/2	6150-01 -220-5587	F-12	
81349	M29184/3-02	6150-01 -220-5588	F-1	2
81349	M29184/3-02	6150-01-220-5588	F-11	
81349	M39029/48-318	5999-00-014-0939	F-11	2
81349	M39029/48-319		F-12	4
81349	M39029/48-320	5999-00-014-0941	F-11	4
81349	M39029/48-321	5999-00-014-0943	F-11	3
81349	M39029/48-323	5999-01-130-1899	F-12	3
81349	M39029/48-324	5999-01-113-4552	F-12	2
81349	M39029/49-329	5999-00-014-0952	F-9	7
81349	M39029/49-329	5999-00-014-0952	F-11	12
81349	M39029/49-330	5999-01-131-5588	F-9	16
81349	M39029/49-331	5999-01 -091 -3187	F-9	5
81349	M39029/49-331	5999-01-091-3187	F-11	11
81349	M39029/49-333	5999-01 -130-1897	F-9	14



## CROSS REFERENCE INDEX

## PART NUMBER INDEX (CONTINUED)

CAGEC	PART NUMBER	STOCK NUMBER	FIG.	ITEM
81349	M39029/49-333	5999-01 -130-1897	F-12	12
81349	M5086/2-18-0	6145-01 -340-8686	BULK	8
81349	M5086/2-18-2	6145-00-989-7768	BULK	9
81349	M5086/2-18-6	6145-00-169-3952	BULK	10
81349	M5086/2-18-19	6145-00-578-6602	BULK	11
81349	M5086/2-2-0	6145-01 -223-7763	BULK	1
81349	M5086/2-6-0	6145-01-226-2071	BULK	2
81349	M5086/2-6-2		BULK	3
81349	M5086/2-6-5		BULK	6
81349	M5086/2-6-6		BULK	4
81349	M5086/2-8-9	6145-00-578-6594	BULK	5
81349	M5086/2-8-5		BULK	7
03007	NHML8022LM		F-10	11
03007	NHAL8022ORF(HS)		F-10	28
74829	PDB-22-350-1		F-6	4
74829	PDB-22-350-3	5940-01-290-2812	F-6	3
89946	QBHW3060H		F4	18
89946	QBHW3100H		F4	20
14726	SS22499F		F-8	16
8Z640	TA50220		F-5	1
0E8J0	1000-U45/U142/113/23/24/991		F-10	25
0E8J0	1010-1		F-5	56
0E8J0	1010-2		F-4	4
77820	10-3667-48		F-9	19
77820	10-473421-1		F-11	8
77820	10-473421 -3		F-12	9
77820	10-473421 -3		F-12	18
58854	120 MB	6240-00-939-7859	F-4	7
82240	2-25-0006-02	5340-01-331-0118	F-10	5
82240	2-25-0009-02		F-2	2
89946	22D9175H04	5310-01 -288-0000	F-4	17
89946	22D9175H04	5310-01 -288-0000	F-5	3
51511	24190		F-2	11
28500	2420		F-6	13
1Y964	250MCM BLACK LW V7-700		F-8	14
28520	2783		F-6	14
89946	3456B03H01		F-5	24
89946	3456B04H01		F-5	27
89946	3456B85H01 -4		F-5	29
1Y964	4/0 BLACK		F-8	15
89946	5078A26H01		F-5	39
89946	5078A27H01	6150-01 -290-5194	F-5	38
89946	5078A56H01		F-5	42
89946	5078A57H01		F-5	7
89946	5078A58H01		F-5	10
89946	5078A59H01	6150-01 -290-6394	F-5	13

## CROSS REFERENCE INDEX

## PART NUMBER INDEX (CONTINUED)

CAGEC	PART NUMBER	STOCK NUMBER	FIG.	ITEM
	5079A04H01		F-5	5
	5079A15H01		F-5	40
	5079A20H01		F-5	6
	5079A21H01		F-5	16
	5156C01H03		F-5	22
	5156C03H01		F-5	26
8Z640	5156C05G03		F-5	59
	5156C05H01		F-5	47
89946	5156C07H02		F-5	20
89946	5158C03G02		F-5	64
89946	6550C57H01		F-5	50
89946	6552C10H01		F-5	34
89946	6552C19H01		F-5	32
89946	6552C30H01		F-5	51
89946	6563C09H17		F-5	44
89946	6573C08G07		F-5	36
89946	70041GA095	5306-01-287-8627	F-4	16
89946	70041GA095	5306-01-287-8627	F-5	2
89946	748A050H18	5310-01 -288-0903	F-5	4
89946	7499A46H01	5320-01 -292-1453	F-5	19
89946	7499A46H01	5320-01 -292-1453	F-5	41
98749	7503A77G01		F-4	9
83797	76130P/S-2		F-10	26
83797	76130P/S-4		F-2	5
83797	76130P/S-5		F-2	6
98749	8642388		F-2	12
98749	8642395		F-5	46
98749	8642402-1		F-8	1
98749	8642402-14		F-8	8
98749	8642402-15		F-8	9
98749	8642402-16		F-8	10
98749	8642402-17		F-8	11
98749	8642402-3		F-8	2
98749	8642402-4		F-8	3
98749	8642402-5		F-8	4
98749	8642402-6		F-8	5
98749	8642402-7		F-8	6
98749	8642402-8		F-8	7
98749	8642404		F-7	3
98749	8642527		F-10	12
98749	8642530			
98749	8642531		F-2	7
98749	8642533-1		F-10	9
98749	8642533-2	5340-01 -294-0029	F-10	10
98749	8642534		F-10	24
98749	8642535		F-5	67

## CROSS REFERENCE INDEX

## PART NUMBER INDEX (CONTINUED)

CAGEC	PART NUMBER	STOCK NUMBER	FIG.	ITEM
98749	8642536		F-10	8
98749	8642538		F-10	29
98749	8642539		F-6	11
98749	8642542-1		F-10	13
98749	8642542-2		F-10	14
98749	8642542-3		F-10	15
98749	8642542-4		F-10	16
98749	8642542-5		F-10	17
98749	8642542-6		F-10	18
98749	8642542-7		F-10	19
98749	8642544		F-10	30
98749	8642552	5306-01 -B79-1150	F-10	23
98749	8642556		F-4	12
98749	8642559		F-6	
98749	8642624	7690-01-289-4774	F-10	33
98749	8642625	9905-01-B79-1145	F-2	8
98749	8642626-1		F-10	39
98749	8642626-10		F-3	9
98749	8642626-10		F-3	10
98749	8642626-11	5975-01-288-6804	F-3	11
98749	8642626-12		F-3	4
98749	8642626-13		F4	3
98749	8642626-14		F-3	5
98749	8642626-15		F-3	6
98749	8642626-16		F-10	27
98749	8642626-17		F-10	47
98749	8642626-2		F-10	46
98749	8642626-3		F-10	41
98749	8642626-4		F-10	42
98749	8642626-5		F-10	43
98749	8642626-6		F-10	4
98749	8642626-7		F-3	8
98749	8642626-8		F-10	40
98749	8642626-9		F-3	7
98749	8642628		F-3	
98749	8642629		F-10	1
98749	8642649		F-5	
98749	8642654	5975-01-288-6805	F4	1
03007	86786-0788		F-2	4
03007	86787-0788		F-10	7
27190	9404498		F-7	2

## CROSS REFERENCE INDEX

## FIGURE AND ITEM NUMBER INDEX

FIG.	ITEM	STOCK NUMBER	CAGEC	PART NUMBER
F-1		6110-01-248-6671	98749	M29183/19
F-1	1	6150-01-258-1202	81349	M29184/1 -02
F-1	2	6150-01-220-5588	81349	M29184/3-02
F-1	3	6150-01-220-5587	81349	M29184/2
F-2			98749	8642530
F-2	1	5320-00-242-1580	96906	MS20470A6-6
F-2	2		82240	2-25-0009-02
F-2	3	5320-00-234-8572	96906	MS20470A5-5
F-2	4		03007	86786-0788
F-2	5		83797	76130P/S-4
F-2	6		83797	76130P/S-5
F-2	7		98749	8642531
F-2	8	9905-01-B79-1145	98749	8642625
F-2	9	5310-00-982-6814	96906	MS21044C08
F-2	10	5305-00-054-6670	96906	MS51957-45
F-2	11		51511	24190
F-2	12		98749	8642388
F-3			98749	8642628
F-3	1		96906	MS51957-77
F-3	2	5310-00-543-2740	96906	MS35333-74
F-3	3		74829	C11
F-3	4		98749	8642626-12
F-3	5		98749	8642626-14
F-3	6		98749	8642626-15
F-3	7		98749	8642626-9
F-3	8		98749	8642626-7
F-3	9		98749	8642626-10
F-3	10		98749	8642626-11
F-3	11	5975-01-288-6804	98749	8642650
F-3	12	5305-00-593-3658	96906	MS51958-62
F-3	13	5310-00-208-9255	96906	MS21044C3
F-4	1	5975-01-288-9255	98749	8642654
F-4	2	5305-00-050-9230	96906	MS51957-64
F-4	3		98749	8642626-13
F-4	4		0E8J0	1010-2
F-4	5	6210-00-836-2564	81349	LH7613
F-4	6	6210-00-045-8458	81349	LC14GN3
F-4	7	6240-00-939-7859	92966	120MB
F-4	8		96906	MIL-I-631 D
F-4	9		98749	7503A77G01
F-4	10		96906	MS51957-86
F-4	11	5310-00-582-5677	96906	MS15795-810
F-4	12		98749	8642556
F-4	13	5305-00-054-6652	96906	MS51957-28
F-4	14	5925-01 -292-8228	89946	KD3400
F-4	15	5305-00-071 -2088	96906	MS51957-85

## CROSS REFERENCE INDEX

## FIGURE AND ITEM NUMBER INDEX

FIG.	ITEM	STOCK NUMBER	CAGEC	PART NUMBER
F-4	16	5306-01 -287-8627	89946	70041 GA095
F-4	17	5310-01 -288-0000	89946	22D9175H04
F-4	18		89946	QBHW3060H
F-4	19	5305-00-059-3661	96906	MS51958-64
F-4	20		89946	QBHW3100H
F-4	21	5305-00-059-3660	96906	MS51958-64
F-5			98749	8642649
F-5	1		82640	TA50220
F-5	2	5306-01-287-8627	89946	70041GA095
F-5	3	5310-01-288-0000	89946	22D9175H04
F-5	4	5310-01-288-0903	89946	748A050H18
F-5	5		89946	5079A04H01
F-5	6		89946	5079A20H01
F-5	7		89946	5078A57H01
F-5	8	5305-00-059-3661	96906	MS51958-65
F-5	9	5305-00-071-5037	96906	MS51959-78
F-5	10		89946	5078A58H01
F-5	11	5305-00-059-3661	96906	MS51958-65
F-5	12	5305-00-719-5037	96906	MS51959-78
F-5	13	6150-01-290-6394	89946	5078A59H01
F-5	14	5305-00-059-3661	96906	MS51958-65
F-5	15	5305-00-719-5037	96906	MS51959-78
F-5	16		89946	5079A21H01
F-5	17	5320-01-292-1453	89946	7499A46H01
F-5	18		89946	5079A20H01
F-5	19	5320-01-292-1453	89946	7499A46H01
F-5	20		89946	5156C07H02
F-5	21	5305-00-702-4523	96906	MS35307-306
F-5	22		89946	5156C01H01
F-5	23	5305-00-059-3661	96906	MS51958-66
F-5	24		89946	3456B03H01
F-5	25	5305-00-059-3660	96906	MS51958-64
F-5	26		89946	5156C03H01
F-5	27		89946	3456B04H01
F-5	28	5305-00-059-3660	96906	MS51958-64
F-5	29		89946	3456B85H01-4
F-5	30	5305-00-059-3664	96906	MS51958-68
F-5	31	5305-00-059-3665	96906	MS51958-69
F-5	32		89946	6552C19H01
F-5	33	5305-00-702-4523	96906	MS35307-306
F-5	34		89946	6552C10H01
F-5	35	5305-00-702-4523	96906	MS35307-306
F-5	36		89946	6573C08G07
F-5	37	5305-00-207-8253	96906	MS53307-308
F-5	38		89946	5078A27H01
F-5	39		89946	5078A26H01

## CROSS REFERENCE INDEX

## FIGURE AND ITEM NUMBER INDEX

FIG.	ITEM	STOCK NUMBER	CAGEC	PART NUMBER
F-5	40		89946	5079A15H01
F-5	41	5320-01-292-1453	89946	7499A46H01
F-5	42		89946	5078A56H01
F-5	43		96906	M535307-308
F-5	44		89946	6563C09H17
F-5	45	5305-00-719-5037	96906	MS51957-78
F-5	46		98749	8642395
F-5	47		89946	5156C05H01
F-5	48	5305-00-071-1314	96906	MS51957-78
F-5	49	5310-00-582-5677	96906	MS15795-810
F-5	50		89946	6550C57H01
F-5	51		89946	6552C30H01
F-5	52	5305-00-021-3668	96906	MS35307-310
F-5	53	5310-00-250-9477	96906	MS35649-2254
F-5	54	5310-00-582-5677	96906	MS15795-810
F-5	55	5310-60-543-2740	96906	MS35333-74
F-5	56		0E8J0	1010-1
F-5	57		8Z640	5156C05G03
F-5	58	5305-00-702-4523	96906	MS35307-306
F-5	59		8Z640	5156C05G03
F-5	60	5305-00-059-3661	96906	MS51958-65
F-5	61	5310-00-883-9384	96906	MS15795-842
F-5	62	5310-00-543-5933	96906	MS35333-73
F-5	63	5310-00-934-9765	96906	MS35650-304
F-5	64		89946	5158C03G02
F-5	65	5305-00-059-3661	96906	MS51958-65
F-5	66	5310-00-543-5933	96906	MS35333-73
F-5	67		98749	8642535
F-5	68	5306-00-543-4405	96906	MS35307-334
F-5	69	5310-00-767-0445	96906	MS51971-2
F-5	70		96906	MS35333-75
F-5	71	5310-00-625-5756	96906	MS15795-812
F-6			98749	8642559
F-6	1	5305-00-071-1318	96906	MS51957-83
F-6	2	5310-00-543-2740	96906	MS35333-74
F-6	3	5940-01-290-2812	74829	PDB-22-350-3
F-6	4		74829	PDB-22-350-1
F-6	5	5305-00-071-2087	96906	MS51957-84
F-6	6		78429	D-20388-10
F-6	7	5920400-892-9311	81349	FHN26G1
F-6	8	5920-00-280-4960	81349	F02A250V2A
F-6	9	5305-00-702-4523	96906	MS35307-306
F-6	10	5310-00-582-5677	96906	MS15795-810
F-6	11		98749	8642539
F-6	12		46384	CLS-0420-3
F-6	13		28520	2420

CROSS REFERENCE INDEX

FIGURE AND ITEM NUMBER INDEX

FIG.	ITEM	STOCK NUMBER	CAGEC	PART NUMBER
F-6	14		28520	2783
F-7	1	5305-00-054-6667	96906	MS51957-42
F-7	2		27190	940-4498
F-7	3		98749	8642404
F-7	4	5975-00-727-5153	96906	MS3367-4-9
F-8	1		98749	8642402-1
F-8	2		98749	8642402-3
F-8	3		98749	8642402-4
F-8	4		98749	8642402-5
F-8	5		98749	8642402-6
F-8	6		98749	8642402-7
F-8	7		98749	8642402-8
F-8	8		98749	8642402-14
F-8	9		98749	8642402-15
F-8	10		98749	8642402-16
F-8	11		98749	8642402-17
F-8	12	5970-00-787-2310	81349	M23053/5-101 -0
F-8	13		1Y964	250MCM BLACK LWV-700
F-8	14		1Y964	4/0 BLACK
F-8	15		14726	SS22499F
F-8	16		96906	MS3367-1-9
F-8	17		96906	MS3367-3-9
		5975-00-451 -5001		
F-9	1	5305-00-059-3660	96906	MS51958-65
F-9	2	5310-00-543-5933	96906	MS35333-73
F-9	3		46384	CLSS-032-3
F-9	4	5935-00-114-9740	96906	MS90555C32412S
F-9	5	5999-01-091-3187	81349	M39029/49-331
F-9	6		96906	MS3348-46L
F-9	7	5999-00-014-0952	81349	M39029/49-329
F-9	8		96906	MS90563-3C
F-9	9		96906	MS52000-12
F-9	10	5305-00-071-1317	96906	MS51957-82
F-9	11	5310-00-543-2740	96906	MS35333-74
F-9	12		46384	CLS-0420-3
F-9	13		96906	MS90555C444125
F-9	14	5999-01-130-1897	81349	M39029/49-333
F-9	15		96906	MS3348-1-2L
F-9	16	5999-01-131-5588	81349	M39029/49-330
F-9	17		96906	MS3348-6-8L
F-9	18		96906	MS90563-7C
F-9	19		77820	10-3667-48
F-10	1		98749	8642629
F-10	2	5320-00-242-1580	96906	MS20470A6-6
F-10	3		03007	86787-0788
F-10	4	5320-00-234-8572	96906	MS20470A5-5

## CROSS REFERENCE INDEX

## FIGURE AND ITEM NUMBER INDEX

FIG.	ITEM	STOCK NUMBER	CAGEC	PART NUMBER
F-10	5	5340-01-331-0118	82240	2-25-0006-2
F-10	6	5320-00-242-1578	96906	MS20470A6-8
F-10	7		96906	MS18012-5
F-10	8		98749	8642536
F-10	9		98749	8642533-1
F-10	10	5340-01-294-0029	98749	8642533-2
F-10	11		03007	NHAL8022LM
F-10	12		98749	8642527
F-10	13		98749	8642542-1
F-10	14		98749	8642542-2
F-10	15		98749	8642542-3
F-10	16		98749	8642542-4
F-10	17		98749	8642542-5
F-10	18		98749	8642542-6
F-10	19		98749	8642542-7
F-10	20	5310-00-447-6768	96906	MS35649-2384
F-10	21		96906	MS35333-76
F-10	22	5310-00-773-7618	96906	MS15795-814
F-10	23	5306-01-B79-1150	98749	8642552
F-10	24		98749	8642534
F-10	25		0E8J0	1000-U45/U142- 113/23/24991
F-10	26		98749	76130P/S-2
F-10	27		98749	8642626-16
F-10	28		03007	NHAL80220RF (HS)
F-10	29		98749	8642538
F-10	30		98749	8642544
F-10	31	5305-00-054-5649	96906	MS51957-15
F-10	32	5310-00-982-4999	96906	MS21044C04
F-10	33	7690-01-289-4774	98749	8642624
F-10	34	5305-00-207-8253	96906	MS35307-308
F-10	35	5310-00-527-3634	96906	MS35335-61
F-10	36	5310-00-477-6768	96906	MS35649-2384
F-10	37		74829	LO-0
F-10	38	5940-00-557-4339	96906	MS25036-126
F-10	39		98749	8642626-1
F-10	40		98749	8642626-8
F-10	41		98749	8642626-3
F-10	42		98749	8642626-4
F-10	43		98749	8642626-5
F-10	44		98749	8642626-6
F-10	45		98749	8642626-7
F-10	46		98749	8642626-2
F-10	47		98749	8642626-17
F-11		6150-01-220-5588	81349	M29184/3-02
F-11	1		96906	MS90556C32412P
F-11	2	5999-00-014-0939	81349	M39029148-318



## CROSS REFERENCE INDEX

## FIGURE AND ITEM NUMBER INDEX

FIG.	ITEM	STOCK NUMBER	CAGEC	PART NUMBER
F-11	3	5999-00-014-0943	81349	M39029/48-321
F-11	4	5999-00-014-0941	81349	M39029/48-320
F-11	5		81349	MS90564-4C
F-11	6		81349	MS90561-2
F-11	7		81349	MS23747-2
F-11	8		77820	10-473421-1
F-11	9		96906	MS35338-137
F-11	10		81349	MS90557C32412S
F-11	11	5999-01-091-3187	81349	M39029/49-331
F-11	12	5999-00-014-0952	81349	M39029/49-329
F-11	13		81349	MS90563-7C
F-11	14		81349	MS90561-2
F-11	15		81349	MS23747-2
F-11	16		77820	10-473421-1
F-11	17		96906	MS35338-137
F-11	18		81349	M23053/5-112-4
F-11	19		81349	CO04HDF (4/6-41192R) 1090
F-12		6150-01-220-5587	81349	M29184/2
F-12	1		81349	MS90556C44412P
F-12	2	5999-01-113-4552	81349	M39029/48-324
F-12	3	5999-01-130-1899	81349	M39029/48-323
F-12	4		81349	M39029148-319
F-12	5		96906	MS3348-6-9L
F-12	6		81349	MS90564-7C
F-12	7		81349	MS90561 -15
F-12	8		81349	MS23747-15
F-12	9		77820	10-473421 -3
F-12	10		96906	MS35338-139
F-12	11		81349	MS90557C44412S
F-12	12	5999-01-130-1897	81349	MS9029149-333
F-12	13	5999-01-131-5588	81349	M39029/49-330
F-12	14		96906	MS3348-6-9L
F-12	15		81349	MS90563-7C
F-12	16		81349	MS90561 -15
F-12	17		81349	MS23747-15
F-12	18		77820	10-473421 -3
F-12	19		96906	MS35338-139
F-12	20		81349	M23053/5-113-4
F-12	21		81349	CO-04HDF (4/2-4/9R) 1465
BULK	1	6145-01-223-7763	81349	M5086/2-2-0
BULK	2	6145-01-226-2071	81349	M5086/2-6-0
BULK	3		81349	M5086/2-6-2
BULK	4		81349	M5086/2-6-6
BULK	5	6145-00-578-6594	81349	M5086/2-6-9
BULK	6	6145-01-203-6484	81349	M508612-6-5
BULK	7		81349	M508612-8-5

**CROSS REFERENCE INDEX**  
**FIGURE AND ITEM NUMBER INDEX**

FIG.	ITEM	STOCK NUMBER	CAGEC	PART NUMBER
BULK	8	6145-01-340-8686	81349	M5086/2-18-0
BULK	9		81349	M5086/2-18-3
BULK	10	6145-00-169-3952	81349	M5086/2-18-6
BULK	11	6145-00-578-6602	81349	M5086/2-18-9

**APPENDIX G  
ILLUSTRATED LIST OF MANUFACTURED ITEMS**

**SECTION I. INTRODUCTION**

**G.1 INTRODUCTION.**

a. This appendix includes complete instructions for making items authorized to be manufactured or fabricated at direct support maintenance level.

b. A part number index in alphanumeric order is provided for cross-referencing the part number of the item to be manufactured to the figure which covers fabrication criteria.

c. All bulk materials needed for manufacture of an item are listed by part number or specification number in tabular list on the illustration.

**G.2 GENERAL INFORMATION.**

a. Connector Crimping Tools. The cable and wall mount connectors have pin contacts (male) or socket contacts (female) that attach to the wires with a four-indent crimp. Table G-1 identifies which tools to use to crimp each type and size of connector contact. Table G-2 lists the various insert, removal, locator, and crimp tools you need to repair both cable and wall mount connectors.

*Table G-1. Crimp Tool Selection Chart*

**NOTE**

Cable-type connectors mount on cable ends. Wall-type connectors mount on the power distribution panel. Use needle-nose pliers to install pins or sockets which do not have a special installation tool listed.

Connector group/type	Pin/Socket size	Table G-2 Item No.			
		Remove tool	Installer tool	Locate tool	Crimp tool
100-amp, 8-wire connectors:					
Cable-type, large pin/socket	0	1	—	5c	5d
Cable-type, small pin/socket	6	3	—	5e	5f
Wall-type, large pin/socket	0	1	—	5c	5d
Wall-type, small pin/socket	6	3	—	5c	5f
60-, amp, 5 wire connectors:					
Cable-type, large pin/socket	4	2	4	5a	5b
Cable-type, small pin/socket	6	3	—	5e	5f
Wall-type, large pin/socket	4	2	4	5a	5b
Wall-type, small pin/socket	6	3	—	5e	5f

**G.2 GENERAL INFORMATION - CONTINUED.**

Table G-2. Crimp Tools

Item No.	Nomenclature	Size	Part Numbers
1	Removal Tool, Pin/Socket M81969/27-3	1	MS90562-3
2	Removal tool, pin/socket	4	TP201315-04
3	Removal tool, pin/socket M81969/274	6	MS90562-6
4	Installer tool, pin/socket	4	M81969/17-07
5	Crimp tool system, pneumatic 400-1-200-5KL	-	M25520/23-01
5a	Locator, pin/socket 4297-5	4	M22520/23-12
5b	Crimping die, pin/socket 414DA-4N	4	M25520/23-04
5c	Locator, pin/socket 4297-3	0	M22520/23-13
5d	Crimping die, pin/socket 414DA-1/on	0	M25520/23-05
5e	Crimping die, pin/socket 4297-6	6	M22520/23-10
5f	Crimping die, pin/socket 414DA-6N	6	M22520/23-03

b. Removal of Cable Insulation. When installing electrical connectors to cable ends, cut and remove cable jacket and insulation as follows:

- (1) 100-amp. 8-wire cables.



Do not cut insulation on individual wires when cutting cable jacket.

- (a) Carefully cut and remove 3-1/2 inches (89 mm) of outer cable jacket from end of cable.
- (b) Carefully cut and remove 7/8 inch (22 mm) of conductor insulation from each conductor.
- (c) Attach electrical connector to cable end.

- (2) 60-amp. 5-wire cables.



Do not cut insulation on individual wires when cutting cable jacket.

- (a) Carefully cut and remove 3-1/2 inches (89 mm) of outer cable jacket from end of cable.
- (b) Cut off 12 inch (13 mm) from phases A, B, C and neutral conductor (the four large conductors).
- (c) Carefully cut and remove 7/8 inch (22 mm) of conductor insulation from end of each conductor.
- (d) Attach electrical connector to cable end.

## SECTION II. MANUFACTURED ITEMS PART NUMBER INDEX

PART NO.	NSN	DESCRIPTION	FIG. NO
CO-04HDF (4/2-4/9R) 1465		Cable	G-2
CO-04HDF (4/6-4/192R) 1090		Cable	G-1
MS3348-6-9L		Bushing	G-2
MS90557C32412S		Connector, electrical receptacle	G-1
MS90557C44412S		Connector, electrical receptacle	G-2
MS90556C32412P		Connector, electrical straight plug	G-1
MS90556C44412P		Connector, electrical straight plug	G-2
M2305315-112-4		Sleeving, insulation, heat shrink	G-1
M23053/5-113-4		Sleeving, insulation, heat shrink	G-2
M39029/48-318		Contact, electrical pin	G-1
M39029/48-319		Contact, electrical pin	G-2
M39029/48-320		Contact, electrical pin	G-1
M39029/48-321		Contact, electrical pin	G-1
M39029/48-323		Contact, electrical pin	G-2
M39029/48-324		Contact, electrical pin	G-2
M39029/49-329		Contact, electrical socket	G-1
M39029/49-330		Contact, electrical socket	G-2
M39029149-331		Contact, electrical socket	G-1
M39029149-333		Contact, electrical socket	G-2

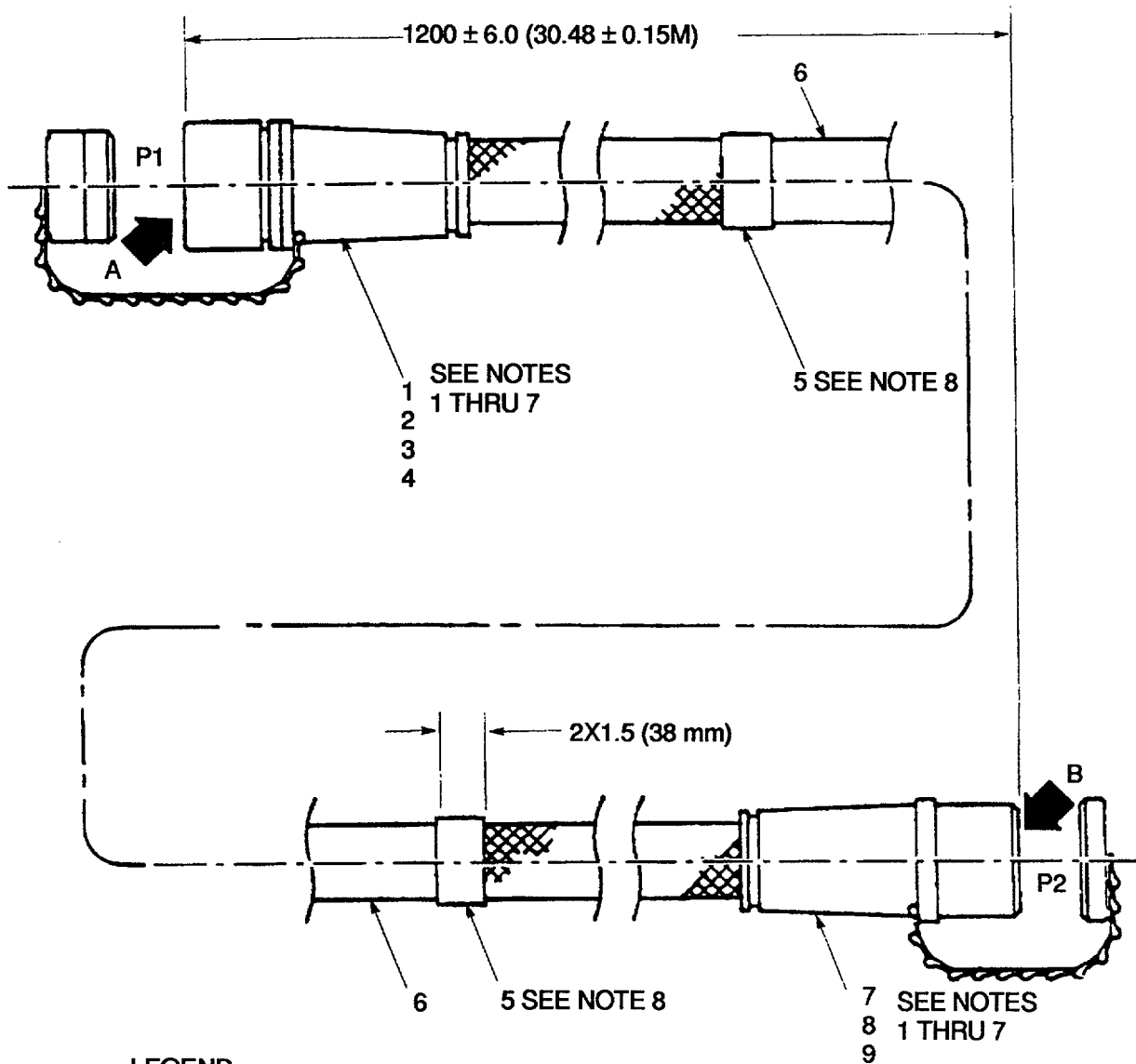

LEGEND

1. MS90556C32412P CONNECTOR, ELECTRICAL STRAIGHT PLUG (P1)
2. M39029/48-320 CONTACT, ELECTRICAL PIN (P1-A, B, C)
3. M39029/48-321 CONTACT, ELECTRICAL PIN (P1-N)
4. M39029/48-318 CONTACT, ELECTRICAL PIN (P1-G)
5. M23053/5-112-4 SLEEVING, INSULATION, HEAT SHRINK
6. CO-04HDF (4/6-4/192R) 1090 CABLE
7. MS90557C32412S CONNECTOR, ELECTRICAL RECEPTACLE (P2)
8. M39029/49-331 CONTACT, ELECTRICAL SOCKET (P2-A, B, C, N)
9. M39029/49-329 CONTACT, ELECTRICAL SOCKET (P2G)

Figure G1. 60-Amp, 100-Ft. (30.5m) Power Cable (Sheet 1 of 3).

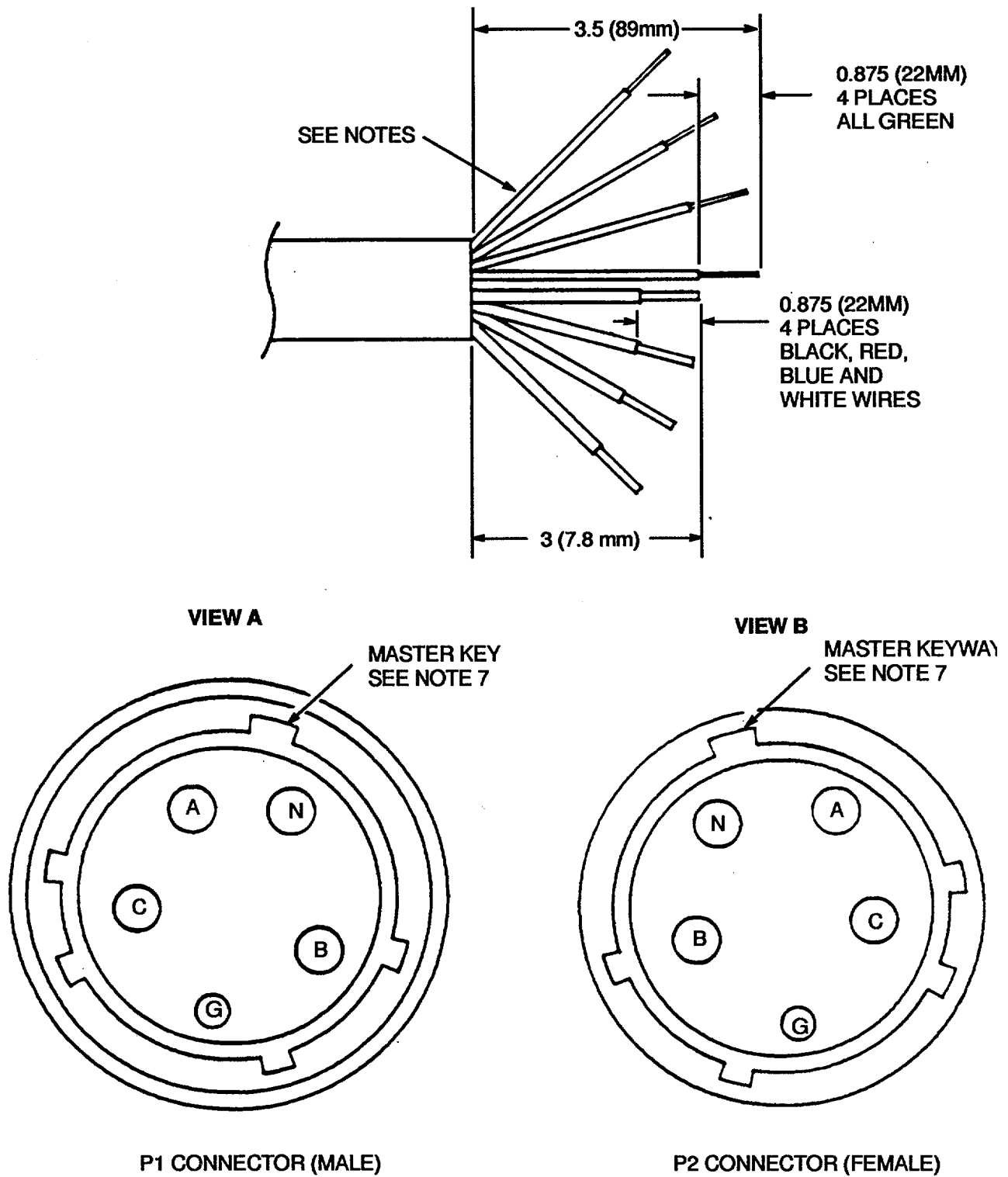

Figure G-1. 60-Amp, 100 Ft. (30.5m) Power Cable (Sheet 2 of 3).



Do not rely on the color of the wire insulation for phase color-coding. The insulation on the wires inside the cable jacket may vary, depending on the supplier. Wires will be marked with colored tape to designate the phases. Perform a continuity test to verify correct phase designation in accordance with the colored tape.

NOTES:

1. ALL DIMENSIONS ARE IN INCHES, WITH THE METRIC EQUIVALENT IN PARENTHESES.
2. CUT AND REMOVE CABLE AND WIRE INSULATION FROM CABLE ENDS AS INDICATED.
3. TWIST FOUR GROUND WIRES TOGETHER.
4. INSTALL P1 AND P2 CONNECTORS ON PROPER CABLE ENDS SO COLORS AND PINS/SOCKETS MATCH AS FOLLOWS:

COLOR	FROM	TO
BLACK	P1-A	P2-A
RED	P1-B	P2-B
BLUE OR ORANGE	P1-C	P2-C
WHITE	P1-N	P2-C
GREEN (OR BARE)	P1-G	P2-G
GREEN (OR BARE)	P1-G	P2-G
GREEN (OR BARE)	P1-G	P2-G
GREEN (OR BARE)	P1-G	P2-G

5. VERIFY ELECTRICAL CONTINUITY FOR EACH "FROM-TOP PATH WITH AN OHMMETER.
6. CRIMP PINS/SOCKETS TO CABLE WIRES. SEE TABLE G-1 AND G-2.
7. ASSEMBLE P1 AND P2 CONNECTORS SO KEYS/KEY-WAYS AND PIN/SOCKETS ALIGN AS INDICATED.
8. MARK SLEEVES IN ACCORDANCE WITH MIL-M-60903 AS FOLLOWS:

120/208 VAC  
 3-PHASE  
 60-AMP

Figure G-1. 60-Amp, 100 Ft. (30.5m) Power Cable (Sheet 3 of 3).



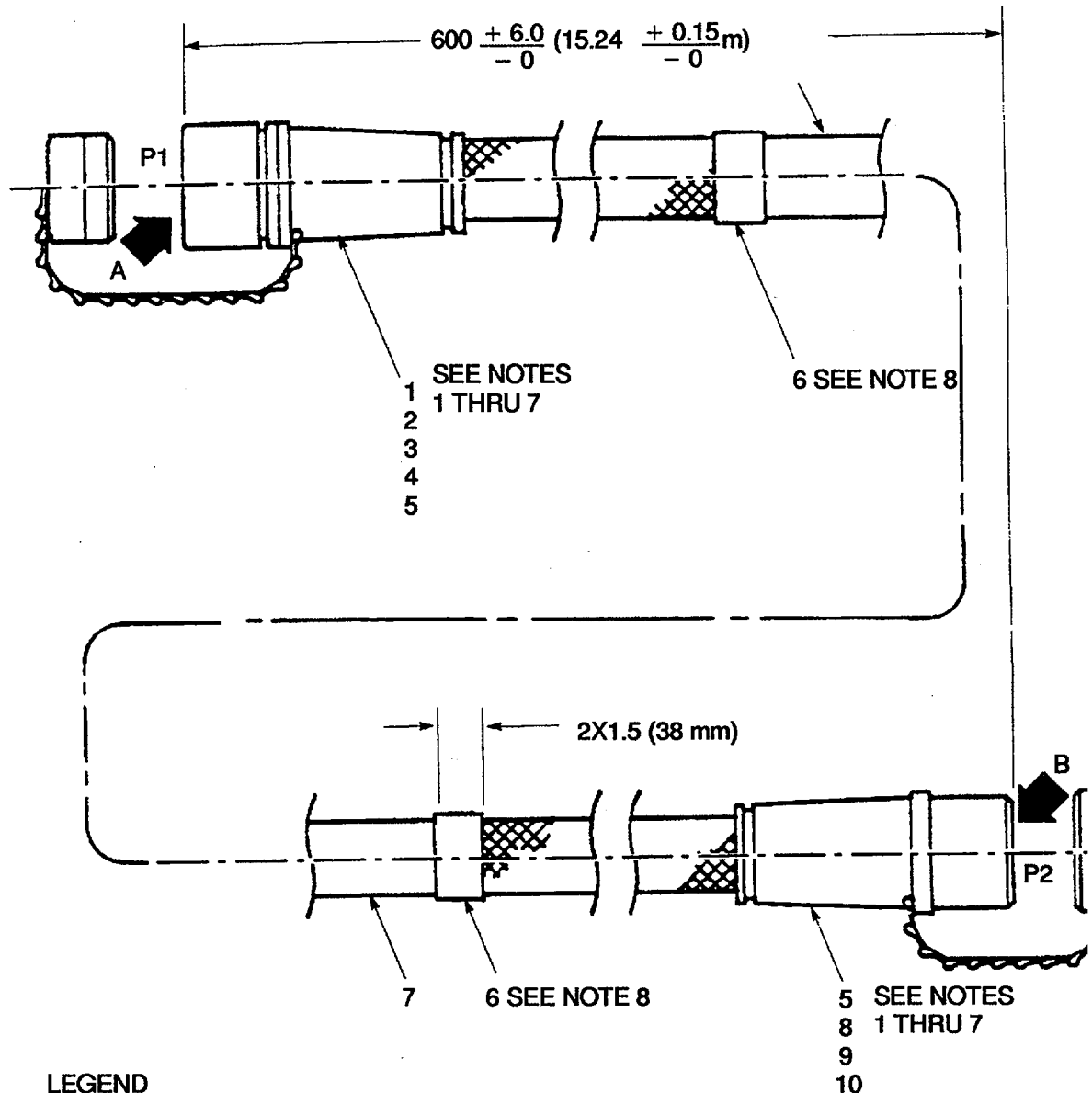

**LEGEND**

1. MS90556C44412P CONNECTOR, ELECTRICAL STRAIGHT PLUG (P1)
2. M39029/48-323 CONTACT, ELECTRICAL PIN (P1 -A, B, C)
3. M39029/48-324 CONTACT, ELECTRICAL PIN (P1 -N)
4. M39029/48-319 CONTACT, ELECTRICAL PIN (P1 -G1, G2, G3, G4)
5. MS3348-6-9L BUSHING ELECTRICAL CONTACTS (P1 AND P2-G , G3, G4)
6. M23053/5-113-4 SLEEVING, INSULATION, HEAT SHRINK
7. CO-04HDF (4/2-4/9R) 1465 CABLE
8. MS90557C44412S CONNECTOR, ELECTRICAL RECEPTACLE (P2)
9. M39029/49-333 CONTACT, ELECTRICAL SOCKET (P2-A, B, C, N)
10. M39029/49-330 CONTACT, ELECTRICAL SOCKET (P2-G1, G2, G3, G4)

Figure G-2. 100-Amp, 50-Ft. (15.2m) Power Cable (Sheet 1 of 3).

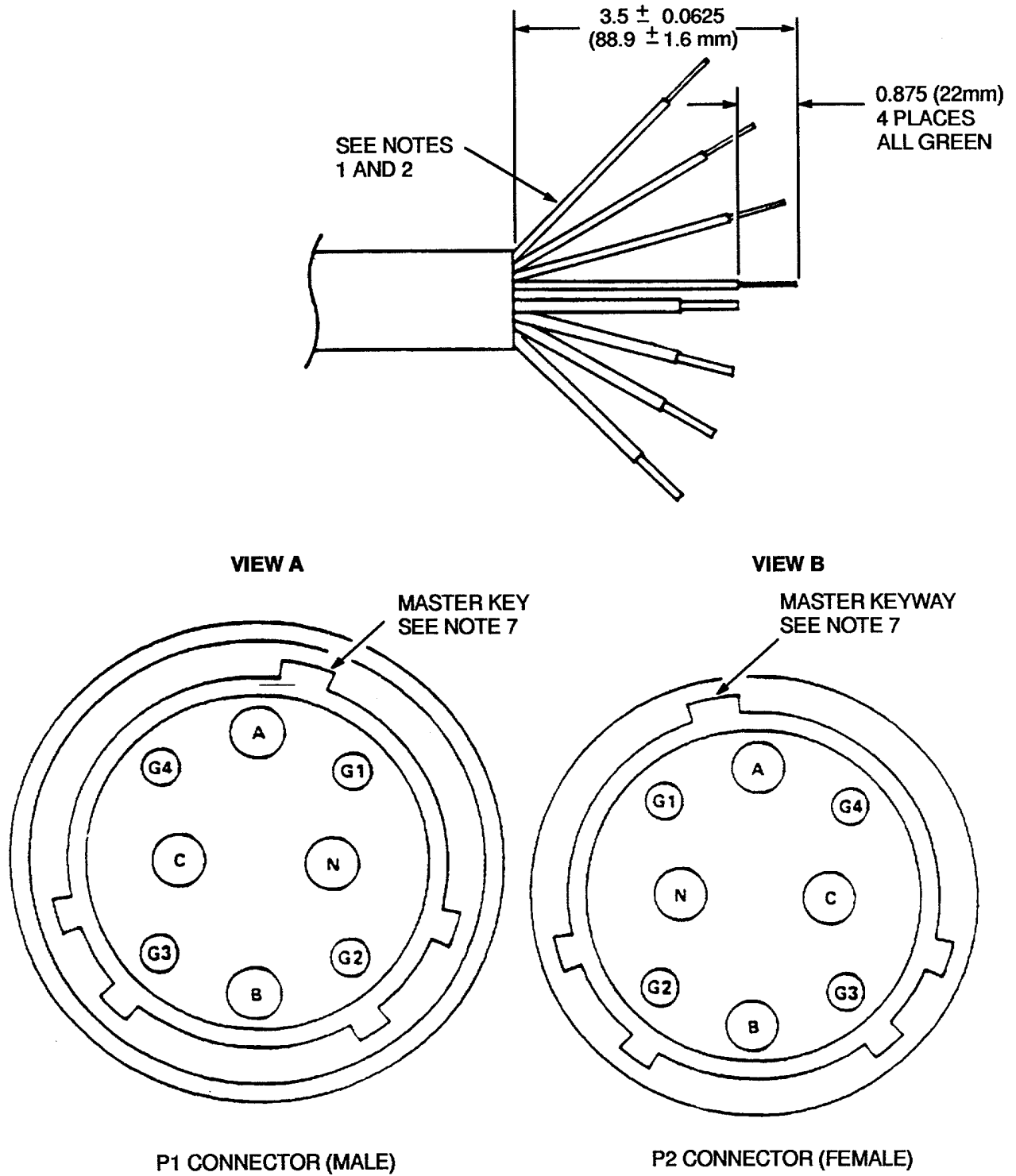

Figure G-2. 100-Amp, 50-Ft. (15.2m) Power Cable (Sheet 2 of 3).



Do not rely on the color of the wire insulation for phase color-coding. The insulation on the wires inside the cable jacket may vary, depending on the supplier. Wires will be marked with colored tape to designate the phases. Perform a continuity test to verify correct phase designation in accordance with the colored tape.

NOTES:

1. ALL DIMENSIONS ARE IN INCHES, WITH THE METRIC EQUIVALENT IN PARENTHESES.
2. CUT AND REMOVE CABLE AND WIRE INSULATION FROM CABLE ENDS AS INDICATED.
3. TWIST FOUR GROUND WIRES TOGETHER.
4. INSTALL P1 AND P2 CONNECTORS ON PROPER CABLE ENDS SO COLORS AND PINS/SOCKETS MATCH AS FOLLOWS:

COLOR	FROM	TO
BLACK	P1-A	P2-A
RED	P1-B	P2-B
BLUE OR ORANGE	P1-C	P2-C
WHITE	P1-N	P2-C
GREEN (OR BARE)	P1-G1	P2-G1
GREEN (OR BARE)	P1-G2	P2-G2
GREEN (OR BARE)	P1-G3	P2-G3
GREEN (OR BARE)	P1-G4	P2-G4

5. VERIFY ELECTRICAL CONTINUITY FOR EACH "FROM-TO" PATH WITH AN OHMMETER.
6. CRIMP PINS/SOCKETS TO CABLE WIRES. SEE TABLE G-1 AND G-2.
7. ASSEMBLE P1 AND P2 CONNECTORS SO KEYS(KEY-WAYS AND PIN/SOCKETS ALIGN AS INDICATED).
8. MARK SLEEVES IN ACCORDANCE WITH MIL-M-60903 AS FOLLOWS:

120/208 VAC  
3-PHASE  
60-AMP

*Figure G-2. 100-Amp, 50 Ft. (15.2m) Power Cable (Sheet 3 of 3).*

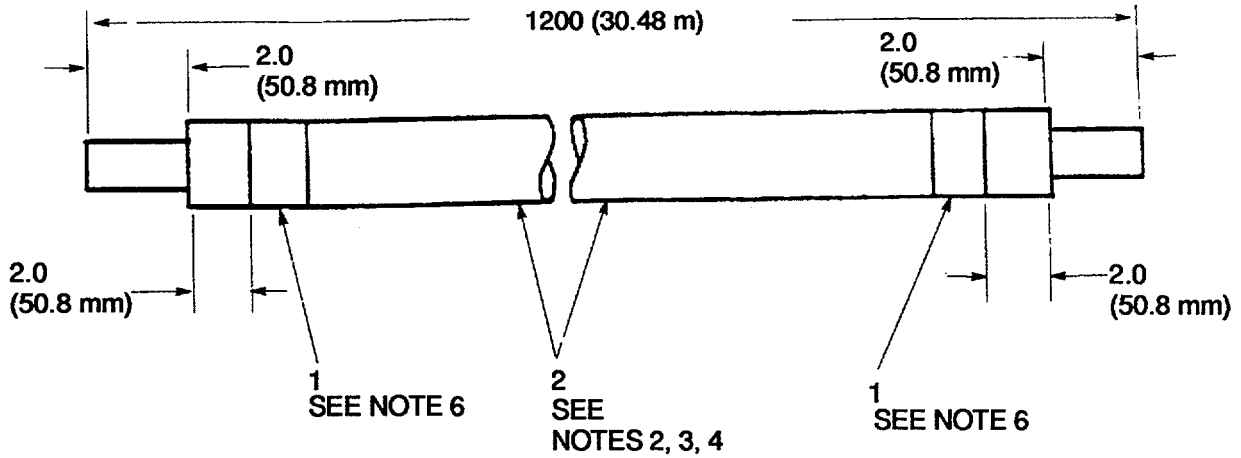

- 1. INSULATION SLEEVING
- 2. WIRE

**NOTES:**

1. ALL DIMENSIONS ARE IN INCHES, WITH METRIC EQUIVALENT IN PARENTHESES.
2. CUT AND REMOVE WIRE INSULATION FROM ENDS AS INDICATED.
3. CABLE WILL BE TYPE HDE OR HDF PER MIL-C-3432.
4. WIRE SIZES WILL BE AS FOLLOWS:

CONFIGURATION	SIZE
PHASE A	250 MCM
PHASE B	250 MCM
PHASE C	250 MCM
NEUTRAL	250 MCM
GROUND	NO. 1/0 AWG

5. GROUND CABLE SHALL BE A MINIMUM 4 FEET LONGER THAN CABLE ASSEMBLY LENGTH.
6. THE FIVE SINGLE-CONDUCTOR STRANDED CABLES THAT MAKE UP THE POWER INPUT CABLE KIT ARE BANDED FOR CORRECT PHASING AS FOLLOWS:

MARKING BAND INFORMATION	
BLACK	PHASE A
RED	PHASE B
BLUE OR ORANGE	PHASE C
WHITE	NEUTRAL
GREEN (If insulated)	GROUND

Figure G-3. Power Input Cable Assembly.

## APPENDIX H TORQUE LIMITS

**H.1 GENERAL.** This appendix provides general torque limits for screws used on the power distribution panel. The general torque limits given in this appendix shall be used when specific torque limits are not indicated in the maintenance procedure. These general torque limits cannot be applied to screws that retain rubber components. The rubber components will be damaged before the correct torque limit is reached. If a special torque limit is not given in the maintenance instructions, tighten the screw or nut until it touches the metal bracket, then tighten it one more turn.

**H.2 TORQUE LIMITS.** Table H-1 lists dry torque limits. Dry torque limits are used on screws that do not have lubricants applied to the threads.

Table H-1. Self-Locking Nut Breakaway Torque Values

**CAUTION**

The following torque values are derived from oil free, cadmium-plated threads.

Torque Limits (Recommended for Installation) (Bolts Loaded Primarily in Shear)			Maximum Allowable Tightening Torque Limits	
Tap Size	Tension type nuts MS20365 and AN310 (40,000 PSI in bolts)	Shear type nuts MS20364 and AN320 (24,000 PSI in bolts)	Nuts MS20365 and AN310 (90,000 PSI in bolts)	Nuts MS20364 and AN320 (54,000 PSI in bolts)
<b>FINE THREAD SERIES</b>				
8-36	12-15	7-9	20	12
10-32	20-25	12-15	40	25
1/4-28	50-70	30-40	100	60
5/16-24	100-140	60-85	225	140
3/8-24	160-190	95-110	390	240
7/16-20	450-500	270-300	840	500
1/2-20	480-690	290-410	1100	660
9/16-18	800-1000	480-600	1600	960
5/8-18	1100-1300	600-780	2400	1400
3/4-16	2300-2500	1300-1500	5000	3000
7/8-14	2500-3000	1500-1800	7000	4200
1-14	3700-5500	2200-3300*	10000	6000
1-1/8-12	5000-7000	3000-4200*	15000	9000
1-1/4-12	9000-11000	5400-6600*	25000	15000
<b>COARSE THREAD SERIES</b>				
8-32	12-15	7-9	20	12
1-24	20-25	12-15	35	12
1/4-20	40-50	25-30	75	45
5/16-18	80-90	48-55	160	100
1/8-16	150-185	95-100	275	170
7/16-14	235-255	140-155	475	280
1/2-13	400-480	240-290	880	520
9/16-12	500-700	300-420	1100	650
5/8-11	700-900	420-540	1500	900
3/4-10	1150-1600	700-950	2500	1500
7/8-9	2200-3000	1300-1800	4600	2700

\* Estimated corresponding values

The above torque values may be used for all cadmium-plated steel nuts of the fine or coarse thread series which have approximately equal number of threads and equal face bearing areas.

**GLOSSARY**

**SECTION I. ABBREVIATIONS**

ac .....	Alternating current
amp .....	Amperage
amp/ph.....	Amperage per phase
CB .....	Circuit breaker
cm.....	Centimeter(s)
CPC.....	Corrosion Prevention Control
CTA.....	Common table of allowances
DEPMEDS .....	Deployable medical system
DISE .....	Distribution illumination systems, electrical
EIR .....	Equipment improvement report
Hz .....	Hertz
ISO .....	Intentional standardization organization
kg.....	Kilogram(s)
Kw.....	kilowatt(s)
lb.....	Pound(s)
m .....	Meter(s)
Max.....	Maximum
mm .....	Millimeter(s)
MTOE .....	Modification table of organization and equipment
No .....	Number
NSN .....	National stock number
pf .....	Power factor
ph .....	Phase
PDISE.....	Power distribution and illumination system electrical
PMCS .....	Preventive maintenance checks and services
TB.....	Terminal bar
TEMPER.....	Tent, extendable, modular, personnel
TMDE .....	Test, measurement, and diagnostic equipment
V .....	Volts
Vac .....	Volts alternating current
W .....	Watts

**SECTION II. DEFINITION OF UNUSUAL TERMS**

Branch circuit	The portion of an electrical circuit that extends beyond the final current protection device (circuit breaker).
Continuity:	A continuous path for the flow of current in an electrical circuit.
Drop:	The terminating line of a T-connection on a branch circuit cable.
Neutral:	The electrical conductor of a 3-phase system with a potential such that the potential difference between the neutral and each phase is equal.
Phases:	The separate voltage waves in an alternating current supply.
Power factor:	The ratio of actual power to apparent power in an ac circuit.
Single-phase system:	An alternating-current circuit with one hot line and one neutral line.
Three-phase system:	An alternating-current with three hot lines and one neutral line.
Voltage loss:	The voltage drop across the electrical conductor.



## INDEX

**Subject, Page****A**

Abbreviations, List of, 1-2

Additional Authorization List, D-1  
 General, D-1  
 Introduction, D-1

Assembly and Preparation for Use, 2-7

Auxiliary Equipment, Operation of, 2-17

**B**

Basic Issue items (BII) Lists, Components of End  
 Items (COEI) and, C-1

**C**

Cabinet Assembly, 5-22

Cable Assemblies, 440, 5-25

Capabilities and Features, Equipment Characteristics, 1-3

Characteristics, Capabilities, and Features,  
 Equipment, 1-3

Check Unpacked Equipment, 42

Circuit Breaker, 60 and 100 Amp, 426

Circuit Breakers, 400-Amp, 5-6

Common Tools and Equipment, 4-1, 5-1

Components of End Item (COEI) and Basic Issue  
 Items (BII) List, Introduction, C-1

Components of End Item (COEI) and Basic Issue  
 Items (BII) Lists, C-1

Control, Quality Assurance/, 1-2

Controls, Indicators, and Connectors, Power  
 Distribution Panel, 2-1

Corrosion Prevention and Control (CPC), 1-2

**Subject, Page****D**

Data, Equipment, 1-5

Deadfront Panel Assembly, 5-4

Deadfront Panel Assembly and Top Cover Restraining  
 Cables, 4-19

Decals and Instruction Plates, 2-12

Description and Use of Operator's Controls and  
 Indicators, 2-1

Description of Major Components, Location and, 1-3

Destruction of Army Materiel to Prevent Enemy Use, 1-2

Direct Support Maintenance Instructions, 5-1

Direct Support Maintenance Procedures, 5-2  
 Cabinet Assembly, 5-22  
 Cable Assemblies, 5-25  
 Circuit Breakers, 400-Amp, 5-6  
 Deadfront Panel Assembly, 5-4  
 Electrical Leads, 5-18  
 Interior Panel Board Assembly, 5-8  
 MS Connectors, 5-20  
 Top Cover Assembly, 5-2

Direct Support Troubleshooting, 5-1

Dusty or Sandy Areas, Operation in, 2-18

**E**

Electrical Leads, 5-18

Emergency Procedures, 2-19

Equipment Characteristics, Capabilities, and Features,  
 1-3

Equipment Data, 1-5

Equipment Improvement Recommendations (EIR),  
 Reporting, 1-2

Equipment, Check Unpacked, 4-2

Expendable and Durable Items List, E-1  
 Scope, E-1

## INDEX (CONTINUED)

**Subject, Page**

Explanation of Columns in Tool and Test Equipment  
Requirements, B-3

Extreme Cold, Operation in, 2-17

Extreme Heat, Operation in, 2-18

**F**

Forms and Procedures, Maintenance, 1-2

Fuse Holder and Fuse, 4-32

**G**

General Information, 1-1

Glossary, Glossary-1

Abbreviations, Glossary-1

Definition of Unusual Terms, Glossary-2

**I**

Illustrated List of Manufactured Items, G-1

Introduction, G-1

Improvement Recommendations (EIR), Reporting  
Equipment, 1-2

Index, Symptom, 3-1, 4-4

Indicator Light Assembly and Indicator Light Bulb, 4-23

Information, General, 1-1

Instruction Plates, Decals and, 2-12

Instructions, Lubrication, 3-1

Instructions, Operating, 2-1

Instructions, PMCS, 4-2

Interior Panel Board Assembly, 5-8

Interlock Solenoid, 4-34

introduction, 1-1

**Subject, Page****L**

List of Abbreviations, 1 -2

Location and Description of Major Components, 1-3

Lubrication Instructions, 3-1

**M**

Maintenance Allocation Chart, B-1, B-4

General, B-1

Introduction, B-1

Maintenance Functions, B-1

Maintenance Checks and Services (PMCS), Operator  
Preventive, 2-4

Maintenance Checks and Services (PMCS), Unit  
Preventive, 4-2

Maintenance Forms and Procedures, 1-2

Maintenance Instructions, Direct Support, 5-1

Maintenance Instructions, Operator, 3-1

Maintenance Instructions, Unit, 41

Maintenance Procedures, 3-3

General, 3-3

Inspection, 3-3

Repair, 3-3

Maintenance Procedures, Direct Support, 5-2

Maintenance Procedures, Unit, 4-17

Movement, Preparation for, 2-17

MS Connectors, 4-36, 5-20

**O**

Operating Instructions, 2-1

Operating Procedures, 2-11

Operation in Dusty or Sandy Areas, 2-18

Operation in Extreme Cold, 2-17

Operation in Extreme Heat, 2-18

Operation in Rainy or Humid Conditions, 2-18

Operation in Saltwater Areas, 2-18

## INDEX (CONTINUED)

**Subject, Page**

Operation of Auxiliary Equipment, 2-17  
 Operation Under Unusual Conditions, 2-17  
 Operation Under Usual Conditions, 2-7  
 Operation, Principles of, 1-6  
 Operator Maintenance Instructions, 3-1  
 Operator PMCS Procedures, 2-4  
 Operator Preventive Maintenance Checks and  
     Services (PMCS), 2-4  
     Introduction, 2-4  
 Operator Troubleshooting, 3-2  
 Operator, Unit, and Direct Support Maintenance  
     Repair Parts and Special Tools List, F-1  
     General, F-1  
     Introduction, F-1  
 Operator's Controls and Indicators, Description and  
     Use of, 2-1

**p**

Parts, Repair, 4-1, 5-1  
 PMCS Instructions, 4-2  
 PMCS Procedures, Operator, 2-4  
 Power Distribution Panel Controls, Indicators, and  
     Connectors, 2-1  
 Preparation for Movement, 2-17  
 Preparation For Storage or Shipment, 4-42  
 Preparation for Use, Assembly and, 2-7  
 Prevent Enemy Use, Destruction of Army Materiel, 1-2  
 Prevention and Control (CPC), Corrosion, 1-2  
 Preventive Maintenance Checks and Services  
     (PMCS), Unit, 4-2  
 Principles of Operation, 1-6  
 Principles of Operation, Technical, 1-6  
 Procedures, Emergency, 2-19  
 Procedures, Maintenance, 3-3

**Subject, Page**

Procedures, Operating, 2-11  
 Procedures, Troubleshooting, 3-1

**Q**

Quality Assurance/Quality Control (QA/QC), 1-2

**R**

Rainy or Humid Conditions, Operation in, 2-18  
 Receipt of Material, Service Upon, 41  
 Receipt, Service Upon, 4-1  
 References, A-1  
     Field Manuals, A-1  
     Forms, A-1  
     Miscellaneous Publications, A-2  
     Scope, A-1  
     Technical Manuals, A-1  
 Repair Parts, 41, 5-1  
 Repair Parts; Tool; Special Tools; Test, Measurement,  
     and Diagnostic Equipment (TMDE); and Support  
     Equipment, 5-1  
 Repair Parts; Tools, Special Tools; Test, Measurement,  
     and Diagnostic Equipment (TMDE); and Support  
     Equipment, Introduction, 4-1  
 Repair Parts; Tools; Special Tools; Test, Measurement,  
     and Diagnostic Equipment (TMDE); and Support  
     Equipment, 4-1  
     Introduction, 5-1  
 Reporting Equipment Improvement Recommendations  
     (EIR), 1-2

**S**

Saltwater Areas, Operation in, 2-18  
 Scope, 1-2  
 Scope, General Information, 1-2  
 Service Upon Receipt, 41  
 Service Upon Receipt of Material, 41  
 Special Tools, 4-1, 5-1

## INDEX (CONTINUED)

**Subject, Page**

Special Tools, TMDE, and Support Equipment, 4-1,  
5-1  
Storage or Shipment, Preparation For, 4-42  
Subpanel, 4-21  
Support Equipment, 4-1, 5-1  
Support Equipment, Special Tools, TMDE, and, 5-1  
Symptom Index, 3-1, 4-4

**T**

Technical Principles of Operation, 1-6  
Terminal Blocks, 4-30  
Test, Measurement, and Diagnostic Equipment  
(TMDE), 4-1, 5-1  
Tools and Equipment, Common, 4-1, 5-1  
Tools; Special Tools; Test, Measurement, and  
Diagnostic Equipment (TMDE); and Support  
Equipment, Repair Parts, 4-1  
Top Cover Assembly, 4-17, 5-2  
Torque Limits, H-1  
Troubleshooting Procedures, 3-1  
Introduction, 3-1  
Troubleshooting, Direct Support, 5-1

**Subject, Page**

Troubleshooting, Operator, 3-2  
Troubleshooting, Unit, 44

**U**

Unit Maintenance Instructions, 4-1  
Unit Maintenance Procedures, 4-17  
Cable Assemblies, 440  
Circuit Breaker, 60 and 100 Amp, 426  
Deadfront Panel Assembly and Top Cover  
Restraining Cables, 4-19  
Fuse Holder and Fuse, 4-32  
Indicator Light Assembly and Indicator Light Bulb,  
4-23  
Interlock Solenoid, 4-34  
MS Connectors, 4-36  
Subpanel, 4-21  
Terminal Blocks, 4-30  
Top Cover Assembly, 4-17  
Unit Preventive Maintenance Checks and Services  
(PMCS), 4-2  
Introduction, 4-2  
Unit Maintenance Instructions, 4-2  
Unit Troubleshooting, 4-4  
Introduction, 4-4  
Unusual Conditions, Operation Under, 2-17  
Use of Operator's Controls and Indicators, Description  
and, 2-1  
Usual Conditions, Operation Under, 2-7

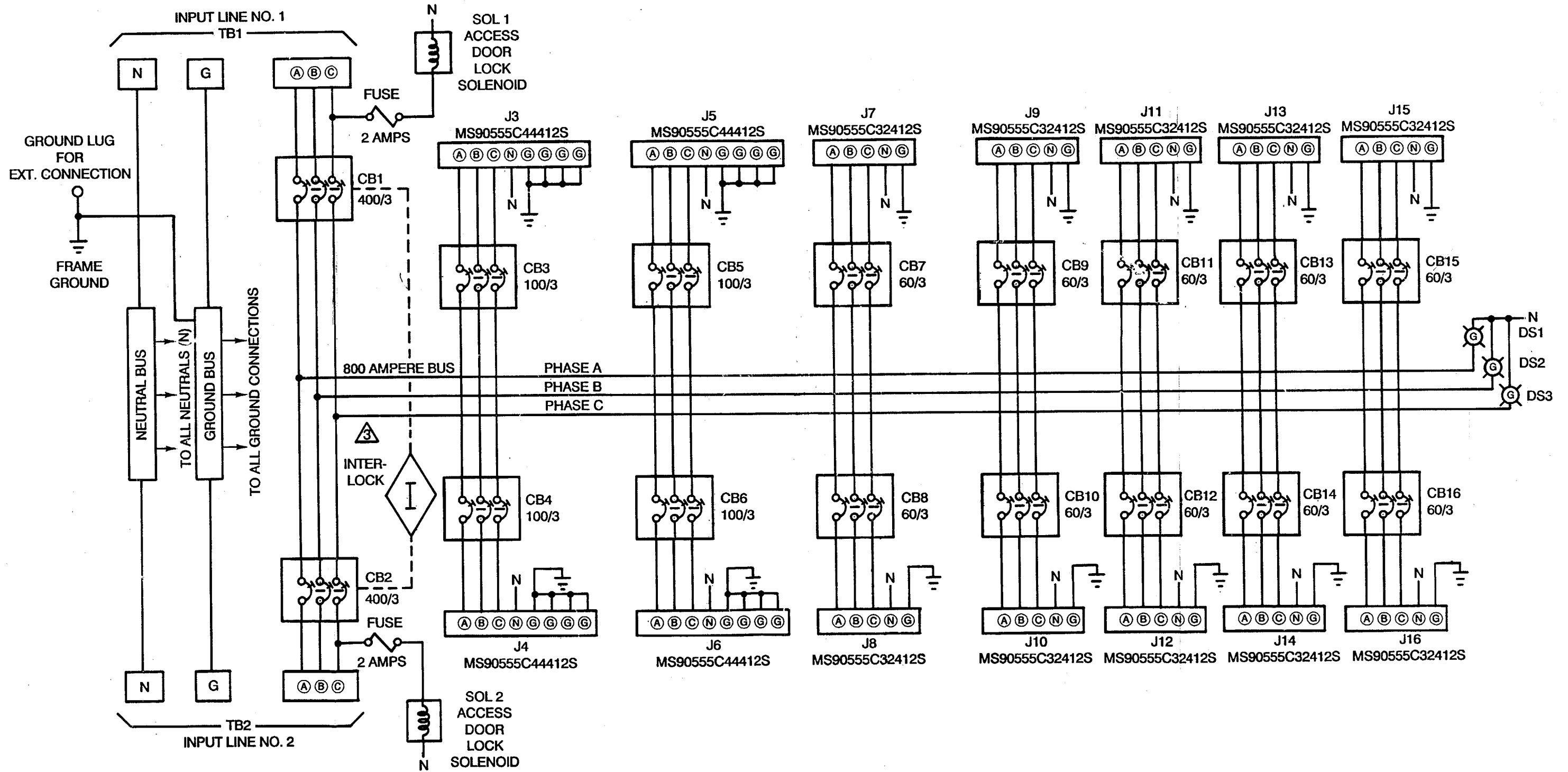

Figure FO-1. Power Distribution Panel Schematic Diagram

FP-1/(FP-2 blank)

By Order of the Secretary of the Army:

DENNIS J. REIMER  
*General, United States Army*  
*Chief of Staff*

Official:

JOEL B. HUDSON  
*Acting Administrative Assistant to the*  
*Secretary of the Army*

01606

DISTRIBUTION:

To be distributed in accordance with DA Form 12-25-E, block no. 6350, requirements for TM 9-6150-228-13&P.

## These are the instructions for sending an electronic 2028

The following format must be used if submitting an electronic 2028. The subject line must be exactly the same, and all fields must be included; however only the following fields are mandatory: 1, 3, 4, 5, 6, 7, 8, 9, 10, 13, 15, 16, 17, and 27.

From: "Whomever"<whomever@avma27.army.mil>

To: mpmt%avma28.army.mil@st-louis-emh.army.mil

Subj: DA Form 2028

1. **From:** Joe Smith
2. **Unit:** home
3. **Address:** 4300 Park
4. **City:** Hometown
5. **St:** MO
6. **Zip:** 77777
7. **Date Sent:** 19-OCT-93
8. **Pub no:** 55-2840-229-23
9. **Pub Title:** TM
10. **Publication Date:** 04-JUL-85
11. **Change Number:** 7
12. **Submitter Rank:** MSG
13. **Submitter FName:** Joe
14. **Submitter MName:** T
15. **Submitter LName:** Smith
16. **Submitter Phone:** 123-123-1234
17. **Problem:** 1
18. **Page:** 2
19. **Paragraph:** 3
20. **Line:** 4
21. **NSN:** 5
22. **Reference:** 6
23. **Figure:** 7
24. **Table:** 8
25. **Item:** 9
26. **Total:** 123
27. **Text:**

This is the text for the problem below line 27.

## THE METRIC SYSTEM AND EQUIVALENTS

### LINEAR MEASURE

1 Centimeter = 10 Millimeters = 0.01 Meters = 0.3937 Inches  
 1 Meter = 100 Centimeters . 1000 Millimeters ~ 39.37 Inches  
 1 Kilometer = 1000 Meters = 0.621 Miles

### WEIGHTS

1 Gram . 0.001 Kilograms = 1000 Milligrams = 0.035 Ounces  
 1 Kilogram . 1000 Grams - 2.2 Lb  
 1 Metric Ton ~ 1000 Kilograms ~ 1 Megagram = 1.1 Short Tons

### LIQUID MEASURE

1 Milliliter = 0.001 Liters . 0.0338 Fluid Ounces  
 1 Liter = 1000 Milliliters-33.82 Fluid Ounces

### SQUARE MEASURE

1 Sq Centimeter = 100 Sq Millimeters = 0.155 Sq Inches  
 1 Sq Meter= 10,000 Sq Centimeters = 10.76 Sq Feet  
 1 Sq Kilometer = 1,000,000 Sq Meters = 0.0386 Sq Miles

### CUBIC MEASURE

1 Cu Centimeter = 1000 Cu Millimeters = 0.06 Cu Inches  
 1 Cu Meter = 1,000,000 Cu Centimeters = 35.31 Cu Feet

### TEMPERATURE

$5/9(F - 32) = C$   
 212 Fahrenheit is equivalent to 100 Celsius  
 90 Fahrenheit is equivalent to 32.2 Celsius  
 32 Fahrenheit is equivalent to 0 Celsius  
 $9/5 C + 32.F$

### APPROXIMATE CONVERSION FACTORS

TO CHANGE	TO	MULTIPLY BY
Inches	Centimeters	2.540
Feet	Meters	0.305
Yards	Meters	0.914
Miles	Kilometers	1.609
Square Inches	Square Centimeters	6.451
Square Feet	Square Meters	0.093
Square Yards	Square Meters	0.836
Square Miles	Square Kilometers	2.590
Acres	Square Hectometers	0.405
Cubic Feet	Cubic Meters	0.028
Cubic Yards	Cubic Meters	0.765
Fluid Ounces	Milliliters	29.573
Pints	Liters	0.473
Quarts	Liters	0.946
Gallons	Liters	3.785
Ounces	Grams	28.349
Pounds	Kilograms	0.454
Short Tons	Metric Tons	0.907
Pound-Feet	Newton-Meters	1.358
Pounds Per Square Inch	Kilopascals	6.895
Miles Per Gallon	Kilometers Per Liter	0.425
Miles Per Hour	Kilometers Per Hour	1.609

TO CHANGE	TO	MULTIPLY BY
Centimeters	Inches	0.394
Meters	Feet	3.280
Kilometers	Miles	0.621
Square Centimeters	Square Inches	0.155
Square Meters	Square Feet	10.764
Square Meters	Square Yards	1.196
Square Kilometers	Square Miles	0.386
Square Hectometers.	Acres	2.471
Cubic Meters	Cubic Foot	35.315
Cubic Meters	Cubic Yards	1.308
Milliliters	Fluid Ounces	0.034
Liters	Pints	2.113
Liters	Quarts	1.057
Liters	Gallons	0.264
Grams	Ounces	0.035
Kilograms	Pounds	2.205
Metric Tons	Short Tons	1.102
Newton-Meters	Pound-Feet	0.738
Kilopascals	Pounds per Square Inch	0.145
Kilometers per Liter	Miles per Gallon	2.354
Kilometers per Hour	Miles per Hour	0.621



RECOMMENDED CHANGES TO EQUIPMENT TECHNICAL PUBLICATIONS



*THEN...JOT DOWN THE  
DOPE ABOUT IT ON THIS FORM.  
CAREFULLY TEAR IT OUT, FOLD IT  
AND DROP IT IN THE MAIL.*

# SOMETHING WRONG WITH PUBLICATION

FROM: (PRINT YOUR UNIT'S COMPLETE ADDRESS)

DATE SENT

PUBLICATION NUMBER

PUBLICATION DATE

PUBLICATION TITLE

BE EXACT PIN-POINT WHERE IT IS

PAGE  
NO.

PARA-  
GRAPH

FIGURE  
NO.

TABLE  
NO.

IN THIS SPACE, TELL WHAT IS WRONG  
AND WHAT SHOULD BE DONE ABOUT IT.

TEAR ALONG PERFORATED LINE

PRINTED NAME, GRADE OR TITLE AND TELEPHONE NUMBER

SIGN HERE

DA FORM 2028-2  
1 JUL 79

PREVIOUS EDITIONS  
ARE OBSOLETE.

P.S.--IF YOUR OUTFIT WANTS TO KNOW ABOUT YOUR  
RECOMMENDATION MAKE A CARBON COPY OF THIS  
AND GIVE IT TO YOUR HEADQUARTERS.

**PIN: 074606-000**